



Fire & Safety

Integrated systems for fire detection and building control





No matter how advanced our technology might be, it is necessary to remember that devices are the tools that achieve the aim of protection.

What is really needed is conscious education in building safety.

Index

Company profile	4
Cloud and App	14
Addressed control panels	17
Previdia series	20
Previdia Compact	22
Previdia Max	28
Previdia UltraVox	40
Inim Cloud Fire	56
Inim Fire App	58
IASS and IAC	60
Previdia Studio	61
SmartLoop	62
SmartLight	70
Analogue-addressable devices	75
Addressable detectors	
Addressable modules	
Addressable call points	
Addressable alarm indicators	
Wireless devices	97
Speakers	105
Conventional control panels	117
Conventional devices	123
Conventional detectors	
Conventional call points	
Conventional alarm indicators	
F-COM universal communicator	136
Aspirating smoke detectors	139
Special detection	147
GAS detection	159
ATEX devices	171
Marine devices	176
Completion and system test	179
Fire suppression accessory items	
Power supply stations	
Hold open electromagnets	
Detectors test	
Accessories	
Emergency lighting	195
BMS software	205





2006

We break into the market by introducing **SmartLoop control panels**, a product with cutting-edge technology such as architecture and distributed intelligence.



2015

At a distance of 10 years we are once again revolutionizing the market.

Previdia Max is the first in the market sector to use LCD screens and introduce concepts such as video verification, on-screen graphic maps and modular architecture.



2007

The introduced technologies are condensed in a compact control panel, to give birth to the **SmartLight**



The **SmartLine** is delivered, a conventional control panel which in terms of value for money and flexibility still remains unbeaten and unbeatable in the sector.



2010

The addition of **Enea and Iris** detectors to our product park, which for the first time introduce the concepts of **VERSA++** and **OpenLoop** into the fire-fighting market.

New production plant of over 13,000 m²





The security of having Inim

A history of over 15 years dedicated to protection

A 100% Italian company in continuous evolution, since 2005 we have established ourselves on the world market of fire detection with products that, thanks to quality, technologies and extensive lineup, are unrivaled on the market.

The commitment of our R&D departments to the development of new solutions along with investments in highly automated production lines have propelled us towards a cutting-edge park of products.

Today we boast the unequalled ability to fulfill sector needs with products that are unique on the market for their ease of installation, use and maintenance.



2018

Previdia Compact: all the power of Previdia Max is condensed and made compact in the flexible and agile Previdia Compact.



2022

The ultimate revolution.
Previdia UltraVox: the only system in the European panorama that perfectly integrates fire detection and voice evacuation with endless possibilities.



Implementation of a robotic line for detector production



2019

Inim Fire Cloud: the revolutionary concept of the Cloud applied to fire detection systems introduces a new standard for the remote monitoring, management and maintenance of fire systems.



Inim Fire App: all the power of Inim Fire Cloud comes to your fingertips on smartphones, a new record set by Inim.



2023

FA100
New aspirating smoke detector, based on innovative dual-light technology.



Globally renowned

Products guaranteed by every certification body

Our continuous commitment to the innovation of the fire detection sector and investments over the years, aimed at developing ever new technologies, allow us today to boast national and international certifications.

The certifications that we hold are not only a testimony of product validity, but also of the success achieved by our products on a global level.





We sit at the table of the big

We take part in technical round tables to define new regulations for the sector.

Thanks to in-depth sector expertise and the advanced technologies which constantly revolutionize the national and international market, we have the privilege of sitting at numerous technical round tables inside regulatory bodies and trade associations.

A constant commitment that allows us to actively participate in the development of the reference legislation by making available our expertise and professionalism.





Production process
subjected to certification



Over 200,000
components per
hour



Highly automated
production line



Testing and calibration of
100% of production

1 on 10 thousand

One piece in 10 thousand
rejected per day



Every board we produce is subjected to in-circuit testing by means of sophisticated automated lines.

During the process the parameters of each individual component are measured, the continuity and shorts of each trace are checked, the software embedded in the microcontrollers on the boards is transferred and an automatic functional test is performed which verifies each function of the product.

Every single step is recorded in the production database on which statistical checks are carried out capable of predicting any qualitative drifts.

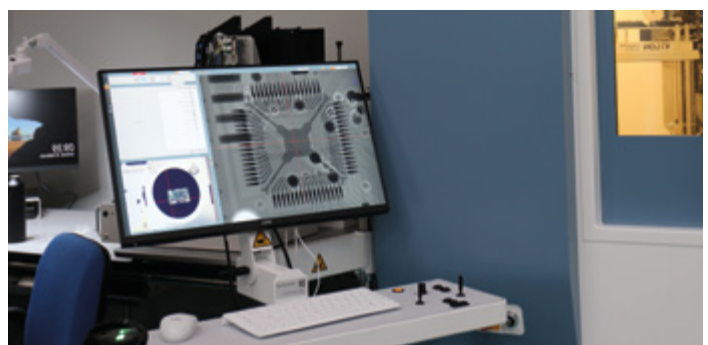
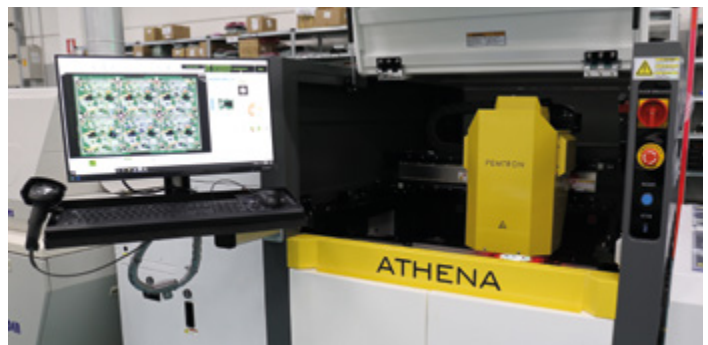



Made in Italy Made in Inim



Watch
video

100% Italian quality

The production process is based on a highly automated SMT assembly department where lines that operate in parallel guarantee the continuous flow of boards required by the subsequent departments.

The SMT assembly lines, with a capacity of about 60'000 components per hour each, use automated warehouses for component storage, controlled reflow ovens and optical inspection lines for checking the assembled boards.

The detector assembly line is the flagship of the company. Made according to the industry 4.0 directive, it automates the processes for a product of superior quality and assurance.

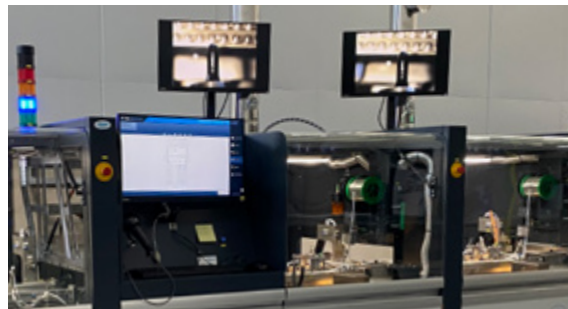
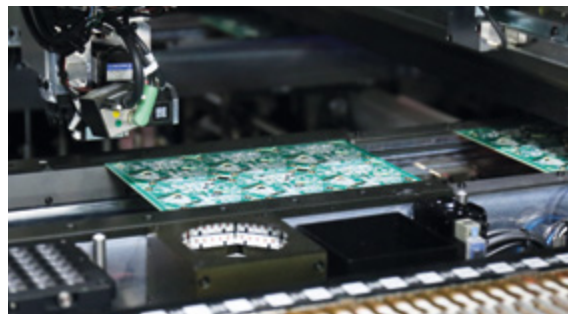

- **Research & Development**
- **Quality Check of raw materials**
- **SMT assembly**
- **Optical inspection**
- **Selective welder**
- **ATE testing**
- **Conformal Coating**
- **Assembly**
- **Calibration and finished product test**
- **Burn in**
- **Lot validation**
- **Dispatch**



**We start off
from Italy.
We arrive in
the world.**

**Over one million
structures in the
world use Inim
products**

Inim participates as a protagonist in major international events for the sector such as trade fairs, forums and workshops.

Our constant presence has made our fire detection products among the best known and most appreciated, both in the Italian market and in the various world markets.

To date, our products made entirely in Italy, reach the four corners of the globe for use in European, Middle Eastern, African and Latin American projects.

This page shows just some of the ambitious structures that can boast the use of Inim products.

Coimbra Hospital

Portugal



Confederación Sudamericana de Fútbol

Paraguay

Turquesa hotel

Tenerife





Silver Tower

Brussels



Nordre Jarlsberg Brygge

Norway

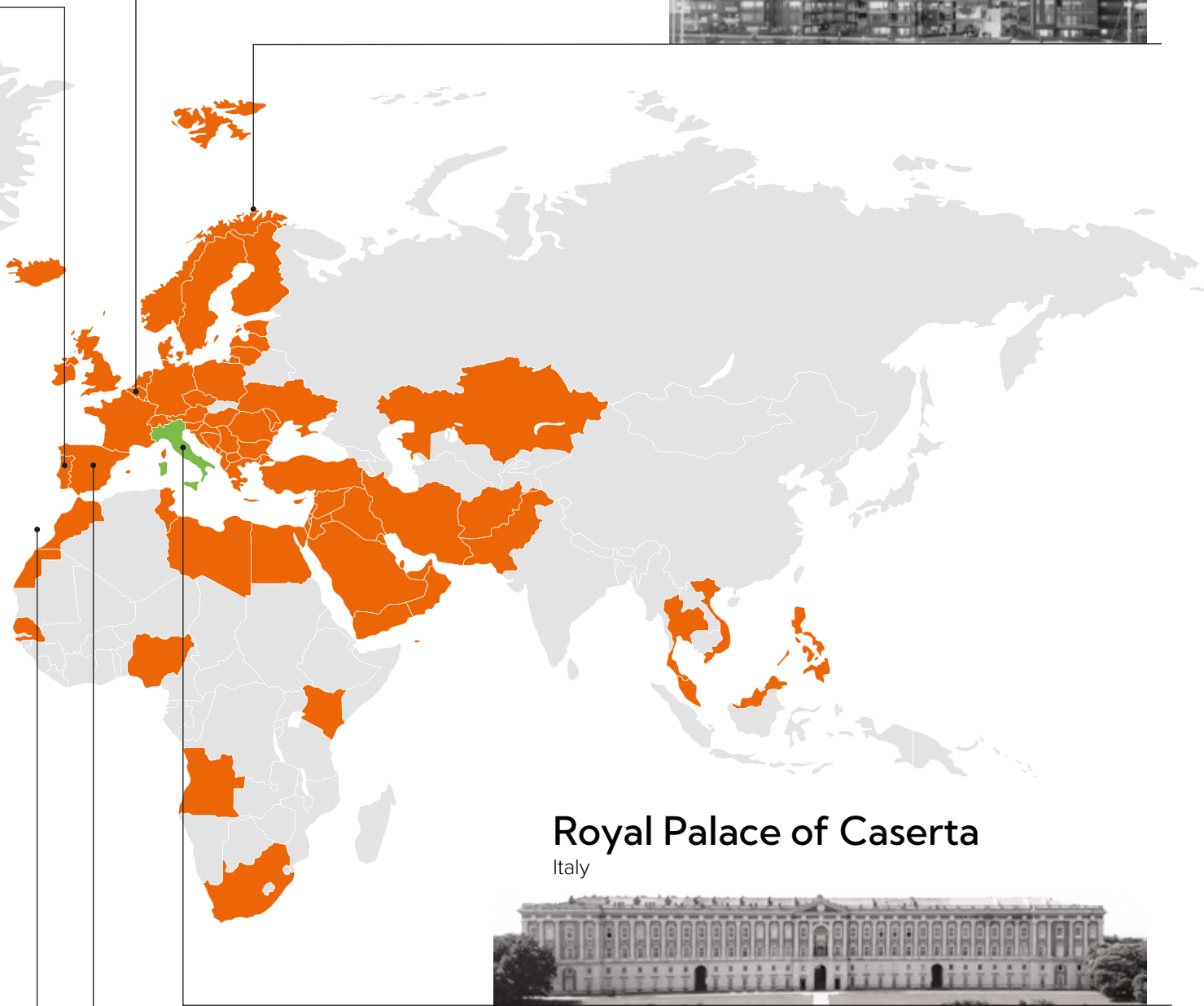

Royal Palace of Caserta

Italy



Infanta Sofía Hospital

Madrid





We write the technology of the industry

In-house cutting-edge R&D department

We hold the intellectual property of every single product manufactured, and it is thanks to this expertise and technical knowledge that we are always able to respond effectively and in advance to market challenges.



Our laboratories are equipped with apparatus capable of taking climatic measurements, acoustic measurements in an anechoic chamber, intensity measurements of luminous fluxes and many other tests to ensure absolute quality products.

Within our facilities we are able to perform response tests on smoke and temperature detectors in reference to European and international standards, such as the test in the Fire Test Room, this gives us constant control over the development and quality of our detectors.

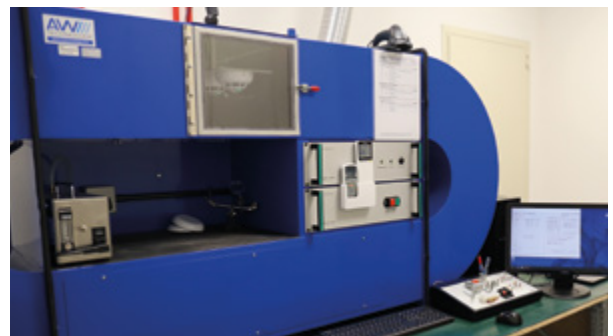
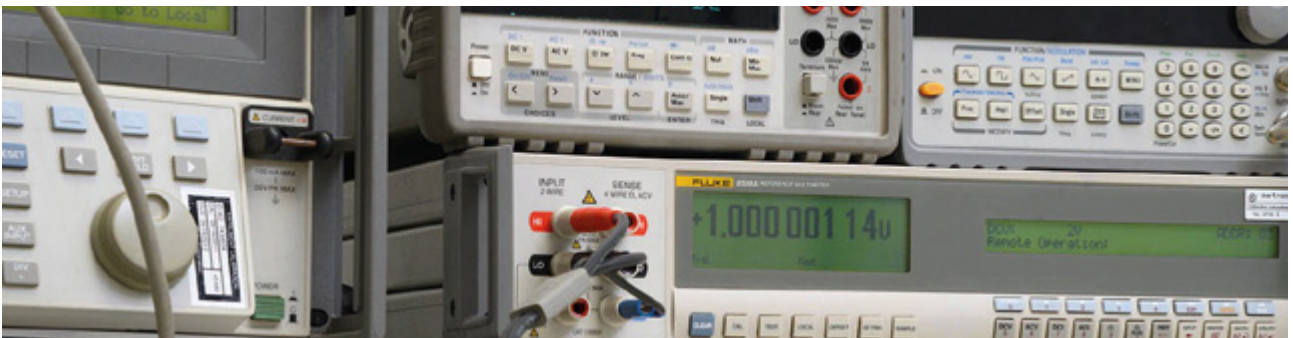

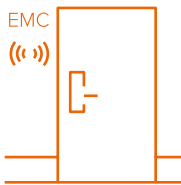
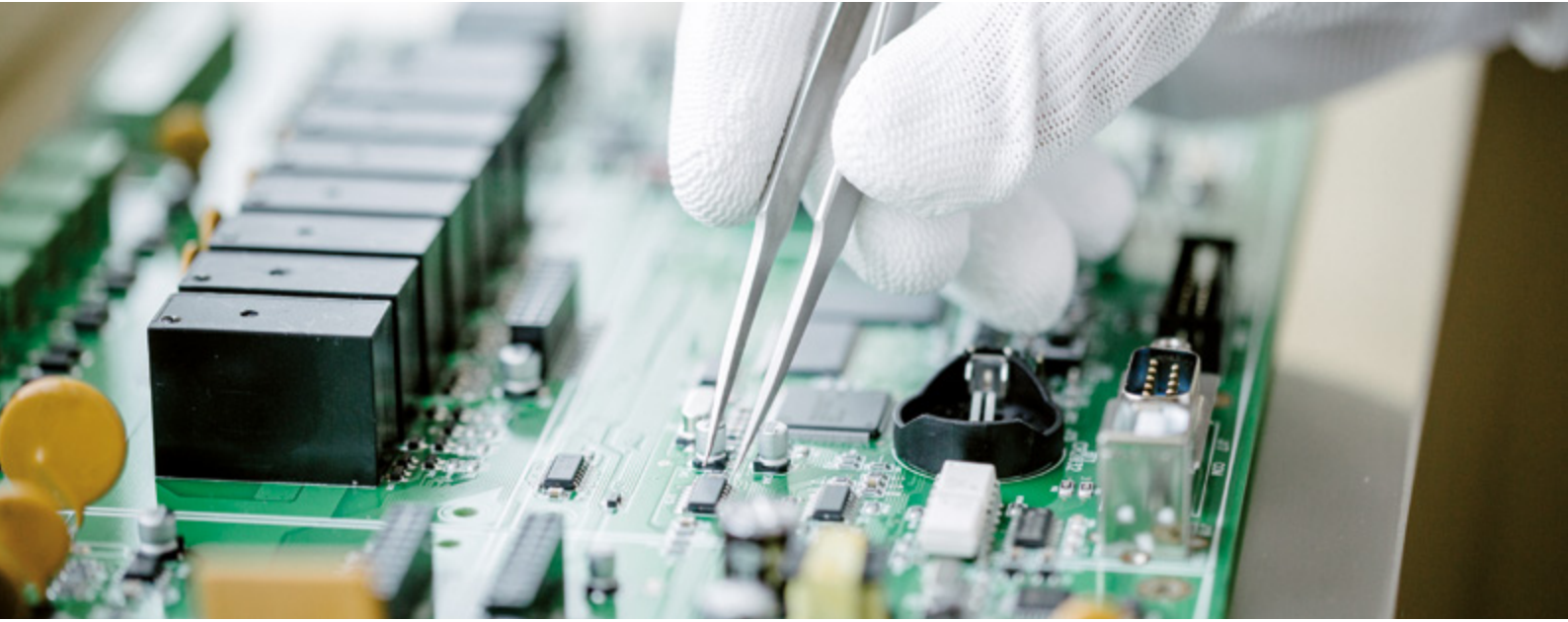

We are equipped with a sophisticated EMC laboratory that few companies can boast. The desire to introduce such a sophisticated control system inside Inim bears witness to our pursuit of absolute quality and our passion for technology. Thanks to the anechoic chamber we can carry out:

- Measurements of electromagnetic emission, to verify compliance with the radiated field limits
- Measurements of radiated susceptibility during which the equipment is subjected to a strong electric field in order to verify its robustness
- Measurements of emissions and immunity conducted on cables and interconnection points of the devices
- Measurements of immunity to high energy disturbance (Burst, Surge, etc.) that can couple on cables or on product casings

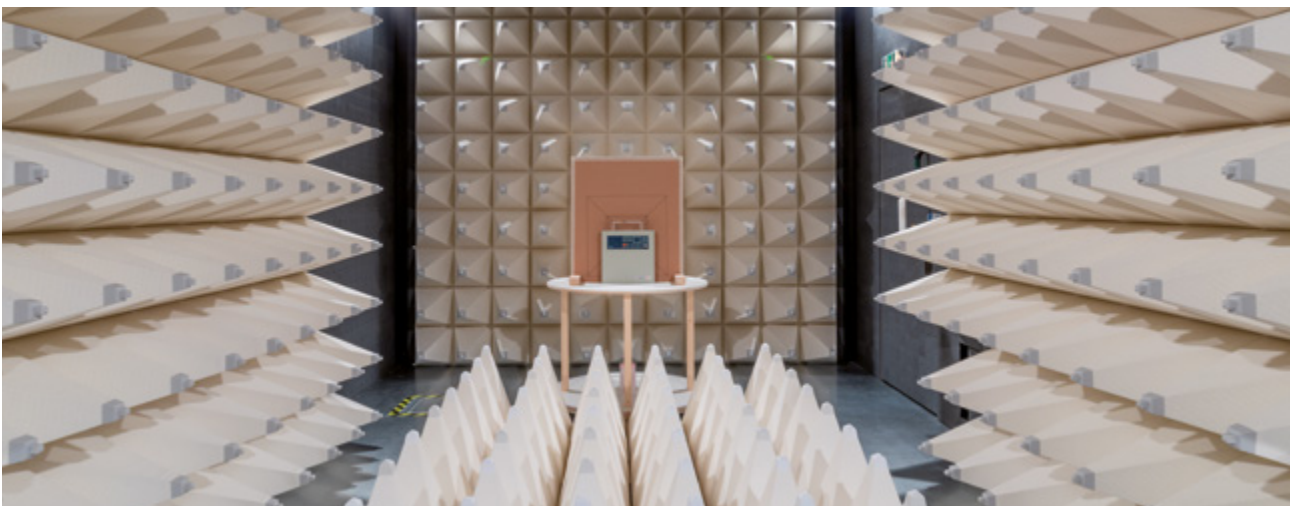



Cloud and App Always the forerunners

A universe of functions to improve the job of every professional

Our company was among the first to create a Cloud infrastructure for the monitoring, control and management of fire detection systems both remotely and via App.

The Inim Cloud infrastructure immediately proved to be a crucial tool for punctual and effective management and maintenance, capable of giving our systems the credibility and reliability necessary to be used in ambitious national and international projects.



Remote monitoring and control



Installation registry and maintenance



System diagnostics



Interactive graphic maps



Video verification

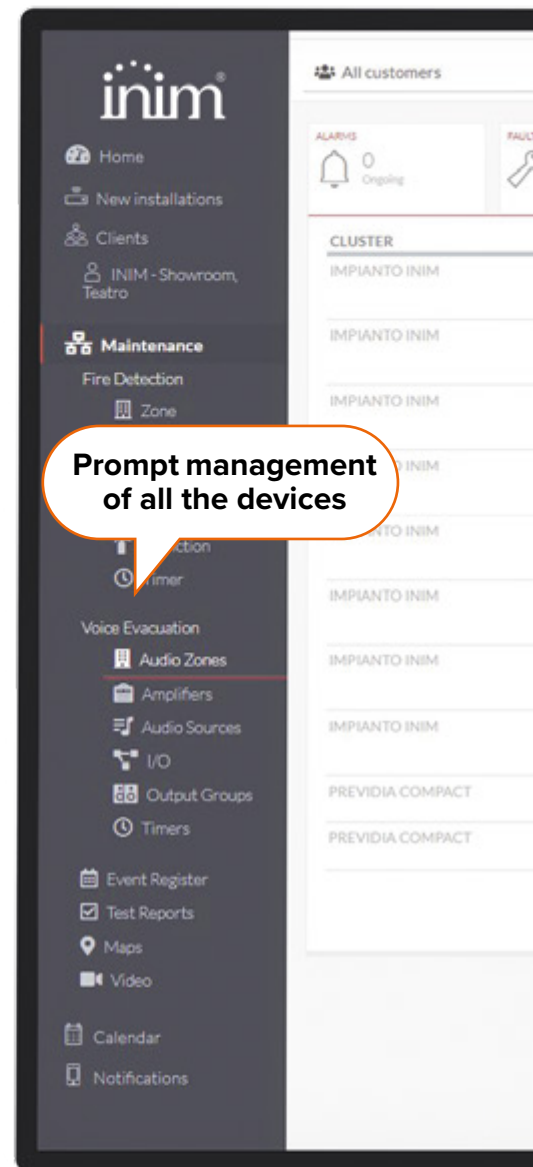

Watch the Inim Fire Cloud video



Watch the Inim Fire App video



Synthetic view of the status of installations

The dashboard includes several status indicators: 11 Ongoing, 13 Disabled, 0 Ongoing Early Warnings, 0 Ongoing Monitor, 0 Ongoing Supervisory, 0 Ongoing Test, 0 Ongoing Gas, and 0 Ongoing Voice Evac.

PANEL	TIME	DATE	DESCRIPTION	
MAX ReD FIRE	11:17 AM	10/21/2022	ESCLUSIONE	LOOP FA100 Locali Tecnici
MAX ReD FIRE	11:17 AM	10/21/2022	ESCLUSIONE	ASP. CONTROSOFFITTI LOOP FA100 Planerotolli
MAX ReD FIRE	11:17 AM	10/21/2022	ESCLUSIONE	ASP. CONTROSOFFITTI Zona Zona 2
MAX ReD FIRE	11:17 AM	10/21/2022	ESCLUSIONE	ASPIRAZIONE CAVEDI Zona Zona 1
MAX PRODUZIONE	11:16 AM	10/21/2022	ESCLUSIONE	REPARTO ASSEMBLAGGI Loop4 Asp.Locale Tecnico
MAX PRODUZIONE	11:16 AM	10/21/2022	ESCLUSIONE	REPARTO ASSEMBLAGGI Loop4 Aspirazione Produzi
MAX PRODUZIONE	11:16 AM	10/21/2022	ESCLUSIONE	MAGAZZINO Loop4 Aspirazione Mag C.1
MAX PRODUZIONE	11:16 AM	10/21/2022	ESCLUSIONE	MAGAZZINO Loop4 Aspirazione Mag C.2
COMPACT ATMEL	2:18 PM	10/19/2022	BATTERIA ASSENTE	Scheda PSU 1 Scheda PSU 1
COMPACT ATMEL	2:18 PM	10/19/2022	GUASTO GENERICO	Comunicatore Guasto PSTN

Counters of the non-managed events

Copyright © 2022 INIM Electronics S.r.l. Unipersonale All rights reserved. [Privacy policy](#) | [Terms & Conditions](#) | [Cookie policy](#)

Graphic maps

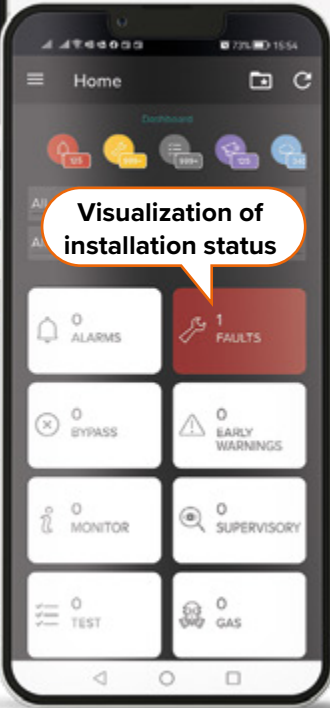

Visualization of installation status



Walk test



Addressable fire control panels

The technological heart of each installation

Fire-fighting installations using an addressable system require the installation of detection devices on a connection and power line set up as a ring, the loop, beginning and ending on the control panel itself. Each loop manages up to 240 elements connected and identified by the assignment of progressive identification numbers.

The first advantage of this configuration is the high level of control and reliability: thanks to the process of addressing detectors it is possible to locate danger precisely in the event of an alarm. Moreover, in the event of an interruption or malfunction on the connection line the control panel is able to maintain complete system functionality.

Addressable analogue detection systems comprise a control panel, the heart of the system, smoke and gas detectors, alarm call points, sounders and modules for interacting with the various systems of the building.



Inim systems speed up system commissioning and maintenance



They are highly interactive and provide detailed information on every single point



They are highly intuitive thanks to the graphic display with maps and video verification



Multiprocessor architecture, redundant hardware for greater reliability





PREVIDIA SERIES FUNCTIONS

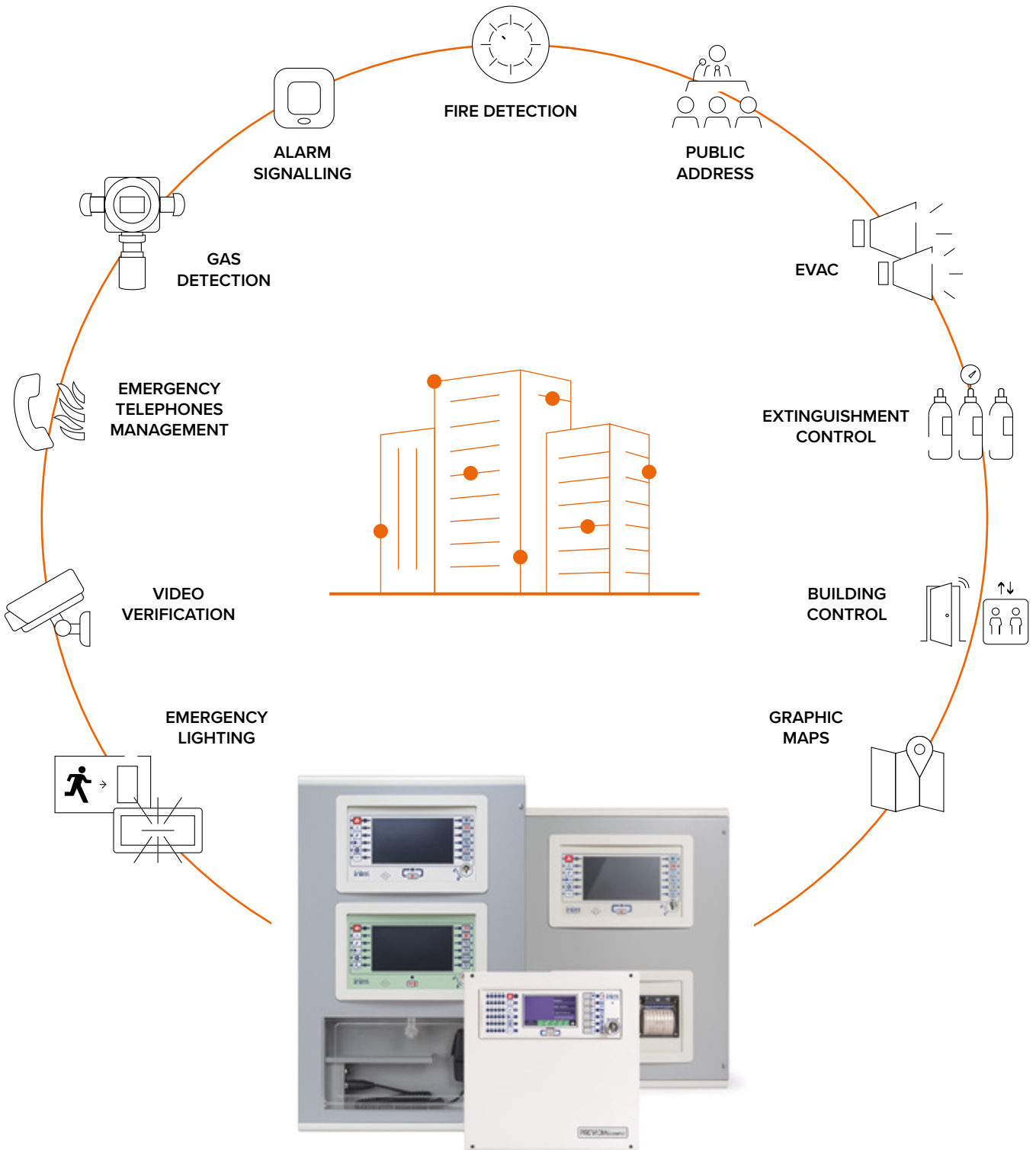



Previdia control panel diagram

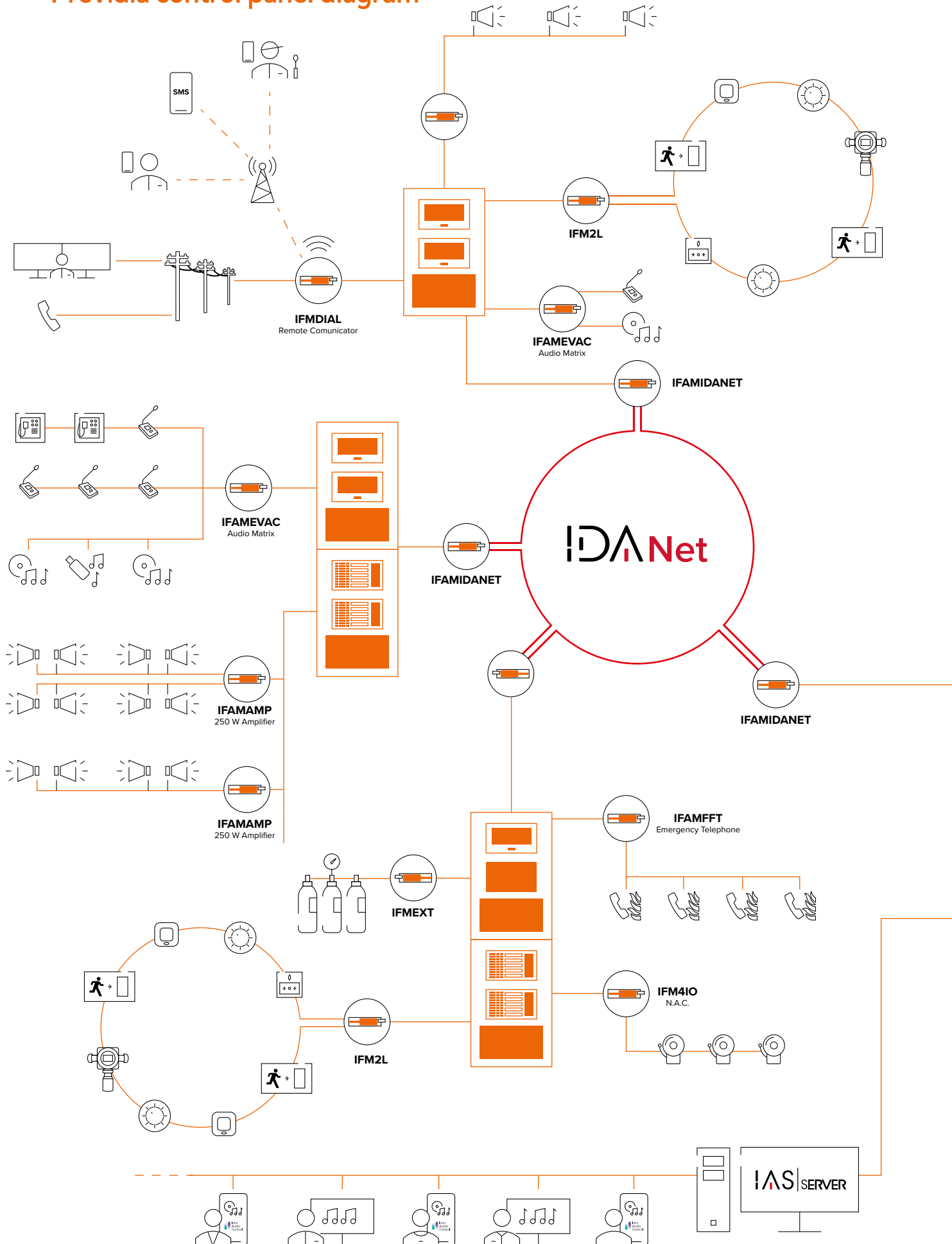

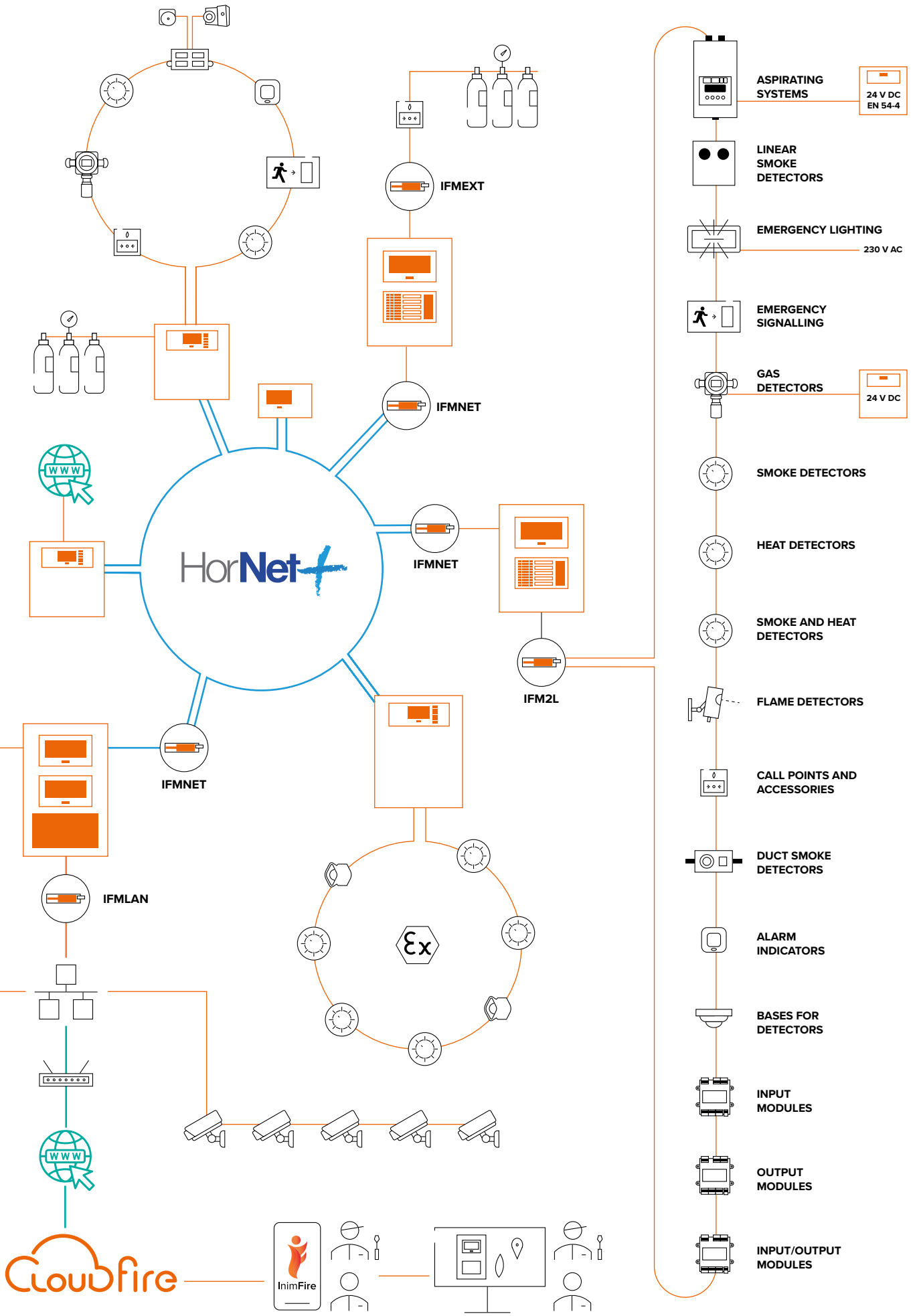



Previdia Compact

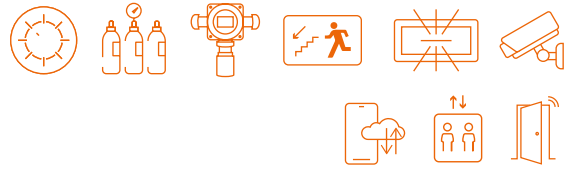

Compact, intuitive, instant. Perfect for systems of up to 480 points

The analogue-addressable control panels from the Previdia Compact series represent the ideal solution for small to medium installations, combining inside a compact cabinet the innovative features of the Previdia system and a unique ease of use. Programming from the display through a clear and intuitive user interface allows you to minimize the system activation and maintenance times.



TECHNICAL SPECIFICATIONS

Power supply voltage:	230 V~ (-15% / +10%) 50/60 Hz	Version dimensions (S):	322 x 324 x 86 mm
Maximum absorption from the 230V line:	0.5 A (S); 1 A (L)	Version dimensions (L):	497 x 380 x 97 mm
Nominal output voltage:	27.6 V	Weight (S):	3.3 Kg
Maximum output current:	1.5 A (S); 4 A (L)	Weight (L):	6.1 Kg
Battery specifications:	2 x 12 V, 7 Ah (S); 2 x 12 V, 17 Ah (L)		
Operating temperature:	-5° ... 40° C		
Enclosure protection grade:	IP30		



See the
online
section



EN54 certified

Previdia Compact has obtained all the applicable EN54 certifications:

- EN54-2: Control panel and signalling devices;
- EN54-4: Power supply units;
- EN54-21: Alarm transmission and remote fault signalling and warning equipment;
- EN12094-1: Gas extinguishing system components. Automatic electrical command and shutdown and delay management devices
- EN54-13: Compatibility of system components.

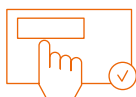

Simple installation

Thanks to the 4.3" graphic colour touch-screen, the configuration and maintenance of the system is simple and fast. The intuitive interface and the complete programmability provide a tool that is unmatched by other control panels available on the market.



Intuitive

Thanks to innovative concepts such as interactive graphic maps and video verification, it allows for fast and effective emergency management.

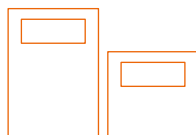

Flexible

It is available in two sizes to suit different installation needs:

- small, with 1.5A power-supply and 7Ah batteries
- large, with 4A power-supply and 17Ah batteries

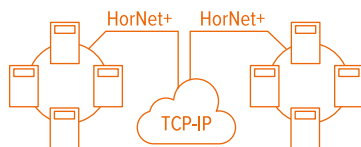

Networkable

The control panels can be networked together thanks to the HORNET+ system (up to a max of 50 nodes) or with Previdia Max and Previdia Ultra control panels. As well as the Hornet+ network, networking via TCP-IP (max. 20 Cluster) is also managed.



Manages extinguishing systems

Previdia Compact control panels with the extinguishing function are capable of managing an extinguishing channel. When combined with a HORNET+ network, they can operate as satellite control units for Previdia Max and Previdia Ultra expandable control panels.

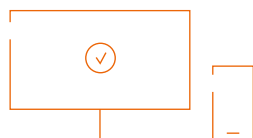

Always connected

Thanks to the on-board Ethernet port, the control panel is capable of both connecting to the Inim Fire Cloud, thus remaining accessible at all times via PC or App, and of carrying out remote monitoring via TCP-IP through SIA-IP and MODBUS protocols.

Installing a Previdia-C-DIAL optional module, allows the control panel to manage voice and digital communications over a wired telephone line and a 3G line, as well as record and replay voice messages and send automated SMS text.



Inim Fire App

Remote management via App (for Android and iOS) with video verification functions, interactive graphic maps, system register management, maintenance recording, diagnostics and an innovative Walk Test function.



Up to 480 connectable devices

Compact analogue-addressable control panel capable of managing, depending on the model, 1 x 64-point loop, 1 x 240-point loop or 2 x 240-point loops.

Intelligent

- 1000 configurable zones
- 1000 output groups for activation logics
- Logical equations
- Timers

Easily programmable

From the front plate or via the Previdia/STUDIO configuration software available on the Inim website.

Self-powered

1.5 A or 4 A power-supply with integrated battery charger.

4.3" graphic display

Colour touch-screen, customizable display with images, status indication icons for the various elements, text and function buttons.

Fully configurable

4 I/O channels of 1A + 1 fully configurable on-board relay

Gas extinguishing

Management of a gas-extinguishing channel (depending on the model), certified EN12094-1.

Protocols

HORNET+ network interface and Ethernet on board for networking between control panels. Integrated MODBUS protocol on TCP-IP for connection to BMS software.

Always connected

Cloud connection through the on-board Ethernet port.



ORDER CODES	Loop CAPACITY			CABINET		ZONE STATUS LED	EXTINCTION MANAGEMENT
	1 Loop of 64 points	1 Loop of 240 points	2 Loops of 240 points	Small, with 1.5 A power-supply and 7 Ah batteries	Large, with 4 A power-supply and 17 Ah batteries	Zone LED available	Includes an extinguishing channel
C050S	✓			✓			
C100S		✓		✓			
C200S			✓	✓			
C050L	✓				✓		
C100L		✓			✓		
C200L			✓		✓		
C050SZ	✓			✓		✓	
C100SZ		✓		✓		✓	
C200SZ			✓	✓		✓	
C200LZ			✓		✓	✓	
C050SZE	✓			✓		✓	✓
C100SZE		✓		✓		✓	✓
C200SZE			✓	✓		✓	✓
C200LZE			✓		✓	✓	✓

S: 325 x 325 x 80 mm L: 497 x 380 x 87 mm | It is possible to customize the colour of the cabinet by adding the final letter: **G**) Grey - **R**) Red - **D**) Dark-grey



Previdia Compact control panel diagram

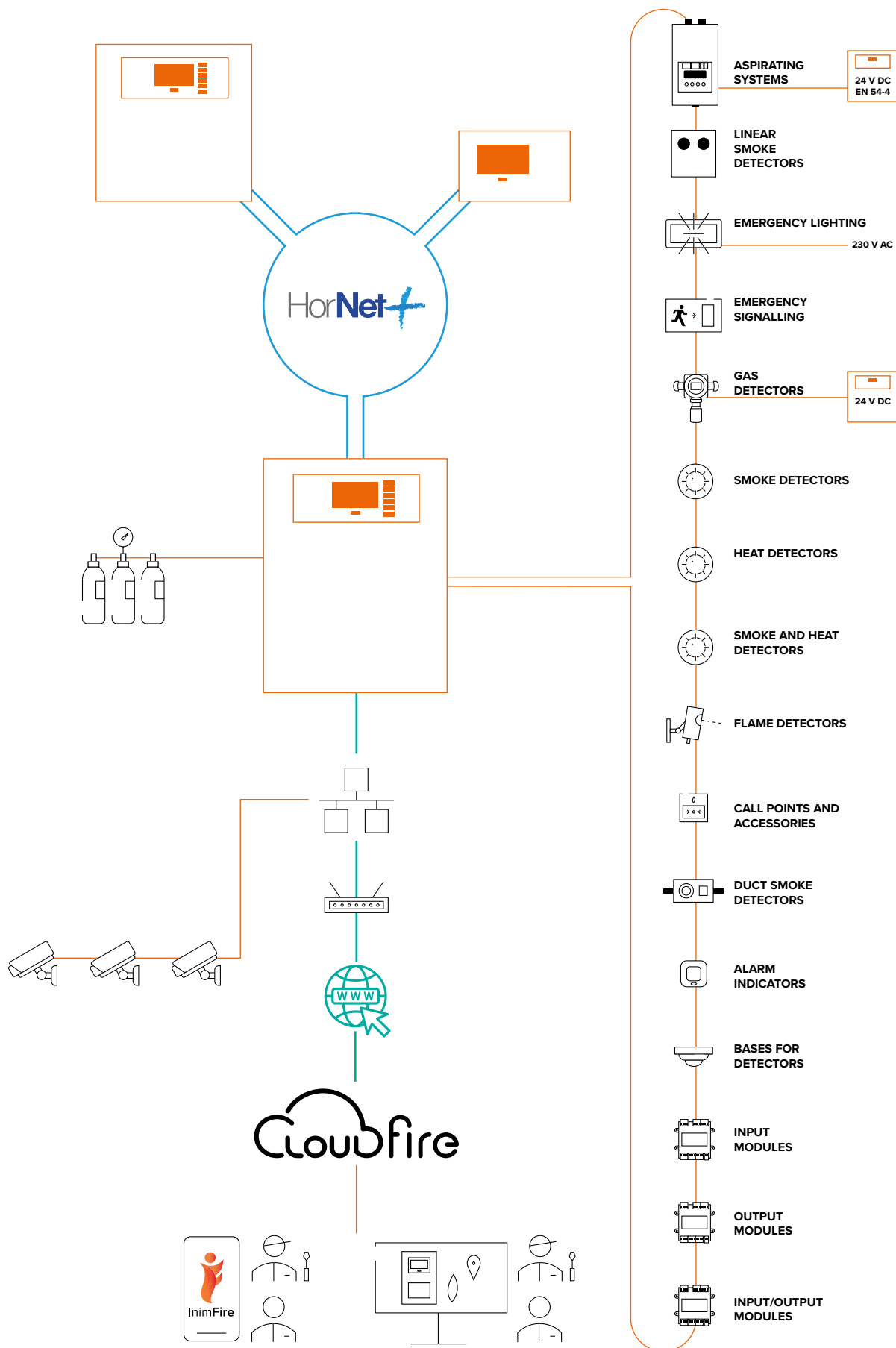



Accessories for Previdia Compact

PREVIDIA-C-DIAL

REMOTE COMMUNICATOR MODULE



Manages remote communications via wired telephone lines and 3G GSM networks. Capable of managing voice calls, recording up to 100 voice messages, SMS with automatic text generation and digital calls using the most widely used protocols.

TECHNICAL SPECIFICATIONS

Power supply voltage:	19 / 30 V
Stand-by current draw:	40 mA
Maximum current draw:	140 mA
2G/3G frequency band:	850/900, 1800/1900 MHz - 800/850/900, 1900/2100 MHz
Maximum RF output power:	2 W, 1 W
Operating temperature:	-5° ... +40° C

PREVIDIA-C-COM / PREVIDIA-C-COM LAN

SERIAL COMMUNICATIONS MANAGEMENT MODULE



PREVIDIA-C-COM provides two RS232 ports and two RS485 ports for the connection of remote communicators, using the protocols available in the table.

COMMUNICATION PROTOCOL	RS232	RS485
ESPA444	✓	Protocol for interfacing with control panels to pagers, third-party remote communicators
PASO		✓ Protocol for interfacing between the control panel and the Voice EVAC-system
WEB WAY ONE	✓	Protocol for interfacing with WEB-WAY-ONE remote communicators
SMART-485-IN		✓ Communication protocol with the Inim SMART-485 IN module which allows connection to the standard interface panels required in some countries
LOG ON SERIAL - ASCII PRINTER	✓	Sends events to the port in real time in ASCII format (to a printer or receiving devices)
LOG ON SERIAL - SMART LOOP FORMAT	✓	Sends events to the port in real time in the format used by SmartLoop series control panels
LOG ON SERIAL - PLUS II PRINTER FORMAT	✓	It sends events to the port in real time in compatible format for Custom PLUSII printers
LOG ON SERIAL - WITHOUT CONTROLS	✓	Sends events to the port in real time in ASCII format without any control for the printers

PREVIDIA-C-COM-LAN provides, in addition, a socket for connection to the Ethernet network for advanced TCP-IP functions such as sending e-mails, an interactive WEB page with graphic maps, video verification via connection to IP cameras with ONVIF protocol, BACnet protocol (subject to PRE- BACLIC) and interfacing with TUTONDO EVAC systems (via TCP-IP).

TECHNICAL SPECIFICATIONS

Power supply voltage:	19 / 30 V
Current draw:	40 mA
RS485 maximum current draw:	200 mA
SDCard capacity (for Previdia-C-COM-LAN only):	32 GB
Operating temperature:	-5° ... +40° C

PREVIDIA-C-REP / PREVIDIA-C-REPE

REMOTE CONTROL KEYPAD (REPEATER)

 EN54-2



PREVIDIA-C-REP with customizable 4.3" touchscreen LCD, buttons for basic functions and status LEDs. Connects to the HORNET+ network (dual RS485 connection) or via ETHERNET TCP-IP network. It provides detailed information about the entire network. Internal buzzer. Level 2 via key or code.

PREVIDIA-C-REPW Enclosure in white plastic

PREVIDIA-C-REPR Enclosure in red plastic

PREVIDIA-C-REPE provides, in addition, indication relating to the extinguishing channel.

PREVIDIA-C-REPW Enclosure in white plastic

PREVIDIA-C-REPR Enclosure in red plastic

TECHNICAL SPECIFICATIONS

Power supply voltage:	19 / 30 V	Version dimensions (S):	210 x 132 x 32 mm
Stand-by current draw:	110 mA	Weight:	330 g
Current draw during mains failure:	80 mA		
Maximum current draw:	130 mA		
Operating temperature:	-5° ... +40° C		



Previdia Max

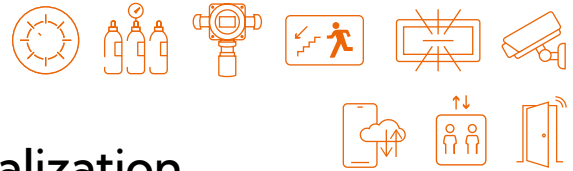

Modular control panel for the realization of fire detection and extinction systems

Previdia Max control panels can comprise a single cabinet or multiple cabinets (max. 4) hooked together. Can be used individually or interconnected in a network, the network connection can be achieved through an RS485 BUS, via a TCP-IP connection or by means of a combination of both.



TECHNICAL SPECIFICATIONS

Power supply voltage:	230 V ~ (+10% - 15%); 115 V ~ (+10% - 15%) 50/60 Hz	Dimensions:	433 x 563 x 187 mm
Maximum absorption from the 230V line:	1.1 A @ 230 V 2 A @ 115 V	Weight (without batteries):	10 Kg
Nominal output voltage:	27.6 V	Package dimensions:	500 x 620 x 250 mm
Maximum output current:	4 A		
Current for battery charger:	1.2 A		
Battery specifications:	2 x 12 V 24 Ah o 2 x 12 V 17 Ah		
Operating temperature:	-5° ... 40° C		
Enclosure protection grade:	IP30		



See the online section



EN54 certified

Previdia Max has obtained all the applicable EN54 certifications:

- EN54-2 : Control panel and signalling devices;
- EN54-4 : Power supply units;
- EN54-21 : Alarm transmission and remote fault signalling and warning equipment;
- EN12094-1 : Gas extinguishing system components. Automatic electrical command and shutdown and delay management devices;
- EN54-13 : Compatibility of system components.

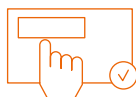

Simple installation

Thanks to its graphic colour touchscreen, Previdia Max simplifies configuration, management and maintenance of the system and makes almost effortless what was until today time consuming and complicated.



Intuitive

Thanks to on-screen graphic maps and video verification via IP cameras for the immediate location of the specific point of alarm detection, Previdia Max drastically reduces intervention time in the event of real danger and reduces the false alarm rate.

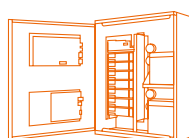

Flexible

Thanks to its modular architecture, Previdia Max offers a system that is suitable for all types of installations, from small business premises to large airports, hotels and shopping malls. Each control panel can be made up of a maximum of four cabinets and is capable of managing up to 32 IFM modules.

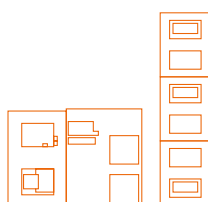

Flexible

Thanks to its structure of distributed intelligence with a microprocessor inside each module and redundant in the main unit and the possibility of having a main backup unit, Previdia Max guarantees unparalleled reliability. The security of the system is no longer entrusted to a single processing unit but to a group of interconnected CPUs which operate in synergy to provide the fastest and most effective response.

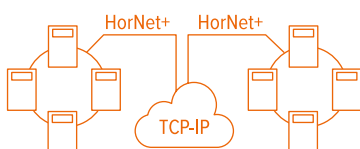

Networkable

Thanks to its powerful network architecture, Previdia Max allows the realization of hybrid systems based on connections using bights, fiber optics and TCP-IP networks capable of overcoming all barriers and of reaching unprecedented cover. Each cluster of control panels interconnected through a HorNet+ network can support up to 48 control panels, and up to 20 clusters can be connected through a TCP/IP network.

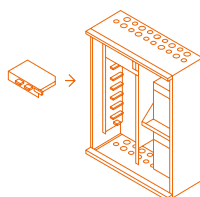

Robust

Thanks to HOT SWAP technology, modules can be added or replaced without shutting down the system, thus providing Previdia Max with a fast, safe method of intervention without any services interruptions.

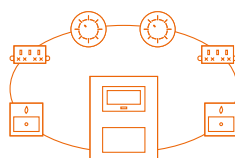

Reliable

Thanks to loop control modules equipped with "power up boosters", Previdia Max allows you to set the operating temperature of each separate cable thus ensuring reliability and wiring simplicity.

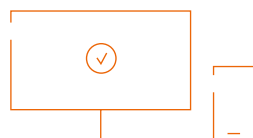

Always connected

Thanks to the intensive use of new technologies such as the Web Server, electronic mail, TCP-IP connections, Cloud, Apps for SmartPhones and GSM communications, Previdia Max provides a system that is always under control and in reach. Both for the end-user and control and maintenance personnel.



Installation modes



Single cabinet systems

If the Previdia Max control panel is configured in a single cabinet, it will be possible to house a second FPM module on the front plate, in addition to the primary CPU unit essential for operation.

The CAN DRIVE interconnection bar is located inside the cabinet for the housing of a maximum of 8 IFM modules in accordance with system requirements.

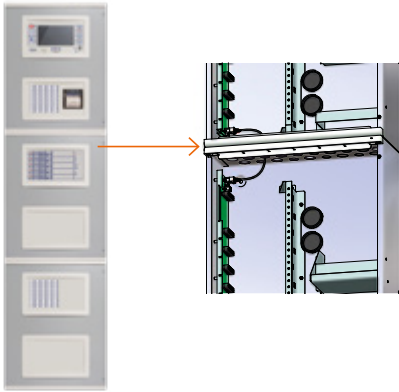

Multi-cabinet control panels

In order to expand the capacity of each control panel, several cabinets (maximum 4) can be assembled together to form a cabinet of increased dimensions.

The cabinets can be assembled together by means of the mounting screws (supplied), once assembled the CAN DRIVE bars can be connected together using the wire (supplied).

The assembled cabinets provide the respective number of housings for the front plate and CAN DRIVE bar modules. An IFM24160 power supply module can be installed in each cabinet, the different power supplies will automatically share the load current between them.

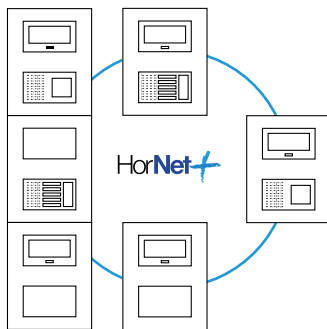

Control panels in a HorNet+ network

The system can be expanded by simply connecting other control panels (maximum 48) in such a way as to constitute a system with increased capacity (HorNet+ network).

In order to connect two or more control panels in a HorNet+ network, an IFMNET module must be installed inside each control panel which, via the two RS485 ports, will allow the ring connection to be made.

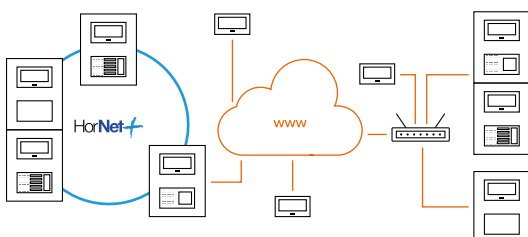

Control Panels in an IP network

Several control panels or HorNet+ networks of control panels can be connected together by means of a TCP-IP connection.

Each node of such a connection type is identified as a "Cluster"; each "Cluster" can be made up of a single control panel, a HorNet+ network of control panels or a Repeater.



Networkable

Up to 48 control panels in a HORNET+ network using the IFMNET network board and Up to 20 clusters connectable via TCP/IP.

Intelligent

Control equations for activations with logical operators (And, Or, Not, Xor, etc.), 1000 software zones, 1000 logic groups, 500 trigger activations, 100 programmable actions.

Multimedia

Clear and simple indications through graphic maps and alarm video verification via IP cameras.

Intuitive

7" touchscreen display 65,000 colours with second emergency CPU.

Modular

2 loops expandable to 16 (3840 points), multi-processor hardware architecture

Expandable

Possibility of interconnecting up to a maximum of 4 cabinets, up to 32 IFM internal modules and 8 FPM frontal modules.

Powerful

Up to 4 internal power supplies (IFM24160) and 4 battery packs (in the multiple cabinet configuration) and a maximum of 24 extinguishing channels (via IFMEXT modules).

Advanced

Management of MODBUS RTU, MODBUS-IP protocols and, via IFMLAN module, BACNET IP, ESPA 444, SIA-IP.

Certified

- Certification LPCB / IMQ / UL-EU;
- Certification EN54 pt2 / 4 / 21 / 13;
- Certification EN12094-1 (fire extinguishing systems) up to 24 channels.

ORDER CODES	Loop CAPACITY	MODULAR AND NETWORKABLE	CABINET COLOUR	
	2 Loops expandable to 6		Grey	Red
Previdi216	✓	✓	✓	
Previdi216R	✓	✓		✓

Each installation must start from a basic Previdi216 control panel to which, when necessary, can be added function modules, cabinets and accessory devices. The basic configuration consists of a cabinet and the following accessories:

FPMCPU



Control unit with display

IFM24160



4A power-supply modules with built-in battery charger

IFM2L



Module for the management of 2 loops

Previdia Max control panel diagram

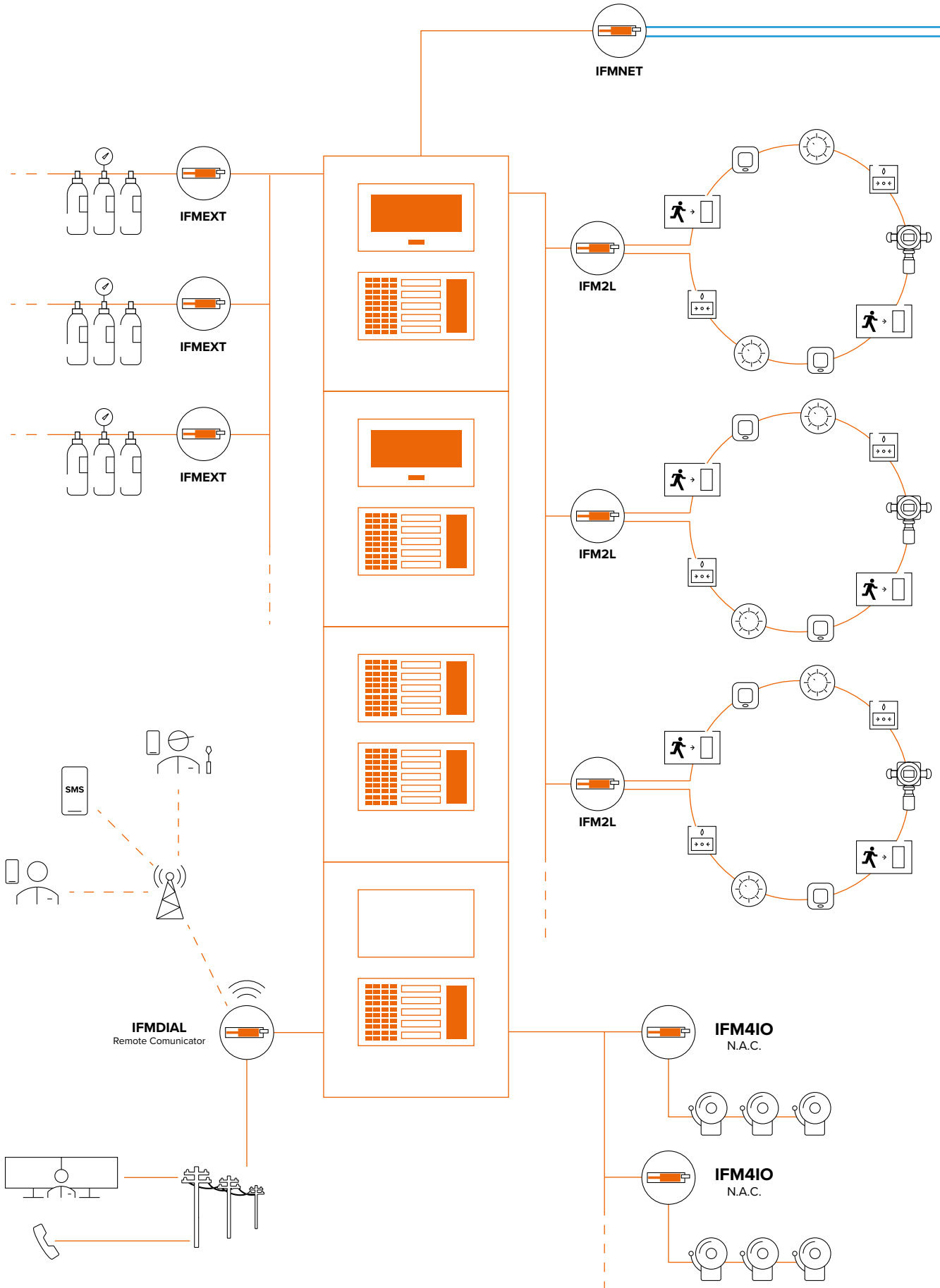

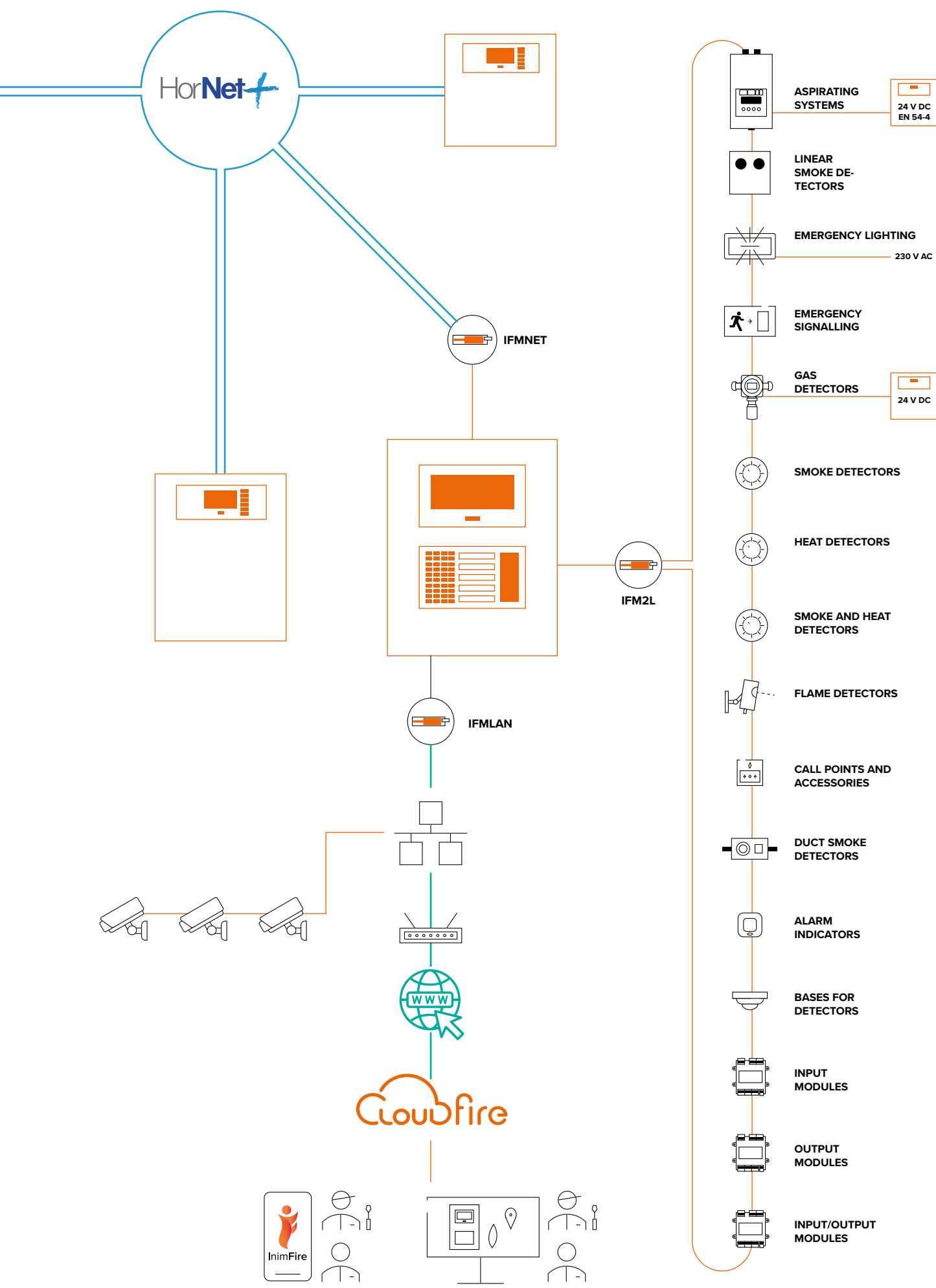



Accessories

These allow you to expand the control panel (additional cabinets) or to make installations according to cabling requirements.

PRCAB ADD-ON CABINET

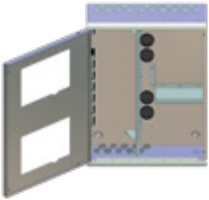

Complete with front plate (door), CAN DRIVE bar for the connection of function modules (max. 8), battery shelves. There are two openings on the front plate (door) in which two FPM modules can be located (if no particular functions are required, two blind modules FPMNUL can be added).

PRCABR Red cabinet

TECHNICAL SPECIFICATIONS

Protection grade:	IP30	Dimensions:	433 x 563 x 187 mm
Housed batteries:	2 x 12 V 24 Ah o 2 x 12 V 17 Ah	Weight (without batteries):	10 Kg
		Package dimensions:	500 x 620 x 250 mm

PRCABSP KIT FOR DISTANCING THE CABINET FROM THE WALL

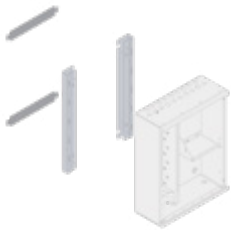

Pair of brackets for mounting the cabinet 5 cm from the wall, to be used for cable routing.

PRCABSPR
Mounting bracket in red

PRCABRK KIT FOR MOUNTING CABINET TO 19" RACK

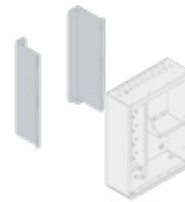

Bracket for fixing the cabinet inside a 19" rack.

PRREP ENCLOSURE FOR MOUNTING FPMCPU MODULE AS REMOTE REPEATER

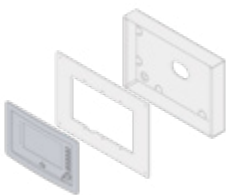

Comprises a brushed aluminium plate and a metal backbox, can be wall or surface mounted.

TECHNICAL SPECIFICATIONS

Dimensions of Front plate (door):	368 x 256 x 2.5 mm
Dimension of Flush-mount backbox:	356 x 244 x 56 mm
Weight:	250 g

INDSIN1PPRAEDEMOMO DEMO CASE FOR THE PREVIDIA SYSTEM



Demo Case for Previdia Max system, practical case containing Previdia 216 control panel and several already-connected Loop devices. Useful for technical trainings.



FPM modules

(Front Panel Module)

Compatible with the Previdia Max and Previdia UltraVoxm control panels, to be housed on the front plate (door) of the cabinets, a maximum of two for each cabinet.

FPMCPU

FRONT PANEL CPU MODULE AND REPEATER



Main control panel equipped with a 7" graphic 65000 colour touchscreen. This device manages the control panel and co-ordinates the various function modules. The module can also be used as a Remote keypad (Repeater) connected to the RS485 line of the Control panel (max 14 Repeaters in series) or via TCP-IP network. If used as a remote keypad the module must be combined with the PRREP enclosure.

- Ethernet connection for networking and remote control
- RS485 channel for repeaters (FPMCPU used as remote keypads - max. 14)
- RS485 port for interfacing with BMS, MODBUS RTU protocol management
- Mini USB Port for configuration via PC
- RS232 Port for configuration via PC
- Dual CPU, a main and a emergency backup that will take over in the event of fault
- Housing for the SD-card
- Customization of user interface, icons, buttons etc.

FPMCPU-L Light-grey plastic

FPMCPU-G Dark-grey plastic

TECHNICAL SPECIFICATIONS

Power supply voltage:	19 ÷ 30 V DC	Dimensions:	185 x 288 x 82 mm
Consumption @ 27.6 V:	stand-by 120 mA; max. 140 mA	Weight (without batteries):	900 g
Maximum output current:	@ 27.6 V 1 A	Package dimensions:	325 x 620 x 250 mm
Operating temperature:	-5° ... +40° C		

FPMLED

LED MODULE

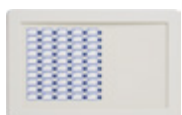

Module equipped with 50 configurable tri-colour LED (green, yellow and red), it provides instant visual signals relating to the status of the various system elements (zones, points, etc.).

FPMLED-L Light-grey plastic

FPMLED-G Dark-grey plastic

TECHNICAL SPECIFICATIONS

Power supply voltage:	19 ÷ 30 V DC	Dimensions:	185 x 288 x 52 mm
Consumption @ 27.6 V:	stand-by 12 mA; max. 35 mA	Weight (without batteries):	690 g
Operating temperature:	-5° ... +40° C	Package dimensions:	325 x 620 x 250 mm

FPMLEDPRN

LED MODULE AND THERMAL PRINTER



Module equipped with 50 tri-colour LEDs as per the FPMLED module and an 56mm thermal printer. It provides real-time printouts of all system events.

FPMLEDPRN-L Light-grey plastic

FPMLEDPRN-G Dark-grey plastic

TECHNICAL SPECIFICATIONS

Power supply voltage:	19 ÷ 30 V DC	Dimensions:	185 x 288 x 52 mm
Consumption @ 27.6V:	stand-by 45 mA; max. 45 mA	Weight (without batteries):	690 g
Operating temperature:	-5° ... +40° C	Package dimensions:	325 x 620 x 250 mm



FPMEXT

LED SIGNALLING MODULE FOR FIRE-EXTINGUISHING CHANNELS



If IFMEXT function modules are housed inside the control panel, it is mandatory to use one or more FPMEXT modules to visualize the status as indications separate from the display. Each FPMEXT module provides the signals from 5 IFMEXT extinction modules.

- FPMEXT-L** Light-grey plastic
- FPMEXT-G** Dark-grey plastic

TECHNICAL SPECIFICATIONS

Power supply voltage:	19 ± 30 V DC	Dimensions:	185 x 288 x 52 mm
Consumption @ 27.6V:	stand-by 12 mA; max. 35 mA	Weight (without batteries):	690 g
Operating temperature:	-5° ... +40° C	Package dimensions:	325 x 620 x 250 mm

FPMNUL

BLIND MODULE



To be used to seal the apertures on the doors of the metal cabinet when specific functions are not required.

- FPMNUL-L** Light-grey plastic
- FPMNUL-G** Dark-grey plastic

TECHNICAL SPECIFICATIONS

Dimensions:	185 x 288 x 52 mm
Weight (without batteries):	690 g
Package dimensions:	325 x 620 x 250 mm

IFM Modules (Internal Fire Module)

Compatible with the Previdia Max and Previdia UltraVox control panels, the IFM series modules must be inserted on the CAN DRIVE bar inside the cabinets (max. 8 IFM modules for each cabinet) in accordance the required functions.

IFM24160

SWITCHING POWER-SUPPLY MODULE



Connects to the mains power supply and supplies a maximum 4 A current to the system. Houses a 1.2 A battery charger capable of maintaining under charge two 17 Ah or 24 Ah batteries. Houses 2 supervised outputs and a relay output, both configurable (factory configured as alarm output, AUX output and fault signaling relay). Only one power supply module can be housed inside each metal cabinet. CPU dedicated to the control of the module and communication with the control-panel FPMCPU module.

TECHNICAL SPECIFICATIONS

Power supply voltage:	230 / 115 V~ (+10% -15%) 50/60 Hz	Package dimensions:	90 x 110 x 185 mm
Maximum current draw from mains:	1.1 A @ 230 V, 2 A @ 115 V	Weight with packaging:	1000 g
Output voltage:	27.6 V		
Maximum available current:	5.2 A		
Current for battery charger:	1.2 A		
Batteries:	2x 12 V 24 Ah o 2x 12 V 17 Ah		
Consumption @ 27.6 V:	stand-by 20 mA, maximum 40 mA		
Maximum output current OUT1 and OUT2:	1.5 A @ 27.6 V		
Maximum current on relay:	5 A @ 30 V		
Operating temperature:	-5° ... +40° C		

IFM2L

MODULE FOR THE MANAGEMENT OF TWO LOOPS



Capable of managing up to 240 devices per Loop. The module contains a step-up switching power-supply module for each Loop, capable of maintaining the operating voltage (during alarm and stand-by conditions) at the set values. Each control panel manages up to 8 IFM2L modules

- CPU dedicated to the control of the module and communication with the control-panel FPMCPU module
- “Power up boosters” technology, possibility to set the operating voltage during stand-by and alarm status for each individual loop
- Communication protocol: Inim, Argus, Apollo

TECHNICAL SPECIFICATIONS

Power supply voltage:	19 ÷ 30 V DC	Dimensions:	175 x 110 x 40 mm
Consumption @ 27.6 V:	stand-by 35 mA, max. 50 mA	Package dimensions:	180 x 125 x 50 mm
Maximum voltage on Loop:	0.5 A	Weight with packaging:	280 g
Operating temperature:	-5° ... +40° C		

IFM4R

CONFIGURABLE 4 RELAY MODULE



Each relay supports a maximum load of 5 A @ MAX. 30 V. Each control panel can manage a maximum of 16 IFM4R modules.

- CPU dedicated to the control of the module and communication with the control-panel FPMCPU module
- 4 relays (NC / C / NO)

TECHNICAL SPECIFICATIONS

Power supply voltage:	19 ÷ 30 V DC	Dimensions:	175 x 110 x 40 mm
Consumption @ 27.6 V:	stand-by 10 mA, max. 80 mA	Package dimensions:	180 x 125 x 50 mm
Maximum current on relay:	5 A @ 30 V	Weight with packaging:	280 g
Operating temperature:	-5° ... +40° C		

IFM4IO

4 POWER INPUT/OUTPUT MODULE



Each control panel can manage a maximum of 16 IFM4IO modules. Each of the 4 channels can be configured as:

- supervised output capable of supplying a maximum current of 1 A @ 27.6 V, configurable
- supervised input capable of activating warning, pre-alarm and alarm signals, configurable
- conventional zone capable of managing a line of conventional detectors, maximum 32 detectors, configurable
- 4-20 mA input capable of reading 4-20 mA detector signals; settable intervention thresholds, configurable
- CPU dedicated to the control of the module and communication with the control-panel FPMCPU module
- 4 fully-programmable I/O terminals

TECHNICAL SPECIFICATIONS

Power supply voltage:	19 ÷ 30 V DC	Dimensions:	175 x 110 x 40 mm
Consumption @ 27.6 V:	stand-by 22 mA, max. 170 mA	Package dimensions:	180 x 125 x 50 mm
Maximum voltage on I/O:	1 A @ 27.6 V	Weight with packaging:	280 g
Operating temperature:	-5° ... +40° C		



IFMDIAL

PSTN AND GSM REMOTE COMMUNICATOR MODULE



It is capable of sending voice calls resulting from on-board recorded messages and digital calls via the most widely used protocols (SIA, Contact ID, etc.). This module is also capable of sending SMS messages with detailed texts relating to the saved events. Each control panel manages one IFMDIAL module only.

Note - GSM antenna not supplied. Available as an accessory: LTE-ANT100B.

- CPU dedicated to the control of the module and communication with the control-panel FPMCPU module
- GSM antenna connector (requires GSMANT200N antenna)
- Housing for the SIM-card
- Frequency bands: 850, 900, 1800 and 1900 Mhz
- 1 terminal for the connection of the internal telephone line
- 1 terminal for the connection of the external telephone line (PSTN)
- 100 voice messages on-board (up to 15 min.) recordable via software with text-to-speech or wav file
- Up to 100 telephone actions
- 100 customizable SMS text messages
- Automated SMS text
- Integrated automatic digital communicator (Contact ID, ADEMCO etc.)
- 15 telephone numbers for dialler functions (voice, digital, SMS)

LTE-ANT100B High performance GSM antenna, white.

TECHNICAL SPECIFICATIONS

Power supply voltage:	19 ÷ 30 V DC	Dimensions:	175 x 110 x 40 mm
Consumption @ 27.6 V:	stand-by 30 mA, max. 250 mA	Package dimensions:	180 x 125 x 50 mm
Operating temperature:	-5° ... +40° C	Weight with packaging:	280 g

IFM16IO

16 LOW-POWER INPUT/OUTPUTS MODULE

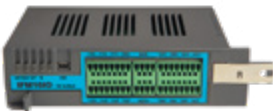

Each control panel is capable of managing up to 4 IFM16IO modules. This module also provides terminals for the ancillary power @ 27V. Each channel can be configured as:

- Digital input (non supervised) activated with voltage present
- Digital output (non supervised) capable of supporting a maximum load of 100 mA @ 30 V DC
- CPU dedicated to the control of the module and communication with the control-panel FPMCPU module
- 16 input/output connection terminals
- 2 terminals for power supplying to external loads

TECHNICAL SPECIFICATIONS

Power supply voltage:	19 ÷ 30 V DC	Dimensions:	175 x 110 x 40 mm
Consumption @ 27.6 V:	stand-by 12 mA, max. 25 mA	Package dimensions:	180 x 125 x 50 mm
Operating temperature:	-5°C ... +40°C	Weight with packaging:	280g

IFMNET

MODULE FOR THE CONNECTION OF MORE CONTROL PANELS IN A HORNET+ NETWORK (UP TO 48)



Provides two RS485 ports for connection with other control panels; the wiring must be completed in a closed loop. RS485 speed settable from 9600 to 512k baud, a 12 V output is provided for the power supply to eventual RS485 optic fiber converters. Each control panel manages one IFMNET module only. All the interconnected control panels in the network must be equipped with an IFMNET module.

- CPU dedicated to the control of the module and communication with the control-panel FPMCPU module

TECHNICAL SPECIFICATIONS

Power supply voltage:	19 ÷ 30 V DC	Dimensions:	175 x 110 x 40 mm
Consumption @ 27.6 V:	60 mA	Package dimensions:	180 x 125 x 50 mm
Maximum output current 12 V:	0.8 A	Weight with packaging:	280 g
Operating temperature:	-5° ... +40° C		

IFMLAN

ADVANCED TCP-IP SERVICE MANAGEMENT MODULE



Each control panel manages one IFMLAN module only. Allows a second control panel connection to the Ethernet network and provides the following services:

- Connection to Inim Fire Cloud
- Web-server for control, management and maintenance of the system accessible via PC/ smartphone
- Sends emails in response to each system event
- Up to 32 email addresses and/or IP addresses for notifications
- Dual CPU, one dedicated to control of the module and communication with the control-panel FPMCPU module, the other with LINUX operating system dedicated to the control of the IP connection
- Ethernet port for a second TCP-IP connection
- RS485 and RS232 port
- Housing for the SD-card (max. 32Gb)
- Up to 100 actions
- Videoverification of alarms, with eventual sending of emails with photoshot attachments
- Manages up to 100 IP cameras (ONVIF, profile S)
- Manages SIA-IP, IP Bacnet (requires PRBAC-IP license), ESPA 4.4.4, NTP, UPnP, SSL
- Manages voice evacuation systems through IP interface or RS232

TECHNICAL SPECIFICATIONS

Power supply voltage:	19 ÷ 30 V DC	Dimensions:	175 x 110 x 40 mm
Consumption @ 27.6 V:	45 mA	Package dimensions:	180 x 125 x 50 mm
Operating temperature:	-5° ... +40° C	Weight with packaging:	280 g

IFMEXT

MODULE FOR THE MANAGEMENT OF A GAS EXTINGUISHING CHANNEL.



Provides terminals for the management of devices which are commonly requested in this type of installation together with the adequate activation logic. The various functions available on the terminals can be replicated on devices connected to the loop (with the exception of control of the electrovalve). Each control panel manages up to 24 IFMEXT modules. The modules must be associated with the FPMEXT signalling panel. Each FPMEXT module reports the visual signals of a maximum of 5 IFMEXT modules.

- CPU dedicated to the control of the module and communication with the control-panel FPMCPU module
- 1 input terminal for PRESSOSTATE SWITCH control with programmable functions
- 1 input terminal for STOP EXTINGUISHING with programmable functions
- 1 input terminal for MANUAL EXTINGUISHING
- 1 output terminal for VALVE command
- 1 output terminal for HOLD extinguishing signal
- 1 output terminal for PRE-EXTINGUISHING signal
- 1 output terminal for gas RELEASED signal

TECHNICAL SPECIFICATIONS

Power supply voltage:	19 ÷ 30 V DC	Dimensions:	175 x 110 x 40 mm
Consumption @ 27.6 V:	stand-by 30 mA, max. 80 mA	Package dimensions:	180 x 125 x 50 mm
Maximum current on VALVE output:	2 A @ 27.6 V	Weight with packaging:	280 g
Maximum current on output:	1 A @ 27.6 V		
Operating temperature:	-5° ... +40° C		



Previdia UltraVox



EVAC and fire detection integrated in a single product

Previdia UltraVox control panels add Voice Evacuation and Public Address functions to the functions shared by the other two models in the range. Previdia UltraVox models house the CANDRIVE+ connection bar inside their cabinets and are compatible not only with the function modules described below, but also with the FPM (Front Panel Module) and IFM modules (Internal Fire Module) of the Previdia Max model.



TECHNICAL SPECIFICATIONS

Power supply voltage:	90 ~ 264 V AC / 47 ~ 63 Hz	Dimensions:	675 x 430 x 260 mm
Maximum current draw:	8.5 A @ 115 V AC / 5A @ 230 V AC	Weight without batteries:	23 Kg
Output voltage:	26 V bc nominal / 20 - 27.6 V	Cabinet colour:	grey RAL7042 / red RAL3001
Output voltage on speaker lines:	100 Vrms	IP protection grade:	IP30
Max output current from the power supply module:	38 A	Maximum power manageable:	1000 W for each power-supply module
Current available for the system:	35 A		
Maximum battery-charge current:	3 A		
Batteries:	2 x 12 V 17 Ah / 2 x 12 V 24 Ah / 2 x 12 V 38 Ah		
Operating temperature:	-5° C .. 40° C		



See the online section



EN54 certified

It has obtained all the certifications applicable to control systems for fire detection and alarm systems, control equipment for extinguishing systems and control systems for EVAC voice evacuation systems.

EN54-2, EN54-4, EN54-16 EN54-21, EN12094-1, EN54-13.

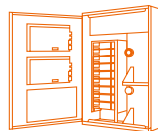

Flexible

Thanks to its modular architecture, it adapts to any type of installation, from small business premises to airports, large hotels and shopping malls. Each control panel can be made up of a maximum of four cabinets and is capable of managing up to 32 IFM or IFAM modules.

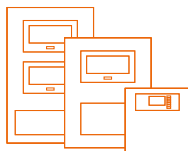

Integrated system

Combines the functions of fire detection and alarm signalling, extinguishing control, gas detection, emergency lighting with PA functions (Public addressing - audio entertainment) and VA (Voice Alarm or EVAC) functions.

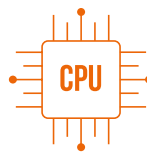

Intelligent

Based on a distributed intelligence architecture with a microprocessor inside each module.

Redundant microprocessor in main unit, DSP for audio processing in audio matrix module.



Digital audio

Thanks to the DSP inside its audio matrix, it is capable of processing a multitude of external analogue audio sources and audio files saved to its memory.

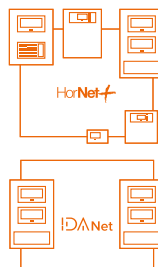

Structured

The architecture allows the creation of hybrid networks based on connection via twisted pair cable, optical fiber and TCP-IP in order to share all the information and audio tracks (audio shared only within the IDANET network) among the various nodes. Each Hornet+ or IDANET network cluster can connect up to 48 control panels, up to 20 clusters can be interconnected via TCP-IP network.

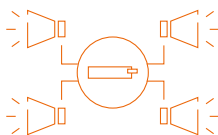

Shared audio

Network shared digital audio, up to 50 digital audio tracks can be shared amongst the various nodes of the IDANET network.

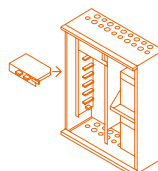

Robust

HOT SWAP technology allows the "hot" replacement or addition of modules (without shutting down the system) for quick, safe intervention and without interrupting service. Manages Backup Amplifier without any additional wiring.



Class D amplifiers

Up to 30 Class D amplifier modules per control panel characterized by high efficiency and a maximum power of 250W each.



Easy

A single control panel capable of controlling all the security functions of the building. Configuring evacuation procedures with control interfaces becomes very easy.



Intuitive

Thanks to the dual LCD, graphic maps, video verification, it drastically reduces response and intervention times. The EVAC section user interface can be configured to increase ease-of-use or flexibility, depending on the technical preparation of the personnel in charge.

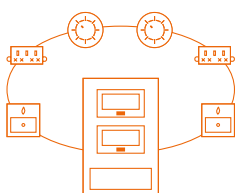

Reliable

Loop management modules equipped with "power up booster" to set the operating voltage of each individual circuit, ensuring reliability and cabling simplicity.

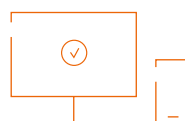

Multimedia

Web-server, e-mail, TCP-IP connections, Cloud, APP for SmartPhones, telephone and GSM communications, allow system control on hand at all times. Both for the end-user and control and maintenance personnel.





Single cabinet systems

The control panel can house the FPM or FPAM modules on the front plate. In the single cabinet configuration the UltraVox version is supplied with two control modules: FPMCPU for fire functions and FPAMIAS for PA-VA functions. The CANDRIVE+ interconnection bar is located inside the cabinet and provides placements for up to 8 IFM or IFAM modules.

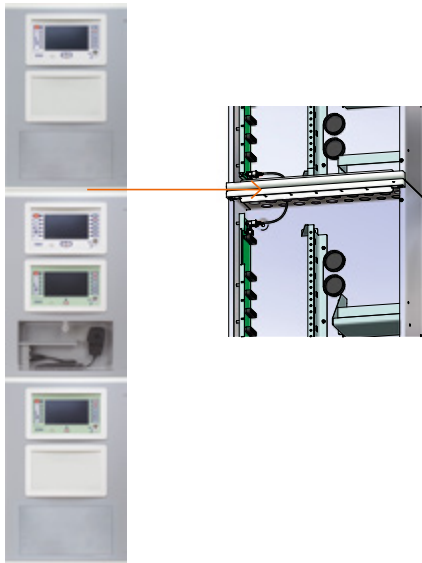

Multi-cabinet control panels

In order to expand the capacity of each control panel, several cabinets (maximum 4) can be assembled together to form a cabinet of increased dimensions.

The cabinets must be joined using the screws provided and, once mechanically joined, the CANDRIVE+ bars must be connected to each other via the supplied cables.

Once several cabinets have been joined together there will be multiple placements for FPM or FPAM front panel modules or IFM or IFAM modules. Each cabinet can house an IFAMPSU power-supply module.

Control panels in a HORNET+ network

HORNET+ technology allows network connection between Previdia UltraVox, Previdia Max and Previdia Compact control panels. Based on token ring architecture, each section is based on RS485 and must be made using a shielded twisted pair (Ethernet cable) up to a distance of 500m. This allows the sharing of all the system information but not the audio tracks.

Control Panels in an IDANET network

IDANET technology, based on ring architecture in which each section can be made using CAT5 Ethernet cable (up to 100m) or via optical fiber (by inserting an appropriate SFP module depending on the type of fiber used), as well as sharing all information between the various control panels and effectively making them a single system, it is also capable of sharing up to 50 audio tracks, allowing sound sources to be conveyed from one node of the system to another.

Control Panels in an IP network

Each "cluster" created using IDANET or HORNET+ technology (or single control panel) can be connected via TCP-IP with up to a maximum of 20 other clusters. This type of networking makes it possible to take advantage of existing LAN networks in order to interconnect control panels with each other.

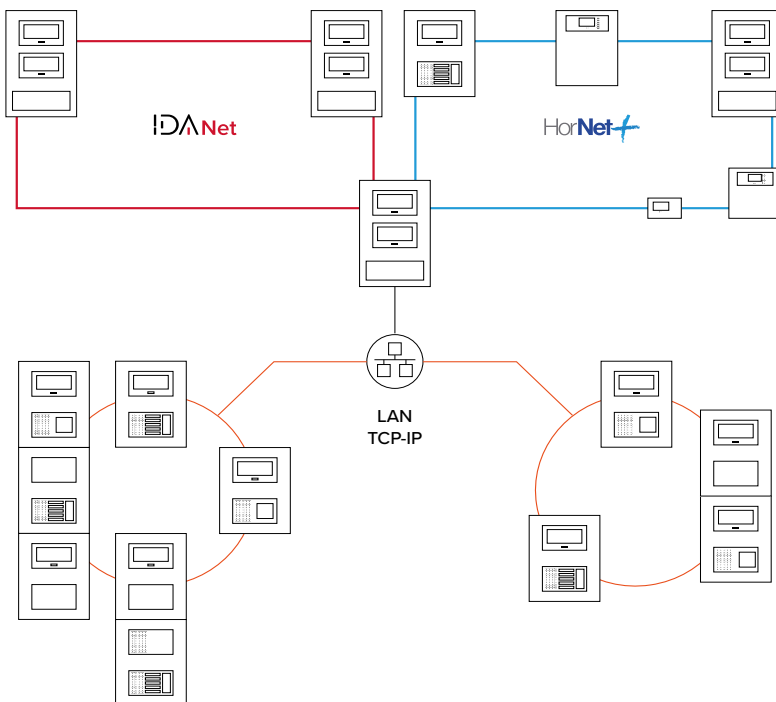



Audio management

Manages 8 local digital audio tracks and 8 digital audio tracks coming from the network, up to 30 class D 250W amplifiers.

Colour display

Dual 7" 65,000 colour touchscreen for integrated management of fire detection and alarm functions, GAS extinguishing, EVAC (Vocal Evacuation), Public Address (Sound broadcasting and audio entertainment).

1000 zones

Up to 1000 audio zones, causes and effects subordinate to the fire detection system, advanced management of audio entertainment (via IASS server and IAC APP).

Self-powered

1000 W power supply included expandable up to 4000 W (by adding PRCAB+ cabinet).

Internal memory

Internal Audio Memory for emergency and customizable messages, SD Card for additional audio, 2 Music inputs, 2 AUX inputs with priority acquisition via contact or on signal level.

Safe

Impedance control of the speaker lines by pilot tone, management of A/B lines, ring with optional isolators and reserve amplifier.

Expandable

Possibility of interconnecting up to a maximum of 4 cabinets, up to 32 IFM or IFAM internal modules and 8 FPM or FPAM frontal modules.

Certified

- Certification CPR / IMQ
- Certification EN54 pt2 / 4 /16 / 21 / 13
- Certification EN12094-1 (fire extinguishing systems) up to 24 channels





Previdia UltraVox

Basic control panel with fire detection and voice evacuation functions, to which the FPM, FPAM, IFM and IFAM function modules can be added. The cabinet, model PRCAB+, is complete with plastic front plate (door) and housing for the PTT microphone and optional emergency telephone.

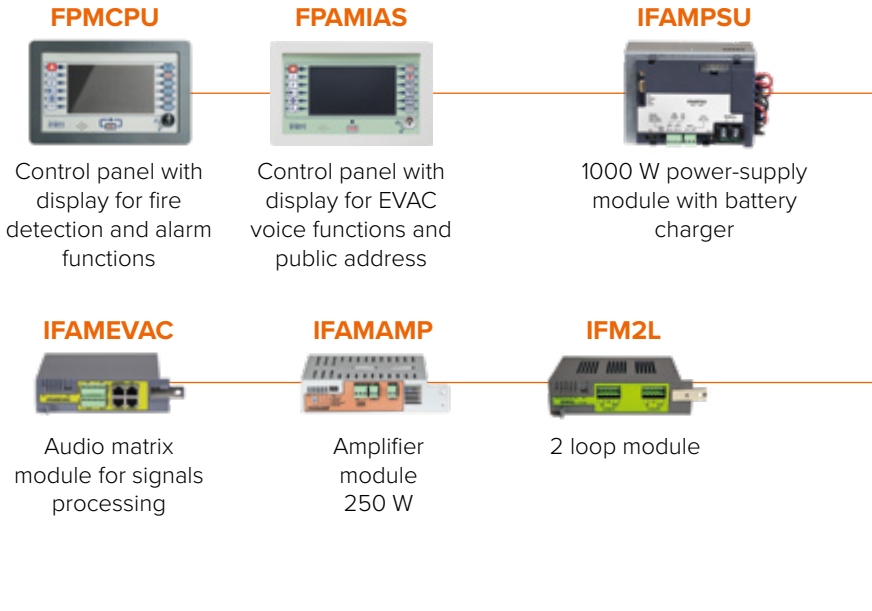

Previdia Ultra

Basic control panel with fire detection functions only to which the FPM, FPAM, IFM and IFAM function modules can be added. The cabinet, model PRCAB+, has no plastic front plate (door) or housing for the PTT microphone and emergency optional telephone.

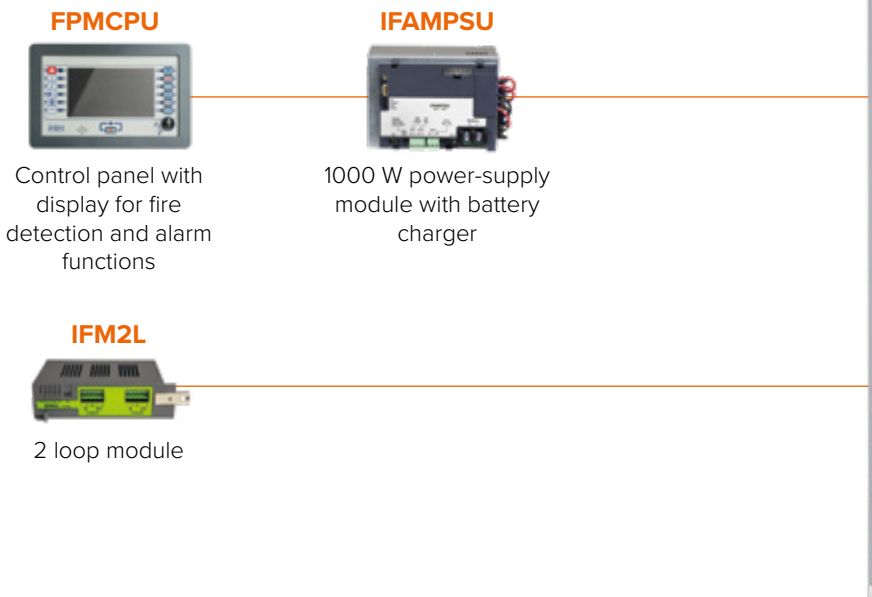

Previdia Vox

Basic control panel with only voice evacuation functions to which the FPM, FPAM, IFM and IFAM function modules can be added. The cabinet, model PRCAB+, is complete with plastic front plate (door) and housing for the PTT microphone and optional emergency telephone.

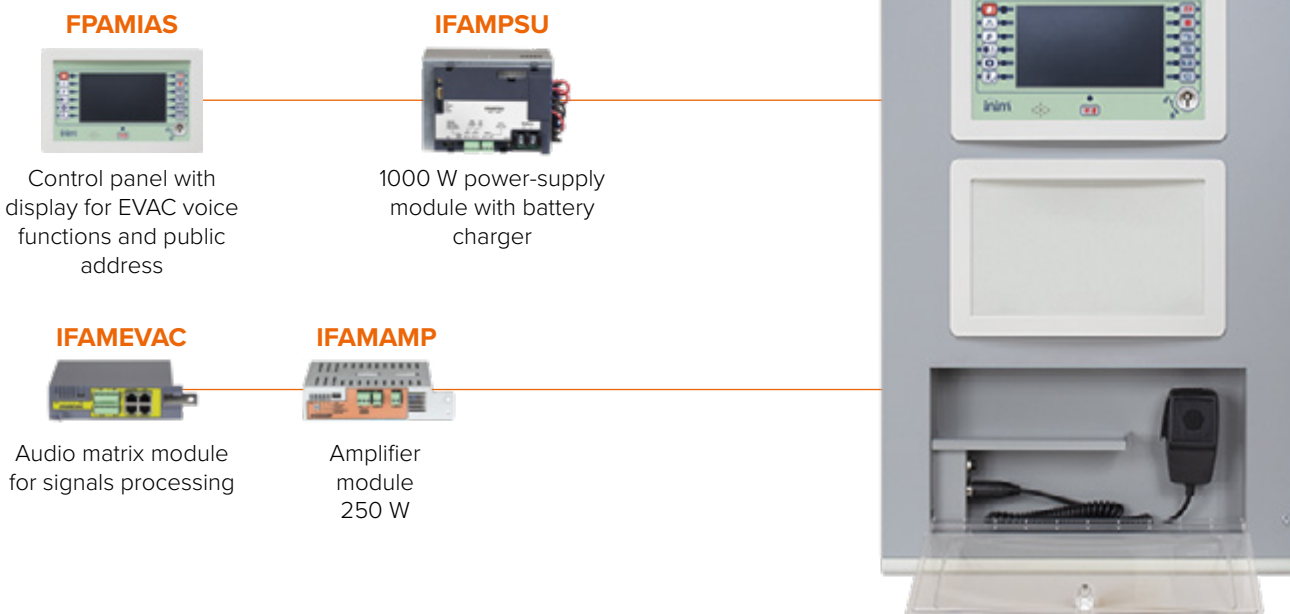

ORDER CODES	FIRE DETECTION	VOICE EVACUATION AND PUBLIC ADDRESSING	CABINET COLOUR	
			GREY	RED
Previdia-ULTRA	✓		✓	
Previdia-ULTRA-R	✓			✓
Previdia-VOX		✓	✓	
Previdia-VOX-R		✓		✓
Previdia-UltraVox	✓	✓	✓	
Previdia-UltraVox-R	✓	✓		✓

Previdia UltraVox control panel diagram

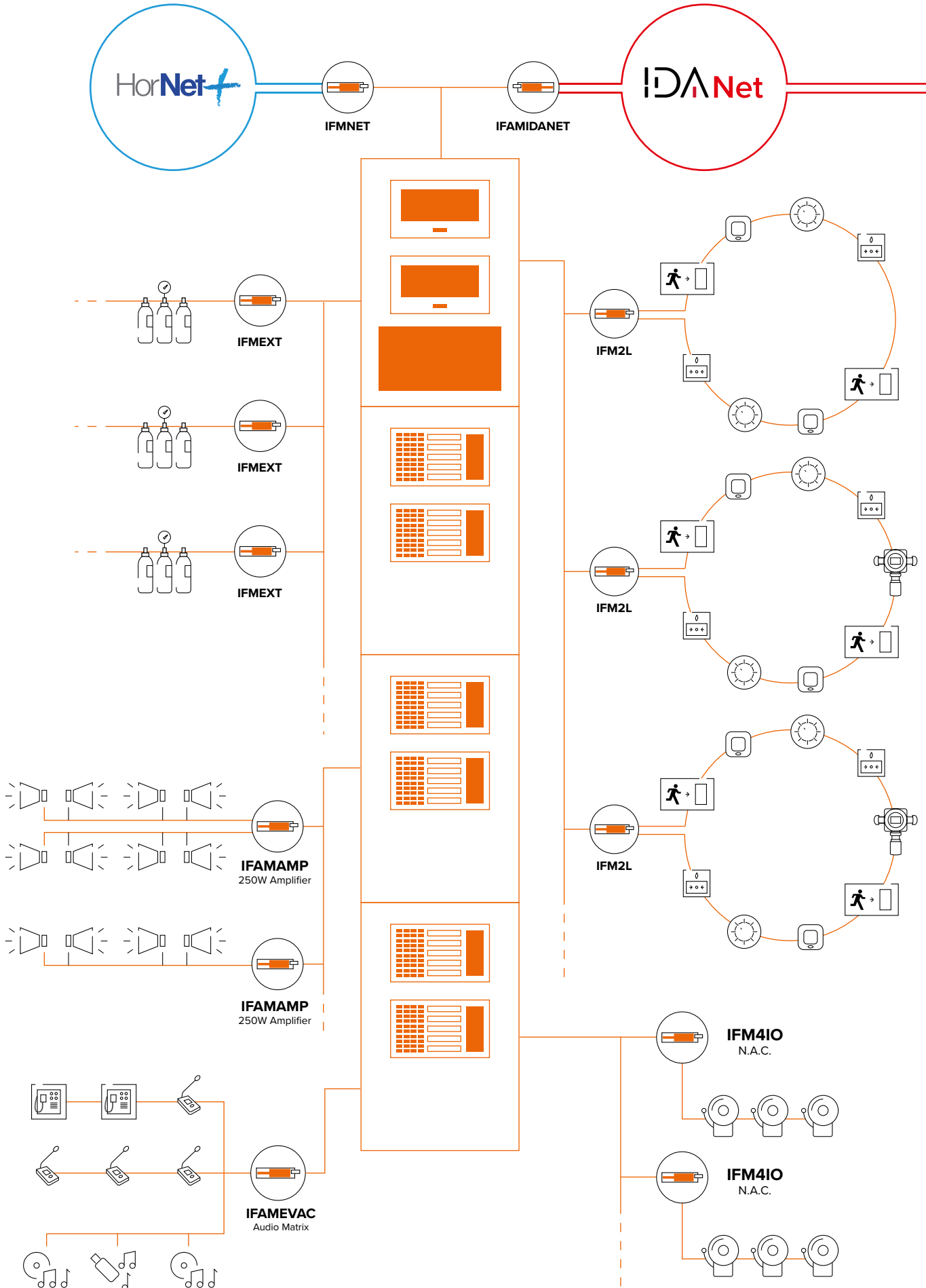

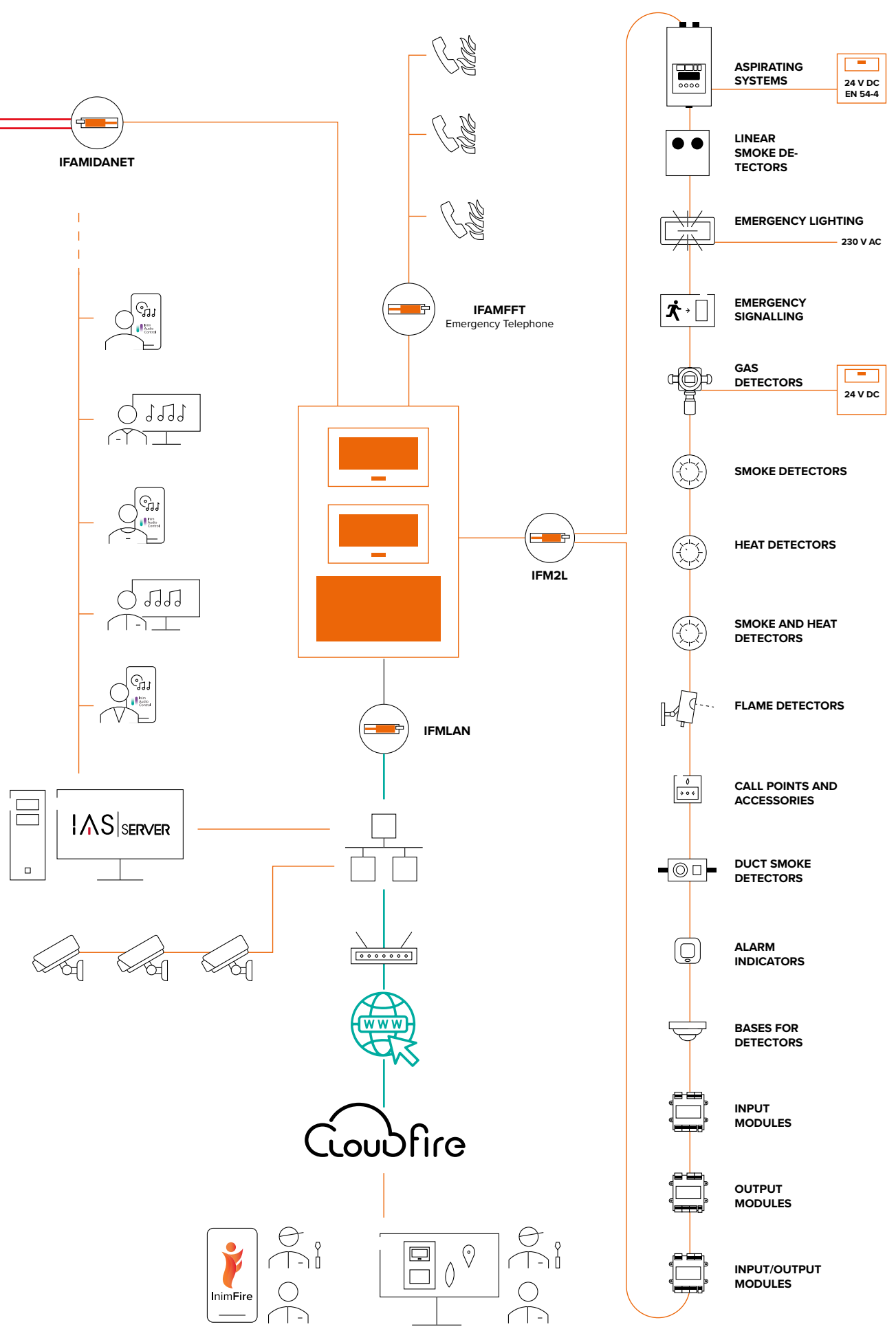



Accessories

These allow the expansion of the control panel (additional cabinets) or the creation of installations in accordance with cabling requirements.

PRCAB+

ADD-ON CABINET



Complete with door, CAN DRIVE+ bar for the connection of function modules, battery shelves. The door provides two apertures for two FPM modules (if certain functions are not required, two FPMNUL modules can be used to seal the apertures). The cabinet is supplied without the housing for the PTT microphone.

PRCABRK+R Red cabinet

TECHNICAL SPECIFICATIONS

Supported battery:	2 x 12 V 17 Ah	Dimensions:	675 x 430 x 260 mm
	2 x 12 V 24 Ah		
	2 x 12 V 38 Ah		
Protection grade:	IP30	Weight (without batteries):	10 Kg
		Cabinet colour:	Grey RAL7042 Red RAL3001

PRCABRK+

KIT FOR MOUNTING CABINET TO 19" RACK

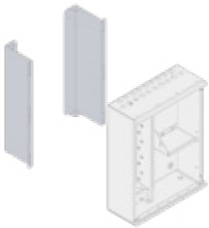

Bracket for fitting the PRCAB+ cabinet and Previdia-UltraVox control panels inside a 19" rack.

FPAM modules (Front Panel Audio Module)

Control panels from the Previdia UltraVox series, in addition to managing the FPM series front panel modules illustrated in the Previdia Max section, can also house the FPAM front panel modules with audio functions listed below. The modules from the FPM and FPAM series are housed on the cabinet front plate, maximum two per cabinet.

FPAMIAS

MAIN CONTROL UNIT FOR EVAC FUNCTIONS



Main control panel for voice EVAC functions. Mounts to the front plate and, if housed in the upper opening, connects to the CANDRIVE+ bar. If housed in the lower opening, it connects to the FPM module in the upper opening. Equipped with a graphic colour touch screen. It deals with the management and coordination of the various function modules assigned to it. A single Previdia UltraVox control panel can house only one of these modules.

- Ethernet connection for remote control
- Mini USB Port for configuration via PC
- Housing for the MicroSD-card
- Customization of user interface, icons, buttons etc.
- Connection with push-to-talk microphone and emergency telephone (optional) on the front panel
- Monitor speaker for listening to audio sources
- Status LEDs and function keys for evacuation management

TECHNICAL SPECIFICATIONS

Power supply voltage:	19÷30 V DC	Dimensions:	185 x 288 x 82 mm
Consumption @ 27.6V:	stand-by 110 mA	Weight:	900 g
Current draw in the event of main failure:	stand-by 60 mA	Package dimensions:	32.5 x 62 x 25 cm
Operating temperature:	-5° ... +40° C		

IFAM function modules

(Internal Fire Audio Module)

Previdia UltraVox control panels, in addition to housing the IFM internal modules described in the Previdia Max section, can house the IFAM internal modules with the audio functions listed below. IFM or IFAM series modules connect to the CANDRIVE+ bar on the inside of the cabinets (max. 8 IFM modules per cabinet) depending on the required functions.

IFAMPSU 1000W SWITCHING POWER SUPPLY MODULE



It connects to the mains power supply and supplies a maximum 38 Ah current to the system. Houses a 3 A battery charger capable of maintaining under charge two 17 Ah, 24 Ah or 38 Ah batteries. It has two supervised outputs and a configurable relay output (at factory default configured as Alarm output, AUX output and fault signalling relay). Only one power supply module can be housed inside each metal cabinet. Each control panel manages a maximum of 4 power supply modules (one for each eventual cabinet).

- CPU dedicated to the control of the module and communication with the control-panel FPMCPU module
- Control and monitoring of batteries
- Efficiency up to 94%

TECHNICAL SPECIFICATIONS

Power supply voltage:	90 ~ 264 V AC / 47 ~ 63 Hz
Maximum current draw:	8.5 A @ 115 V AC / 5A @ 230 V AC
Output voltage:	26 V DC nominal / +/- 10%
Ripple max:	200m Vp-p
Power factor:	0.95 @ 230 V AC / 0.99 @ 115 V AC at full load
Overvoltage protection:	105 ~ 135% of the declared potential
Overvoltage protection:	29 ~ 33 V
Overheating protection:	output voltage suspension, reactivation to reset temperature
Max. total current I _{max b} :	38 A
Max. current for battery charger:	3 A
Max. current destined for the I _{max a} system:	35 A
Max. current on each output (out1 and out 2):	1.5 A @ 27.6 V DC
Maximum current on relay:	5 A, 30 V DC
Consumption of batteries in the event of mains network failure:	30 mA

IFAMFFT MODULE FOR THE MANAGEMENT OF EMERGENCY TELEPHONES



Provides N°4 lines for the connection of emergency telephones (max 64 for each Line), lifting one of the telephones connected to the lines signals a chat request on the front panel, the chat request can be accepted via the display, it is possible to carry out a chat session with a maximum of 4 incoming calls. Each control panel manages up to 4 IFAMFFT modules.

- It can be plugged into the CANDRIVE+ bar of Previdia UltraVox cabinets
- Up to 64 emergency telephones in parallel for each line
- Max. 4 IFAMFFT module per control panel for a maximum of 16 emergency telephone lines
- Line connection via twisted pair cable

TECHNICAL SPECIFICATIONS

Power supply voltage:	20-30 V DC (powered by the CANDRIVE+ bar)
Maximum current draw:	80 mA



IFAMAMP

250W AUDIO AMPLIFIER MODULE



It provides two lines for connecting speakers configurable in A/B mode or in loop mode, each line is protected separately against short circuit. The impedance of the speaker line is supervised by a high frequency tone. Includes an analogue input for an audio source with adjustable priority for the amplifier line only. Automatic management of any backup amplifier included in the cabinet. Each control panel manages a maximum of 30 IFAMAMP modules (maximum 8 for each cabinet).

- Class D amplifier
- Configurable as a loop connection (IAS-ISOL1000 isolator modules are to be added to the loop)
- Can be configured as a backup power-supply
- Local audio input with configurable priority for audio sources intended for the amplifier speaker line only
- Hot arming/disarming on the CANDRIVE+ bar
- Volume and 3-band equalization separately adjustable for sources such as music, voice announcements, emergency

TECHNICAL SPECIFICATIONS

Power supply voltage:	20-30 V Dc (powered by the CANDRIVE+ bar)
Maximum current draw:	530 mA (14 W)
Absorption in the event of mains power failure:	100 mA (2.5 W) max.
Max. current draw:	3 A (250 W + 14 W)
Speaker output voltage (Line A / Line B):	100 Vrms max.
Maximum load on speaker lines (Line A / Line B):	250 W max. total - minimum load 40 Ω total
Vin local audio input:	Max. 1 Vrms (UNBALANCED – BETWEEN + and GND or BEETWEEN – and GND)
Local audio input impedance:	10 kΩ
Frequency response:	60 - 20000 Hz
Separate volume adjustment for sources: Music / voice announcements / emergency:	+10 / -40 dB
Separate 3-band equalization for sources: Music / voice announcements / emergency:	+6 / -40 dB

IFAMIDANET

MODULE FOR THE CONNECTION IN IDANET NETWORK



Provides two RJ45 sockets for the connection via CAT5 Ethernet cable (for distances up to 100m) and two sockets for housing SFP modules for the fiber optic connection. **Attention the SFP modules must be of the type SFP - 100 BASE - FX.** It allows the connection of up to 48 control panels and can share, along with all the system information, up to a maximum of 20 audio tracks.

- Ring connection (Token Ring)
- Automatic network configuration
- Complete sharing of information with control panels
- Automatic priority management of shared audio tracks
- Hot arming/disarming (HOT SWAP)
- Max. one IFAMIDANET module per control panel

TECHNICAL SPECIFICATIONS

Power supply voltage:	20 - 30 V Dc (powered by the CANDRIVE+ bar)
Maximum current draw:	80 mA
Max current draw with fiber connections:	80 mA + consumption SFP modules (@ 3.3 V) divided by 7 (typically about 15 mA x each converter)

IFAMEVAC

AUDIO MATRIX MODULE



Manages the digital processing of all audio sources, and has:

- 2 analog inputs for external sound sources (MUSIC1 and MUSIC 2)
- 2 analogue inputs for external sound sources (AUX1 and AUX2) with priority enrollment via the “pr” input or via signal level
- Internal flash memory with 4 minutes of audio. Pre-configured with emergency messages in different languages, customizable via configuration software
- SD card slot for user-defined audio files
- 2 lines for standard or emergency microphone bases (max 64 per line), connection to the Ethernet network for interaction with IASS and IAS-APP servers
- Hot arming/disarming (HOT SWAP)
- Ethernet/TCP-IP input for up/downloading of audio messages and connection with the IASS server
- RJ45 connector for connection with ptt microphone and emergency telephone, housed on the front panel of the control panel
- Volume adjustment and 3-band equalization of external audio sources

TECHNICAL SPECIFICATIONS

Power supply voltage:	20 - 30 V DC
Maximum current draw:	100 mA
MUSIC1, MUSIC2, AUX1, AUX2 Vin audio input:	Max. 1 Vrms (UNBALANCED – BETWEEN + and GND or BEETWEEN – and GND)
MUSIC1, MUSIC2, AUX1, AUX2 audio input impedance:	10 kΩ
PR AUX 1 AND AUX 2 inputs:	clean contact to GND
PAGER A / PAGER B line:	Max. 64 bases per line / max 1A per line / Max. 500m total per line

EDS-205A

5-PORT ETHERNET SWITCH



Industrial 5-port Ethernet switch hooks onto the DIN rail inside the Previdia Ultra control panel. Starting from a single Ethernet cable redistributes the connection to all the control panel modules.

TECHNICAL SPECIFICATIONS

Power supply voltage:	9.6 - 60 V DC
Maximum current draw:	0.09 A @ 24 V DC
No. Ports:	5



Microphone bases

They can be connected to the IFAMEVAC module via FTP CAT6 cable on the two dedicated lines. Available in standard or emergency models. Powered by the line (max 1 A) or by local power supply (IPS24024DT for standard bases or IPS24060 for emergency bases). Configurable buttons for selection of zone groups or recorded messages, with voice filter option.



IPG12

NON EMERGENCY BASE WITH 12 SELECTION BUTTONS

- 12 configurable buttons for selecting zones or groups of zones or recalling pre-recorded messages
- goosneck microphone (not supplied)
- Button to open audio with disengagement on release
- Button to open audio with hold until the next press
- Local power input (optional)
- Can be fitted into worktops



IPG24

NON EMERGENCY BASE WITH 24 SELECTION BUTTONS

- 24 configurable buttons for selecting zones or groups of zones or recalling pre-recorded messages
- Goosneck microphone (not supplied)
- Button to open audio with disengagement on release
- Button to open audio with hold until the next press
- Local power input (optional)
- Can be fitted into worktops



IPGE06

EMERGENCY BASE WITH 6 SELECTION BUTTONS



- 6 configurable buttons for selecting zones or groups of zones or recalling pre-recorded messages
- Alert, fault and bypass indicators for each zone
- Protected button for manual emergency activation
- Buttons and indicators for the activation of the staff-alert phase, warning and evacuation by zone
- Button for total arming or arming by single zone
- Button to mute messages
- Button to mute local signalling
- Local alert buzzer
- Can be housed in the IPGECAB cabinet;
- Can be used with GOOSENECK microphone (not supplied) for desktop solutions or with PTT microphone (not supplied) for application in the IPGECAB cabinet. Button to open audio with disengagement on release
- Button to open audio with hold until the next press
- Local power input (optional)
- Can be fitted into worktops



IPGE18

EMERGENCY BASE WITH 18 SELECTION BUTTONS



- 18 configurable buttons for selecting zones or groups of zones or recalling pre-recorded messages
- Alert, fault and bypass indicators for each zone
- Protected button for manual emergency activation
- Buttons and indicators for the activation of the staff-alert phase, warning and evacuation by zone
- Button for total arming or arming by single zone
- Button to mute messages
- Button to mute local signalling
- Local alert buzzer
- Can be housed in the IPGECAB cabinet;
- Can be used with GOOSENECK microphone (not supplied) for desktop solutions or with PTT microphone (not supplied) for application in the IPGECAB cabinet. Button to open audio with disengagement on release
- Button to open audio with hold until the next press
- Local power input (optional)
- Can be fitted into worktops

Accessories



FTLF1217P2BLT
SFP CONVERTERS FOR FIBER OPTIC CONNECTION

SFP module for IDANET fiber optic multimode connection, 200 Mb/S SX+ 1310 nm LC DDM MMF. Maximum point-to-point link distance: 2 Km.



IPG-GOOSENECK
FLEXIBLE GOOSENECK MICROPHONE STAND

For use with the microphone bases, with XLR connector.



IPG-PTT
PTT MICROPHONE

PTT microphone for use on the front panel or with microphone bases. 90° XLR connector



IPGECAB
METAL CABINET FOR EMERGENCY MICROPHONE BASES

With lock for the housing of emergency microphone stands models IPGE06 and IPGE18. Also provides housing for an optional IPS24060G model power supply. Provides housing for IPG-PTT microphone (not supplied).

- IPGECAB - S** Cabinet for IPGE06 emergency microphone stand, in grey
- IPGECAB - D** Cabinet for IPGE18 emergency microphone stand, in grey
- IPGECAB - SR** Cabinet for IPGE06 emergency microphone stand, in red
- IPGECAB - DR** Cabinet for IPGE18 emergency microphone stand, in red



IPS24024DT
24 V LOCAL POWER-SUPPLY FOR NON EMERGENCY MICROPHONE BASES.

24 V local power-supply for NON emergency microphone bases.



IFFT-PHONE
EMERGENCY TELEPHONE HANDSET

With 6.3 mm JACK connector Compatible with the front panel of Previdia UltraVox control panels or with the jack FFT-SOCKET.



IFFT-SOCKET
JACK SOCKET FOR EMERGENCY TELEPHONE CONNECTION

Jack socket for emergency telephone connection.

- IFFT-SOCKET** Jack socket, in white
- IFFT-SOCKETR** Jack socket, in red



IAS-EOL1000

SPEAKER EOL

EOL for speaker line, necessary only for speaker lines with total power below 20W. To be housed in the last speaker on the line.



IAS-ISOL1000

Isolator module for 100 V speaker line, to be used in the case of a ring configuration.



IAS-ADAPT100

Module for adapting and decoupling audio signals input into the Previdia UltraVox control panel (on analog inputs of the IFAMEVAC or IFAMAMP module). Input for 1 VRMS, 70 VRMS, 100 VRMS signals. Filter for the 20 KHZ included.



PRCAB-BOOSTFAN

Booster cooling fan for cabinets. Recommended for use in cabinets with more than three amplifiers (IFAMAMP) or in cabinets without a power supply unit (IFAMPSU). Only for control panels from the Previdia Ultra series (UltraVox, Ultra216, Vox).

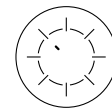

FIRE DETECTION



**ALARM
SIGNALLING**

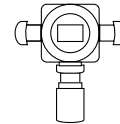

**GAS
DETECTION**



**EXTINGUISHMENT
CONTROL**

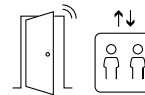

**BUILDING
CONTROL**

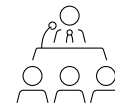

**PUBLIC
ADDRESS**

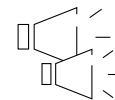

EVAC

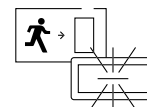

**EMERGENCY
LIGHTING**



**GRAPHIC
MAPS**

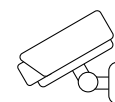

VIDEO VERIFICATION



**EMERGENCY
TELEPHONES
MANAGEMENT**



Inim Cloud Fire

See the
online
section



A universe of functions at your service

The WEB space accessible from any device that allows remote control of Fire Detection and Alarm Systems made up of Previdia series control panels (Previdia UltraVox, Previdia Max, Previdia Compact).

Via a browser or directly through the App it is possible to supervise and have total control of security systems at any time and from any place, so as to immediately verify the signalling of any emergencies or anomalies.

The customer management system organized in the Cloud platform facilitates the planning of maintenance sessions, so as to guarantee a highly professional and efficient service.

The digitized events and tests register of the fire control panels provides faster and more reliable verification of the operational capacity of the systems in compliance with the provisions of the norm. Inim Fire Cloud also updates the system and maintenance registers automatically thus ensuring that the systems operate in compliance with the provisions of current regulations.



Remote
monitoring
and control



Installation
registry and
maintenance



System
diagnostics



Interactive
graphic maps



Integrated video
verification

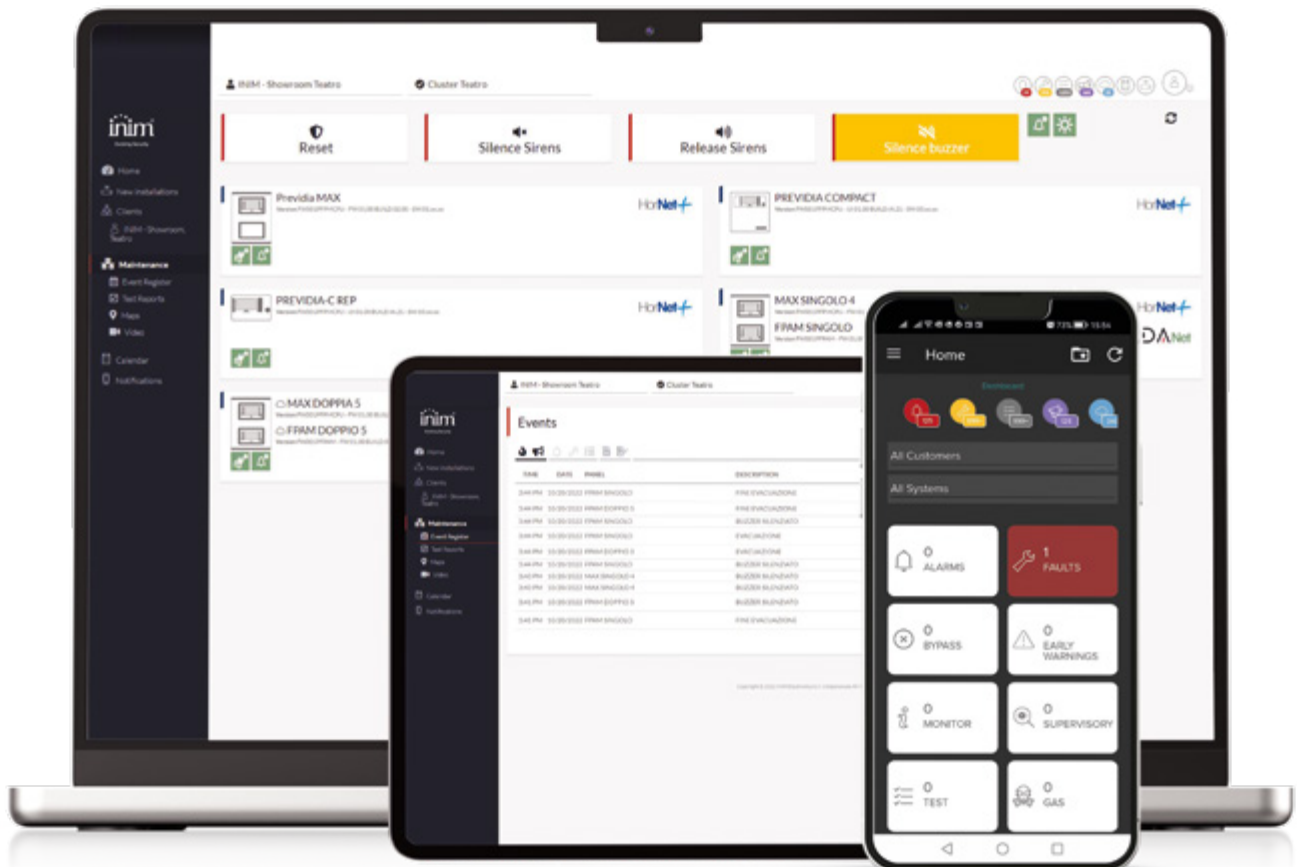



ADVANTAGES FOR THE INSTALLER

Provides the installer/maintenance technician with a tool to monitor their park of installations in an efficient and capillary way, makes available a customer management system to manage contacts, plan maintenance interventions and provide a professional and efficient service.

- Customer data registry
- Synoptic view of the events active on all the installed systems
- Assisted and guided system test
- Maintenance log with details of the tests performed on each point
- Diagnostic report with date of commissioning and last test, contamination values, anomalies for each point
- Interactive system log where it is possible to comment on each event or add reports
- Compilation of online maintenance reports as per current legislation
- Interactive graphic maps
- Video verification via any ONVIF camera on the site
- Calendar for planning technical interventions with interactive geolocation of the installation sites



ADVANTAGES FOR THE SAFETY MANAGER

Allows the security manager, via any browser or through the APP, to monitor and manage their systems and have total control at all times and from any location, as well as to note emergencies and anomalies immediately and thus take immediate action.

- Synoptic view of active events on all pertinent systems
- Interactive graphic maps for immediate location of the event
- Video verification via any ONVIF camera on the site
- Interactive system log where it is possible to comment on each event or add reports
- Verification of maintenance reports
- Diagnostic report on the operating and maintenance status of the system



ADVANTAGES FOR THE PURCHASER

Provides the operator with a means of verifying the detailed maintenance status, the correct management of alarm and fault events and the efficiency of the system. An indispensable means of ensuring that sites for which a person is legally responsible, in regard to the safety of occupants, are managed in a professional and competent way.

- Interactive system log where it is possible to comment on each event or add reports
- Verification of maintenance reports
- Diagnostic report on the operating and maintenance status of the system

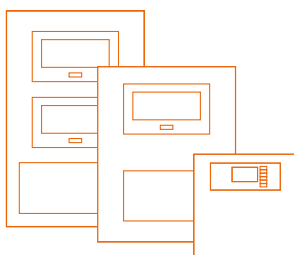

HOW TO REGISTER YOUR OWN PREVIDIA CONTROL PANEL ON THE CLOUD

The procedure is identical for each version of Previdia control panel (Compact, Max, UltraVox)

- 1a. Install the IFMLAN module (Max and Ultra)
- 1b. Connect the control panel to the Ethernet network
2. Register on inimcloud.com
3. Create your account and receive a unique code (installer ID).
5. Enter the code on a system keypad.
6. The control panel is connected to the Cloud.
7. Manage the system functions.
8. Store and view the documents on the system registers online.



Inim Fire App



The entire system managed via Smartphone

Free App, intended for professionals (installers and maintenance technicians) and end users (installation managers, security supervisors, etc.), allows management of all the Previdia series control panels connected to the Inim Fire Cloud.

Thanks to a simple and intuitive interface, provides a clear and immediate overview of the system, the tailor-made functions for each type of user make the Inim Fire App indispensable for safe, fast and professional management.

The App allows you to navigate amongst the various installations associated with your account and access the details of each individual control panel to the point of being able to supervise and manage every single zone, detector or device.



Download it
from Android
store



Download
it from
iOS store





NAVIGABLE TOPOGRAPHIC MAPS

Visualization is based on navigable multiple-level topographic maps that show interactive, customizable icons to provide instant awareness of the status of each zone, detector or element of the system. Possibility to select an icon and issue commands to the associated element as well as set up function keys for fast actions definable during the installation phase.



CAPTURING IMAGES FROM CAMERAS

Capable of showing on smartphones images captured by any IP camera installed on the site. Thanks to the management of the Onvif protocol, the control panels are able to communicate with any type of IP camera and, if necessary, pan, tilt and zoom it based on the location of the danger, returning a visual image for verification in real time of the extent and exactness of the danger reported.



AUTOMATED INSTALLATION REGISTER

The Inim Fire App allows viewing of both the events log and the “installations register” in which converge all the most significant automatically-recorded events (alarms, faults, bypass operations, etc.) and any events entered manually (maintenance operations, tests, fire drills, personnel training sessions, faults, etc.).

Each element in the ‘Installations registry’ can be commented on by a series of notes and closed with a virtual signature that permanently archives the event. The register can be printed out on paper and countersigned, allowing both the professional and the end user to promptly comply with the current obligations determined by law without any particular effort.



THE REVOLUTIONARY WALK TEST SYSTEM

Thanks to a revolutionary “walk test” function, once the zones to be tested have been selected, the Inim Fire App will show a list of the devices associated with them, with the possibility of turning on the location LEDs, testing detectors, inputs and outputs and automatically ticking the tested devices. An ingenious function that allows the professional to carry out periodic test operations quickly and without risk of forgetting even a single element.



REAL-TIME MAINTENANCE REPORT

At the end of each periodic test or maintenance session, the professional can compile and save the respective report to the Cloud in accordance with the provisions of the norm of reference. By downloading and filling in the forms available on the App, by loading any other compiled file or simple photo of the paper document, any document will be completed by Cloud adding the automatic registration of all the devices tested and entered in the installation register in compliance with legal obligations.



Inim Audio System Server (IASS)

A universe of functions at your service

The IASS server must be installed on a PC inside the same TCP-IP network of a Previdia UltraVox control panel and adds highly advanced “entertainment” audio functions to the system.

The server maintains a TCP-IP connection with on or more Previdia UltraVox control panels and, through access via web or APPs by an unlimited number of users, each with their own access rights, allows reproduction on the various audio zones of: an unlimited number of playlists consisting of audio files, TCP audio stream sources (such as web radio, etc.), audio tracks triggered by timers, voice announcements via smartphone... and much more.

All the functions made available by the revolutionary IASS server are obviously stopped when an emergency condition activates, in order to free up the system for the voice evacuation functions.

The IASS server is subject to license, the purchase code is

IASS_SERVER



See the
online
section

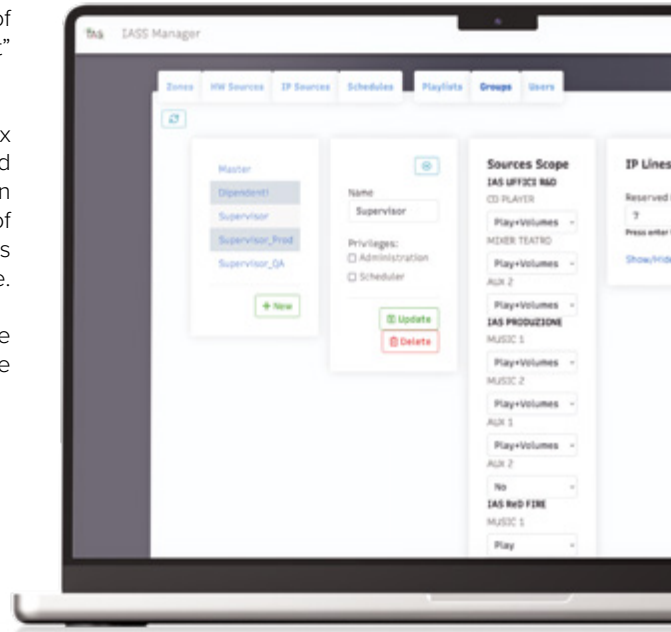

Inim Audio Control App (IAC)



Total Audio Control

IAC APP, in combination with the IASS server, allows operating activities on the audio zones pertaining to each user in order to: adjust volumes and equalizations, select and adjust the various physical sources available to the system, reproduce existing playlists or create new ones, reproduce TCP-IP streaming audio (web radio), send voice announcements from a Smartphone, activate pre-recorded messages, etc. The simple, intuitive user interface can be customized for each user thanks to the very convenient widgets that allow instant recall of the most frequently used functions.

The application can be downloaded free.



Download it
from Android
store

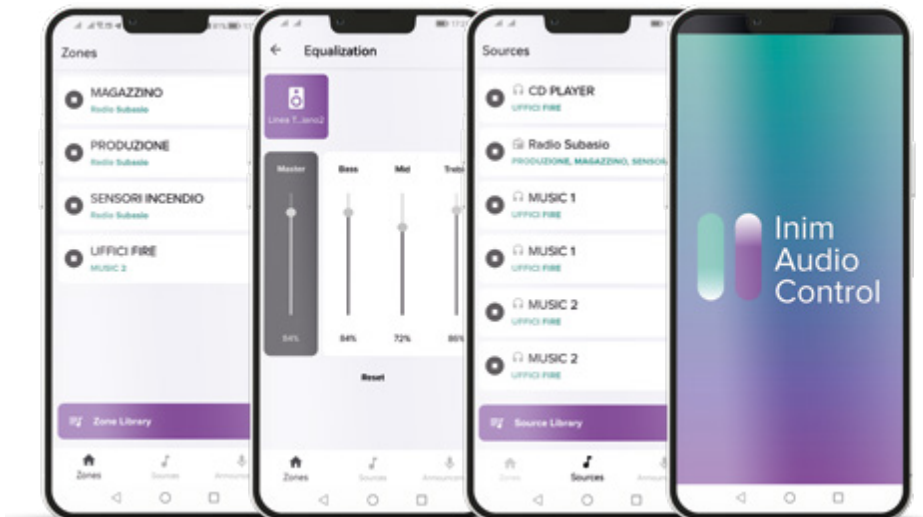

Download it
from
iOS store





Previdia/STUDIO



See the
online
section

Configuration and management software for Previdia control panels

A simple and intuitive tool essential for the commissioning and maintenance of the control panels, it allows quick and effective adjustment of the operating parameters of each single element of the system, the definition of the activation logics and the configuration of the various components.

Capable of operating both at individual control panel and network level, it makes use of a graphic interface designed to be used also on touch-screen devices. The software is completed with effective diagnostic functions that allow accurate fault searches and the adjustment of the various intervention thresholds.

Equally as effective are the reporting functions which allow, starting from the data automatically collected by the control panel, the creation of complete reports in compliance with current legislation. The software also manages a database that can collect and store the data of each completed installation including, for each customer, reports of all maintenance and tests carried out on the system. The Previdia/STUDIO software is capable of connecting to the system via RS232, USB, TCP/IP or Cloud connection, runs in Windows operating systems and can be downloaded free of charge by logging in and registering on website www.inim.biz.



BACnet

BACnet is a building-automation-network communication protocol developed by ASHRAE (American Society of Heating, Refrigeration and Air-Conditioning Engineers). BACnet, as a result of its versatility and flexibility, is now extensively used as a standard communication protocol between devices and building-automation systems made by various manufacturers. The BACnet protocol is implemented on the IFMLAN module for the Previdia Max control panels, its use is subject to licensing. Each license allows management of a specific number of points, by "point" we mean all those objects that can be supervised via the BACnet protocol: Loop Devices, Zones, Inputs, Outputs, etc. The licenses are not cumulative.

PRALICBAC500

Licence for the management of 500 points

PRALICBAC1000

Licence for the management of 1000 points

PRALICBAC1500

Licence for the management of 1500 points

PRALICBAC2000

Licence for the management of 2000 points



SmartLoop



Networkable analogue addressable fire alarm control panel with 1 loop expandable to 8

The SmartLoop platform includes control panels with 1 to 8 loops which can be connected in a network of up to 30 control panels. Considering that each control panel can manage up to 8 loops and that each loop can manage up to 240 devices, the enormity of installation solutions offered by the SmartLoop system is not difficult to imagine. The SmartLoop series has been designed to provide performance to the level of excellence coordinated by a 32-bit processor.



TECHNICAL SPECIFICATIONS

Power supply voltage:	230 V \sim (-15% / +10%) 50/60 Hz	Dimensions:	480 x 470 x 135 mm
Maximum internal power current:	4 A	Weight without battery:	8 Kg
Maximum external load current:	4 A		
Battery specifications:	2 x 12 V, 7 Ah ; 2 x 12 V, 17 Ah		
Operating temperature:	-5° ... +40° C		



See the
online
section



EN54 certified

Certified according to standards:

- EN54-2: Control panel and signalling devices
- EN54-4: Power supply units
- EN54-21: Remote communicators
- EN54-13: Compatibility of system components

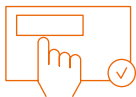

Simple installation

By operating on the alphanumeric display and on the frontal keypad, system commissioning and diagnostic functions can be carried out with ease.



Intuitive

The simple and essential structure makes it intuitive and effective for the end user.

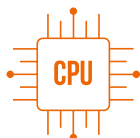

Emergency 54

Thanks to EMERGENCY 54 technology, the control panel is able to guarantee essential safety functions even in the event of main CPU failure, making it compliant with regulations even when more than 500 devices are connected to the control panel.



Connectable in Hornet network

As many as 30 SmartLoop control panels can be connected in a network thanks to the HORNET system (network different from the Hornet+ used in the Previdia system).



OpenLoop

Each control panel manages up to a maximum of 8 Loops of 240 devices each. Thanks to Open Loop technology, on each of them it is possible to choose Inim protocol, Argus or Apollo.

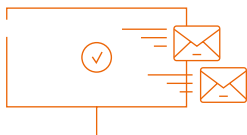

Janus

Janus technology (available on the SmartLAN module) allows the connection of the control panel to a TCP/IP network. In addition to the extended global reach of the system, Janus technology also allow you to send e-mails and UDP and TCP/IP protocol packets as well as allowing you to program all the control panels connected in the

network from remote locations.

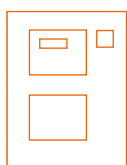

Flexible

A wide selection of accessory devices such as repeaters, on-panel printers, remote communicators, etc., makes it suitable for all applications.



SmartLoop control panel diagram

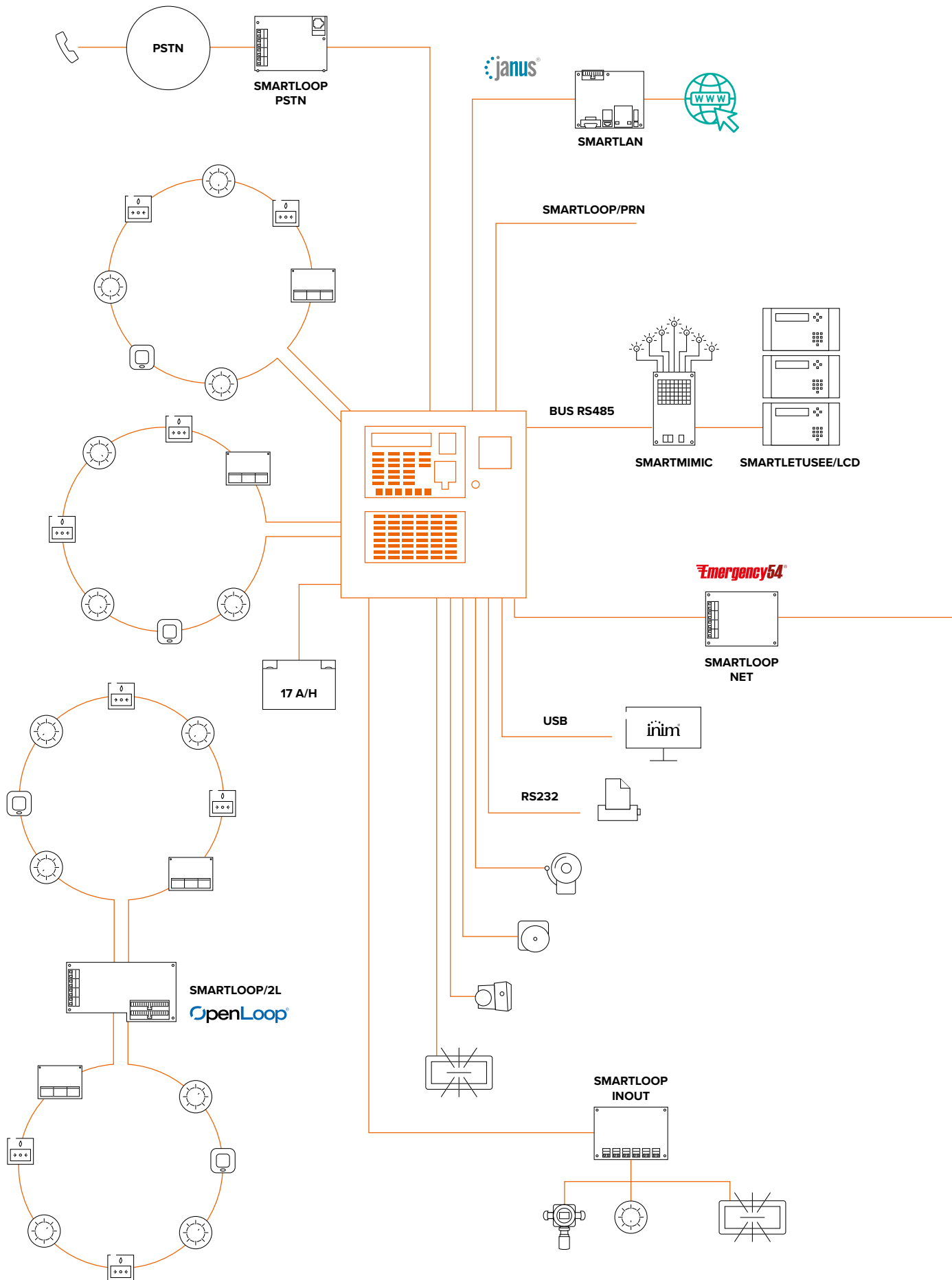

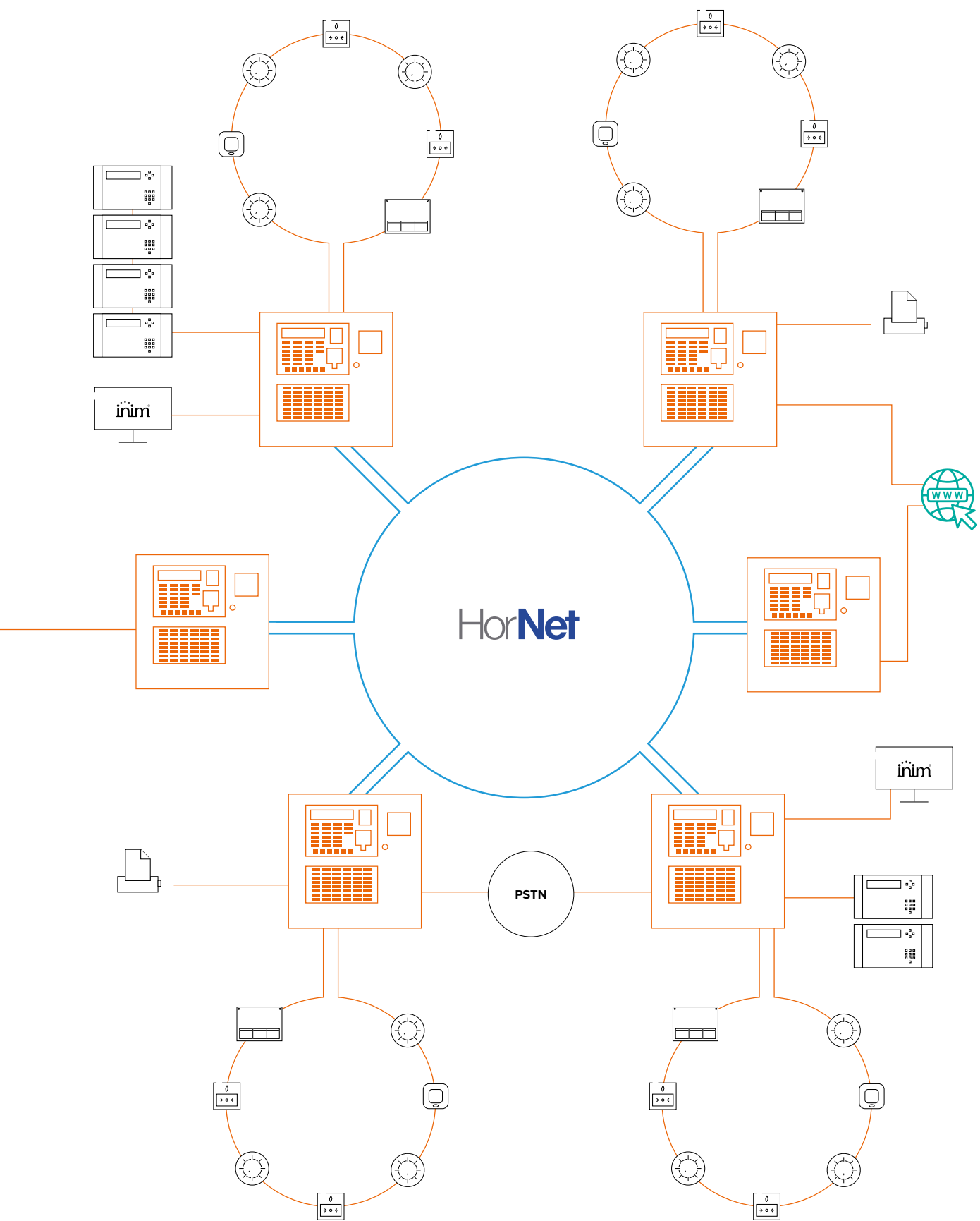



Intuitive

- Navigation keys for easy access to menu functions
- Fast access keys (test, buzzer, recognition, silence, reset, evacuate)
- Signalling buzzer
- Programming software runs in Windows environment
- Programming from the control panel

Events log

- Memory of the last 2000 events
- Self-enrolling of loop devices
- Self-addressing of loop devices

Always connected

Up to 30 control panels in the network using the SmartLoop/NET network board and easy remote access through SmartLAN board (accessory item)

Expandable

Analog-addressable control panel, 2 loops expandable to 8 for 2080 expandable models, 1 loop on non-expandable 1010 models, up to 240 devices per loop.

Flexible

- RS485 BUS for the connection of remote control panels (SmartLetUSee/LCD and SmartLetUSee/LED)
- Manages via RS485 BUS of the extinction control panel (SmartLine020-4EXT and SmartLine036-4EXT);
- Management over RS485 BUS of power-supply stations

Smart

Logic equations, activation triggers and structured cause-and-effect configuration.

Certified power-supply

- Metal enclosure
- Mains power supply 230 V AC \pm 10%
- Integrated power supply with switching-technology battery charger 4 A @ 27.6 V DC
- Battery housing for two 17 Ah, 12 V batteries

Inputs/Outputs

- 24V auxiliary power-supply output for external devices and 24V resettable ancillary power output
- RS232 and USB connectors for the connection of a PC
- 4 supervised outputs expandable to 10
- Alarm and fault relay

Emergency 54

Emergency CPU for compliance with EN54-2 requirements in the case of more than 500 connected devices.



ORDER CODES

Loop CAPACITY

DISPLAY

PRINTER

1 non-expandable Loop

2 loops expandable to 8

LCD command panel

LED visualization panel

Allocation for housing

	1 non-expandable Loop	2 loops expandable to 8	LCD command panel	LED visualization panel	Allocation for housing
SmartLoop1010/P	✓		✓	✓	✓
SmartLoop2080/P		✓	✓	✓	✓
SmartLoop1010/G	✓		✓		
SmartLoop2080/G		✓	✓		
SmartLoop1010/S	✓				
SmartLoop2080/S		✓			

Accessories connectable to RS485 BUS

SMARTLETUSEE/LCD

REMOTE CONTROL AND VISUALIZATION PANEL WITH LCD



Optional keypad equipped with LEDs, keys and display that replicates all the functions available via the control panel front plate. To be installed in places where it is necessary to view and check the status of the system. Each SmartLoop control panel manages up to 14 repeaters that can be connected up to a distance of 1000 m from the control panel. The connection with the control panel is established via the RS485 BUS present on the motherboard of the control panel.

SMARTLETUSEE/LED

REMOTE VISUALIZATION PANEL WITH LEDES



VISUALIZATION PANEL WITH LEDES The panel provides 48 freely-programmable LEDs capable of signalling conditions generated by the loop points, control panel zones or the system as a whole (alarms, pre-alarms, trouble, etc.). A label can be inserted for each LED. It connects to the remote SmartLetUSee/LCD control panel by means of a flat cable (included) and together they provide maximum system control and visualization capabilities.

SMARTMIMIC

SYNOPTIC PANEL BOARD



This board allows you to create a synoptic panel. All you need to do is attach a map (layout) of the protected premises to the front of any ordinary enclosure, perforate the map (layout) in the places where the zones are located, then wire up the LEDs using the wires supplied with the board. The board connects to the RS485 BUS port of the SmartLoop control panel and provides 48 connections for the LED wires.

SMARTLOOP/REL

12 RELAYS EXPANSION MODULE



It connects to the RS485 BUS of SmartLoop control panels to provide 12 configurable relays. Relays from 1 to 10 are capable of switching a maximum load of 30 V DC, 1A. Relays from 11 to 12 are capable of switching a maximum load of 240 V AC, 5 A.

SMARTLETUSEE/IP

IP REMOTE CONTROL SOFTWARE FOR SMARTLOOP PANELS



The SmartLetUSee IP software is an application that replicates the front plate of the SmartLoop control panel on the PC screen. Communication between the application and the control panel is achieved via TCP-IP protocol, therefore, the SmartLoop control panel must be equipped with a SmartLAN or SMartLAN/SF board and connected to an Ethernet network. The application replicates all the functions available on the front plate of the control panel, thus providing a repeater panel directly on a PC or Tablet.



Accessories connectable to the SmartLoop motherboard

SMARTLOOP/2L

OPENLOOP EXPANSION BOARD



Each expansion board adds 2 OpenLoop loops to the control panel thus offering the possibility to expand each control panel up to a maximum of 8 loops. Up to 3 loop expansion boards can be configured for each control panel. Being OpenLoop technology, each loop can be configured to work independently with one of the types of devices available. These boards can only be added to expandable models (2080 models).

TECHNICAL SPECIFICATIONS

Power supply voltage	19 / 30 V
Current draw	Stand-by: 20 mA MAX. 70 mA

SMARTLOOP/INOUT

INPUT AND OUTPUT EXPANSION BOARD

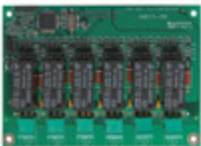

The SmartLoop/INOUT expansion board adds a further 6 terminals to the control panel. Each terminal can be set up to operate as either a supervised output NAC (1A max.); supervised input or input line (zone) for conventional detectors. The output trigger signals and the actions generated by the activation of the inputs are fully programmable.

TECHNICAL SPECIFICATIONS

Power supply voltage	19 / 30 V
Current draw	Stand-by: 40 mA Max. 300 mA

SMARTLOOP/NET

BOARD FOR THE CONNECTION OF SMARTLOOP CONTROL PANELS IN A HORNET NETWORK



The network can be made using 3-pole cable ring wiring. Each section (from control panel to control panel) can have a maximum length of 1000 m. The network created in this way provides a highly fault-tolerant network. Using a supplementary 2 pole cable (5 poles in all), it is possible to create a protection ring which can pass alarm conditions coming from a fire control panel with a microprocessor fault, through the ring thus ensuring maximum reliability (Emergency54 technology).

TECHNICAL SPECIFICATIONS

Power supply voltage	19 / 30 V
Current draw	Stand-by: 40 mA Max. 300 mA

SMARTLOOP/PSTN

LAND LINE DIGITAL AND VOICE DIALLER BOARD



It allows the fire control panel to communicate over the land line (PSTN). It manages (and monitors) 2 lines and uses the most widely used reporting protocols (SIA, Contact ID, etc.). The board has an 8 slot audio memory for up to 8 voice-call messages. The two phone lines are monitored and guarantee signalling in the event of line down faults. Completely managed by its own microcontroller, it guarantees an emergency call in the event of a control panel microprocessor fault. The emergency call is also guaranteed if an alarm occurs when the control panel microcontroller is faulty (Emergency54 technology).

TECHNICAL SPECIFICATIONS

Power supply voltage	19 / 30 V
Current draw	Stand-by: 20 mA Max. 60 mA



SMARTLAN

WEB SERVER AND ETHERNET INTERFACE FOR REMOTE PROGRAMMING AND CONTROL



The SmartLoop/LAN board connects to any Ethernet network and allows remote access (via Internet) to the fire control system (allows connection to all the fire control panels in the token-ring network). The board is capable of sending detailed e-mails for each event and real-time event reports via TCP/IP. The board also provides the possibility to carry out remote programming (up-downloading) of data, of managing the system via the SmartLook control software, as well as providing a web server which allows access to the control panel via the Web.

TECHNICAL SPECIFICATIONS

Power supply voltage	19 / 30 V
Current draw	Stand-by: 200 mA Max. 300 mA

SMARTLAN/SF

ETHERNET INTERFACE FOR REMOTE PROGRAMMING



The SmartLAN/SF board connects to any Ethernet network and allows remote access (via Internet) to the control panel and to all control panels present in the HorNet network. The board provides the possibility to carry out remote programming (up-downloading) of data and of managing the system via the SmartLook control software. Supports Modus over TCP/IP

TECHNICAL SPECIFICATIONS

Power supply voltage	19 / 30 V
Current draw	Stand-by: 40 mA Max. 40 mA

SMARTLOOP/PRN

ON-PANEL PRINTER MODULE



The SmartLoop/PRN thermal printer module mounts to the front of the control panel and connects directly to the motherboard by means of a connection cable (included). It uses 56mm thermal roll paper. The SmartLoop/PRN allows real-time printing of events or on-demand printing of portions of the control panel event log. It can also printout complete loop reports containing information about dust accumulation and detector functionality. The SmartLoop/PRN can be mounted to SmartLoop1010P and SmartLoop2080P models only.

TECHNICAL SPECIFICATIONS

Power supply voltage	19 / 30 V
Current draw	Stand-by: 0 mA Max. 1 mA

OPTIONS PROVIDED

OPTIONAL ATTACHMENT BOARDS

CONTROL PANEL MODELS	OPTIONS PROVIDED		OPTIONAL ATTACHMENT BOARDS					
	LCD panel	48 Status LED board	SmartLoop 2L	SmartLoop PRN	SmartLoop INOUT	SmartLoop NET	SmartLoop PSTN	SmartLAN SmartLAN/SF
SmartLoop/1010 - P	✓	✓		✓	✓	✓	✓	✓
SmartLoop/2080 - P	✓	✓	✓ (Max. 3)	✓	✓	✓	✓	✓
SmartLoop/1010 - G	✓				✓	✓	✓	✓
SmartLoop/2080 - G	✓		✓ (Max. 3)		✓	✓	✓	✓
SmartLoop/1010 - S					✓	✓	✓	✓
SmartLoop/2080 - S			✓ (Max. 3)		✓	✓	✓	✓



SmartLight



Single loop analogue-addressable fire detection control panel

The compactness, simple end-user operation, trouble-free installation and uncomplicated programming procedures make this highly competitive control panel ideal for small applications that require first rate performance. It is exactly this market segment that the SmartLight control panel finds its niche. It is perfect for those applications which require a limited number of detectors yet call for the reliability and performance that only analogue-addressable systems can provide.

With this application typology in mind, SmartLight is a valid alternative to conventional systems. The SmartLight control panel is based on OpenLoop technology. Thanks to the many protocols supported by its detection Loop, SmartLight is capable of managing a wide range of detectors and accessory devices and thus offers maximum flexibility and ease-of-use.



TECHNICAL SPECIFICATIONS

Power supply voltage:	230 V~ (-15% / +10%) 50/60 Hz	Dimensions:	325 x 325 x 80 mm
Maximum internal power current:	1.5 A	Weight without battery:	3 Kg
Maximum external load current:	1.5 A		
Battery specifications:	2 x 12 V, 7 Ah		
Operating temperature:	-5° ... +40° C		



See the
online
section



EN54 certified

Certified according to the standards:

EN54-2: Control panel and signalling devices

EN54-4: Power supply units

EN12094-1: Gas extinguishment-system

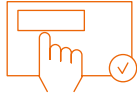

Simple installation

Alphanumeric display and keypad for the complete configuration via the frontal panel.



Intuitive

Alphanumeric display, keypad, key to pass to level level 2, signalling LEDs and integrated buzzer.



Manages extinguishing systems

Through the optional SmartLetLoose/ONE board it can manage a gas extinguishing channel, certified EN12094-1.

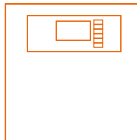

Compact

Its simplicity and its price-quality ratio make it unique in its market segment.





SmartLight control panel diagram

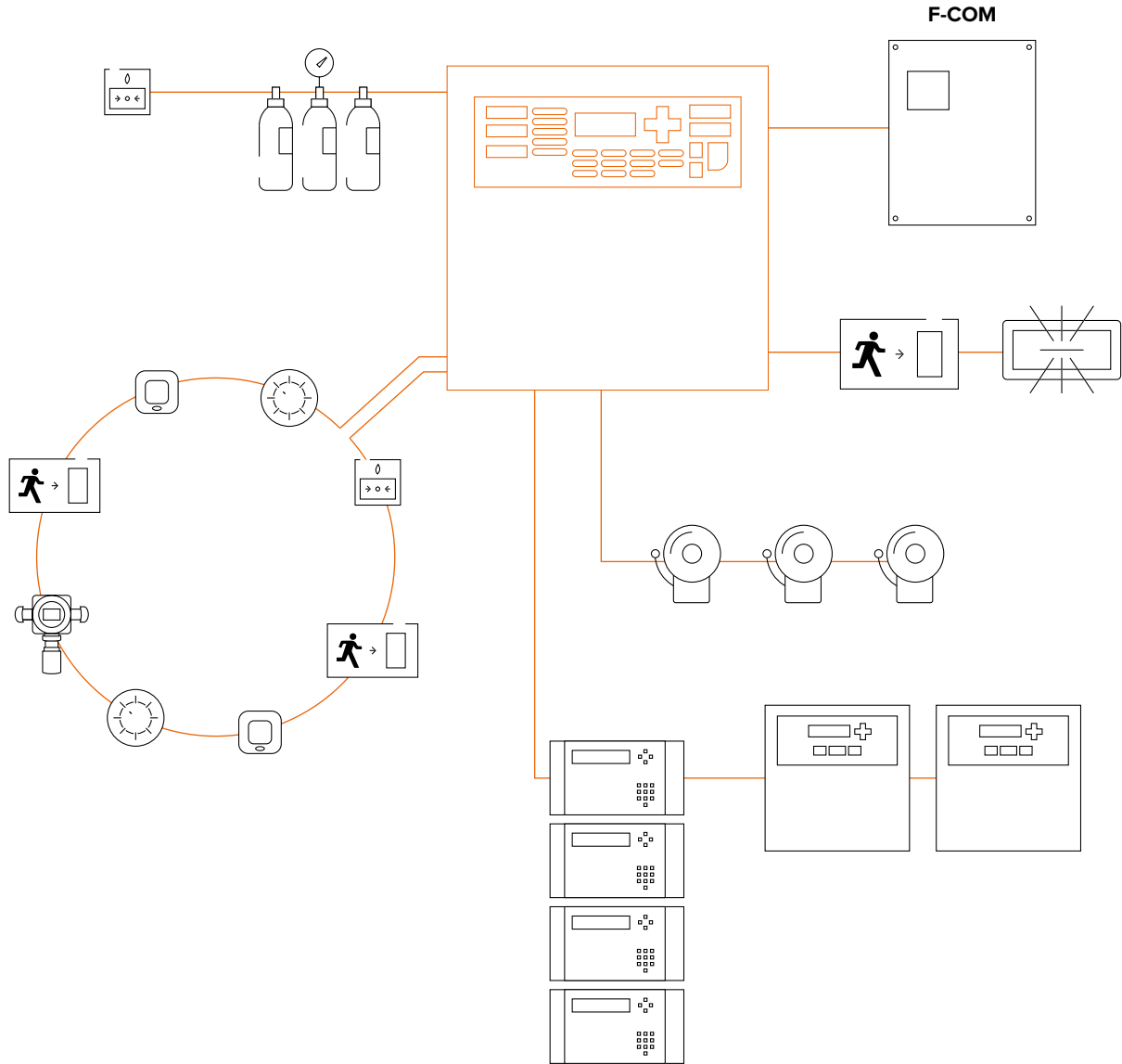

ORDER CODES	Loop CAPACITY	DEVICES	ZONES
SmartLight/S	✓	64	16
SmartLight/G	✓	240	30

Accessories for SmartLight

SMARTLETUSEE/LCD-LITE

REMOTE CONTROL AND VISUALIZATION PANEL WITH LCD.



Remote repeater panel equipped with LCD display and user-interface keypad (up to 4 for each control panel).

SMARTLETLOOSE/ONE

FIRE EXTINGUISHING BOARD



By equipping the control panel with this board provides a GAS extinguishing channel certified according to the EN12094-1 standard.

The control panel provides all the functions required by law and allows for the connection of the various accessories necessary for the management of an extinguishing system as shown below. (refer to “Accessory items for fire extinction systems”).

DIAGRAM KEY

- A Loop (zone A)
- B Loop (zone B)
- C SmartLight fire extinction control panel.
- D Extinguishing gas cylinders.
- E Gas release nozzles
- F Gas collectors
- G Pneumatic release valve
- H Pilot cylinder for gas release
- I Pilot cylinder electrovalve.
- L Pressure switch
- M Manual activation button
- N Stop extinction button
- O Audio/Visual signaller of imminent gas release
- P Audio/Visual signaller of gas present

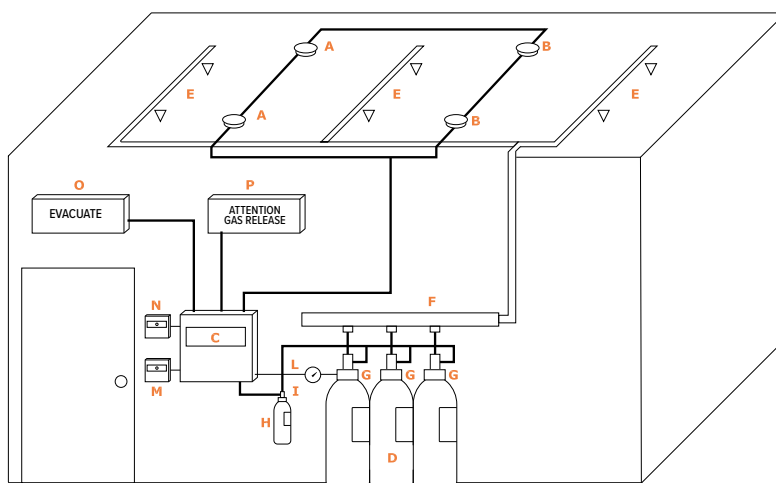

SmartLeague software

SOFTWARE FOR THE CONFIGURATION OF SMARTLOOP AND SMARTLIGHT CONTROL PANELS.

The SmartLeague programming and management software is intuitive and simple to use. This indispensable tool allows security professionals to control INIM fire detection systems with ease.

In addition to allowing fast configuration of the control panel parameters, it offers an overview of the system and provides wiring diagrams of the various terminals in function of the set options.





ED200

ED300

EC0020W

Analogue-addressable devices

Advanced systems for Loops

These connect to the control panels via a bipolar cable on which, in addition to the transfer of the supply voltage, two-way communication takes place permitting each device to transfer details regarding its status or on any detected measurements.

A speed dial system (interrupt) allows the devices to draw the attention of the control panel at the address thus minimizing response times.

The connection with the control panel is a ring connection (hence the name Loop) which guarantees tolerance to any wiring faults thanks to the short-circuit insulators contained inside each device.



Considerable savings on cables for loop connections



Creation of simple systems easily manageable locally



Two-way communication with the control panel

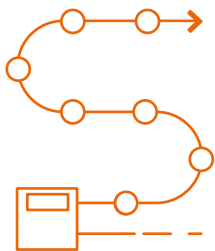

LoopMap technology

Once the loop is connected to the control panel or to the piloting device (EITK2000), the enrolling procedure starts on the PC and the interactive map of the loop and all its details are obtained.

The map includes any secondary branches, in the exact sequence in which the wiring was carried out, in order to simplify and speed up troubleshooting and system maintenance.



VERSA++

By means of the unique technology provided by Inim detectors it is possible to configure each detector according to the conditions of the specific environment in which it will be located.

By connecting to a line of detectors for each one it is possible to perform a complete diagnosis, test operation, check the value read in real time, read the contamination value of the optical chamber, modify sensitivity and operating mode.

Each detector has a non-volatile memory which allows you to view the smoke and temperature levels measured in the period prior to the last alarm detected.



Enea series detectors

Point fire detectors with advanced technology

Enea series detectors, as a result of advanced technologies based on new-generation microprocessors, represent the most advanced technology that fire detection equipment can offer today. They provide a vast spectrum of options and flexible functions, all configurable from the control panel (VERSA++ technology). Enea series detectors are capable of implementing a sophisticated set of algorithms, custom created by Inim's R&D professionals, which ensure unequalled reliability and the highest immunity to false alarms.

The detectors have brilliantly passed all the tests at the prestigious English institute LPCB and at the UL laboratories, obtaining both the certification which gives the right to use this mark and the CPR certification, a mandatory requirement for the commercialization of fire detectors.

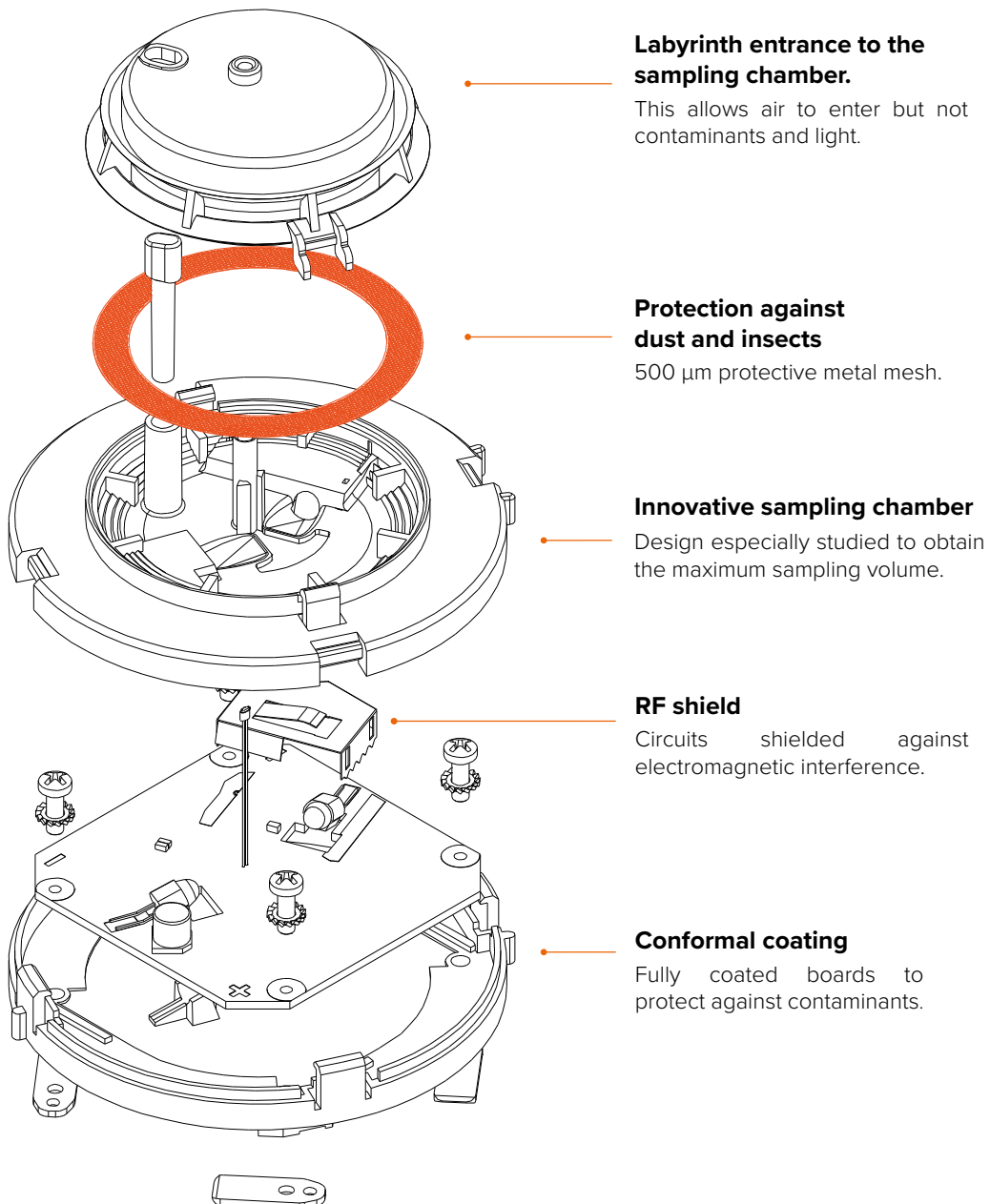



AND mode



OR mode



PLUS mode



See the online section

Built-in isolator

Integrated short-circuit isolator.

Innovative optical chamber

Upper-part of detector sealed, 500 µm metal mesh protection against entry of insects.

LED included, 3 colours

Red for alarm. Green for stand-by flashing (optional) and for localization by means of manual activation from the control panel. Yellow for fault (chamber contamination, short circuit isolator).

Complete diagnostics

Complete diagnostics: view the contamination level in the optical chamber and verify real-time values.

3 Operating mode

Operating mode selection (for ED300 version): only smoke, only temperature or smoke and temperature.

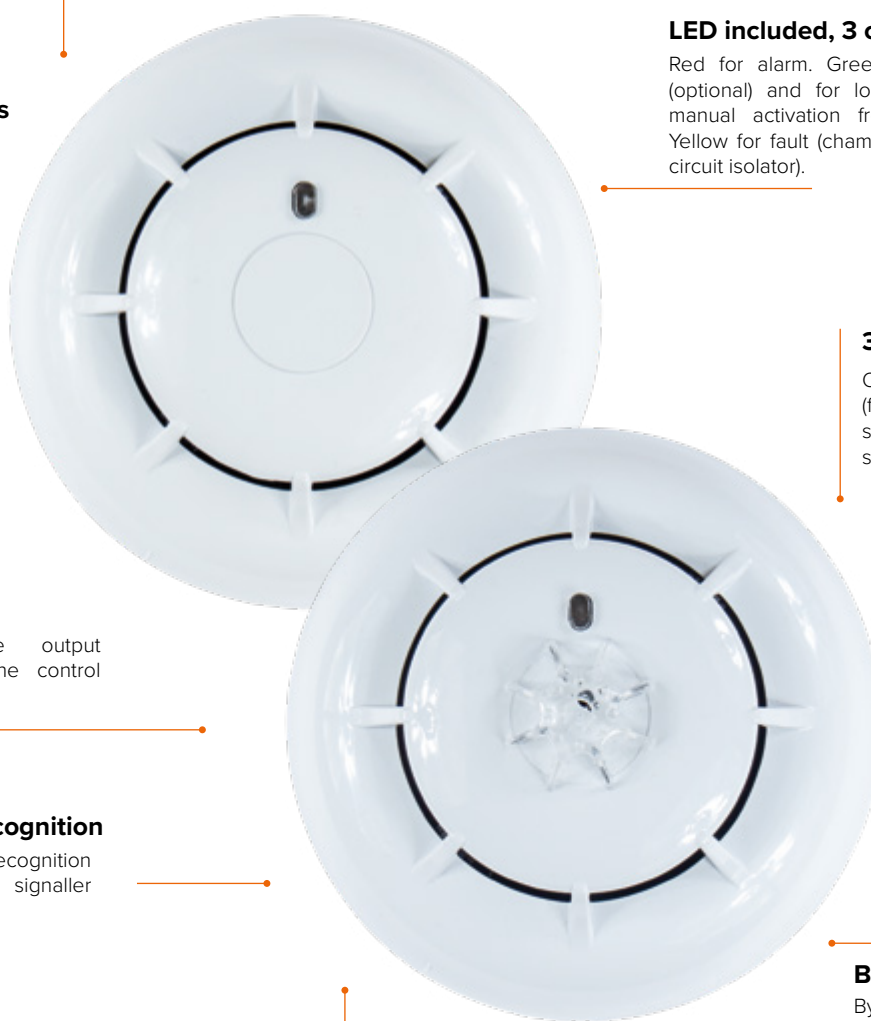

Supervised output

Supervised remote output configurable from the control panel.

Automatic recognition

Automatic recognition of remote signaller connection.

Auto-compensation

Drift compensation for sensor drift caused by dust in the chamber

Adjustable sensitivity

Settable smoke and heat detection sensitivity.

Bypass plate

Bypass plate on the base to give continuity to the line in the event of removal of a detector, possibility to test loop wiring continuity.



ED100
OPTIC SMOKE DETECTOR



The ID100 optical smoke detector is based on the Tyndall effect (diffusion of light) and provides first-rate early warning in the event of fire. It offers wide-spectrum detection of smoke particles generated by combustion. The newly designed optical chamber with sealed upper-part and 500 µm holes diameter mesh insect screen ensure high immunity to false alarms. Sensitivity can be modified to adapt the detector to different conditions of use (sensitivity that can be set: 0.08 dB/m - 0.10 dB/m - 0.12 dB/m - 0.15dB/m).

ED100/B Black version

ED200
HEAT DETECTOR



The detector can be set in the following modes: A1R (fixed threshold at 58°C with thermovelocimetric detection), B (fixed threshold at 72°C), A2S (fixed threshold at 58°C), BR (fixed threshold at 72°C with thermovelocimetric detection). As a result of its high flexibility, this detector is suitable for installation in dusty or smoky environments where the risk of false alarms is high.

ED200/B Black version

ED300
SMOKE AND HEAT DETECTOR

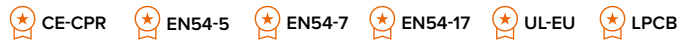

It combines the two systems to achieve increased sensitivity capable of detecting all types of fire outbreak (such as flammable liquid fires with low smoke output) and offers a very high false alarm rejection rate. The operating modes settable from the control panel are:

“PLUS” mode: The detector will trigger an alarm when the measured values exceed the set smoke threshold, or when the measured values exceed the set heat threshold. Furthermore, in the event of a rise in temperature, the smoke detection sensitivity will be taken to maximum value.

“OR” mode: The detector will trigger an alarm when the measured values exceed the set smoke threshold, or when the measured values exceed the set heat threshold. This operating mode, characterized by discrete sensitivity analysis, allows the detector to sense fires with a high emission of smoke and low heat output (for example, smouldering fires) and also fires with low emission of smoke and high heat output (for example, burning chemicals).

“AND” mode: The detector will trigger an alarm only when the set smoke and heat thresholds are exceeded at the same time. This operating mode, characterized by low sensitivity, greatly reduces the risk of false alarms. Given the reduced response, it is necessary to evaluate the risk factor before selecting this operating mode.

“SMOKE” mode: The detector will operate as per the ED100.

“HEAT” mode: The detector will operate as per the ED200.

ED300/B Black version

TECHNICAL SPECIFICATIONS

Power supply voltage:	19 - 30 V DC
Standby current consumption	200 µA
Alarm current consumption	Max 10 mA
Sensitivity that can be set:	A1R (58°C + RoR) - B (72°C) - BR (72°C + RoR) - A2S (58°C)
Operating temperature:	-5° ... +40° C
Height (base included):	54 mm
Diameter:	110 mm
Weight (with base):	160 g
Weight (without base):	90 g

Accessories for smoke and heat detectors



EB0010

Detector base for Iris and Enea series detectors, equipped with short-circuit plate which ensures continuity in the event of removal of the detector from the line.

EB0010/B Black version



EB0020

Detector base for Iris and Enea series detectors equipped with a relay activated by the detector.

EB0020/B Black version



EB0030

Mounting base for Enea and Iris detectors with pipes entry, 4 knock out for 16 mm pipes. To be installed under the detector base, h 34mm.



EB0040

Base protected against dripping water when tilted up to 15 degrees max.



EB0040H

2 W heater for EB0040 base



EB0050

EB0010 base spacer, to be installed under the base to create a 10 mm gap for the entry of exposed cables.

EB0050/B Black version



EB0060

Base for Iris and Enea detectors with integrated buzzer piloted by the 'R' output of the detector. Not compliant with EN54-3 standard.



DD001

This is a cover for unused detectors: it attaches to Inim detector bases, restores line continuity and provides a discrete aesthetic semblance.

Ideal for those applications where bases are installed for the future addition of detectors.



IL0010

Remote alarm signalling LED, directly connectable to the "R" output of addressable or analogue detectors.



EB0010SC

Cable shield connection for EB0010 bases (100 pieces)



Modules for addressable Loops

The interaction of the fire detection and alarm system with all the other building systems is essential for it to be effective in fighting a fire. For this reason, Inim offers a wide range of input/output modules for connection to the Loops of analogue addressable control panels which allow control and activation of external devices, monitoring of the status of appliances and the driving of signaling devices, etc.

EM312SR

INPUT AND OUTPUT MODULE

★ CE-CPR ★ EN54-17 ★ EN54-18 ★ LPCB



Connects to the Loop and has a supervised input (capable of controlling the status of an external device), a supervised output (capable of driving one or more audible or visual/audible signaling devices) and a free switching output (capable of driving all types of external devices, for example, electromagnets, etc).

- Built-in short-circuit isolator
- 3 multicolour LEDs for input/output/isolator status signalling
- Automatic addressing (each device is identified by an assigned serial number)

TECHNICAL SPECIFICATIONS

Power supply voltage:	19 - 30 V DC	Relay output:	Max. 1 A / 30 V
Current draw during standby:	80 µA	Supervised output:	Max. 1 A / 30 V
Current draw during alarm:	20 mA	Temperature:	-5 ... +40 °C
Resistance for input balancing:	22 KOhm	Dimensions:	53 x 100 x 29 mm
Resistance for alarm input:	2.2 KOhm	Weight:	66 g
Resistance for end-of-line supervised output:		22 KOhm	

EM110

INPUT MODULE

★ CE-CPR ★ EN54-17 ★ EN54-18



Connects directly to the loop and is equipped with a supervised input (capable of controlling the status of external devices).

- Built-in short-circuit isolator
- Tri-colour LED for input/isolator status signalling
- Automatic addressing (each device is identified by an assigned serial number)

TECHNICAL SPECIFICATIONS

Power supply voltage:	19 - 30 V DC	Relay output:	Max. 1 A / 30 V
Current draw during standby:	80 µA	Supervised output:	Max. 1 A / 30 V
Current draw during alarm:	20 mA	Temperature:	-5 ... +40 °C
Resistance for input balancing:	22 KOhm	Dimensions:	53 x 100 x 29 mm
Alarm input resistor:	2.2 KOhm	Weight:	66 g
End-of-line resistor supervised output	22 KOhm		

EM411R

CONVENTIONAL ZONE INTERFACE MODULE

★ CE-CPR ★ EN54-17 ★ EN54-18

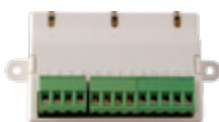

It connects to the Loop and allows a conventional line (max 32 devices) to be interfaced with Inim addressable analogue control panels.





- 1 conventional line input
- 1 relay output (2 voltage-free contacts)
- Built-in short-circuit isolator
- 3 multicolour LEDs for input/output/isolator status signalling
- Automatic addressing (each device is identified by an assigned serial number)

TECHNICAL SPECIFICATIONS

Power supply voltage:	19 - 30 V DC	Alarm threshold:	12 mA
Current draw during standby:	1.2 mA	Sort-circuit threshold:	50 Ohm
Current draw during alarm:	60 mA	Relay features:	Max. 1 A / 30 V
Conventional EOL: Condenser	22 µF 35 V	Temperature:	-10° ... +55° C
Tamper threshold without load:	220 nF	Dimensions:	53 x 100 x 29 mm
Tamper threshold with load:	220 nF	Weight:	66 g



EU311 MICROMODULE

 CE-CPR
  EN54-17
  EN54-18
  LPCB







Thanks to its reduced-size it can be housed directly inside the enclosure of the device it controls (call point, sounder/flasher, beam detector, etc.), it connects to the loop and has a supervised input (to control the status of a device) and an output powered directly by the Loop (to drive a signalling or audible/visual signalling device).

- EU311** Input/Output micromodule
- EU311C** Input only micromodule non-supervised for control of buttons for alarms, identifies on the Loop as a call point
- EU311CV** Supervised input only micromodule for control of buttons for allarms, identifies on the Loop as a call point
- EU311S** Output only micromodule for control of alarm signalling devices, identifies on the Loop as a sounder

TECHNICAL SPECIFICATIONS

Power supply voltage:	19 - 30 V DC	Temperature:	-5° ... +40° C
Current draw during standby:	80 µA	Dimensions:	53 x 100 x 29 mm
Current draw during alarm:	20 mA	Weight:	66 g
Resistance for input balancing:	22 KOhm		
Resistance for alarm input:	2.2 KOhm		
Resistance for end-of-line supervised output:	22 KOhm		

EM322AC MODULE WITH 2 INPUTS AND 2 RELAY OUTPUTS @ 230 V AC

 CE-CPR
  EN54-17
  EN54-18
  IMQ



It connects to the loop and has two supervised inputs (capable of controlling the status of an external device) and two relays capable of driving mains voltage loads at 230V AC. For each of the two output relays it is possible to enable a supervisory function that allows you to check whether there is voltage across the contact when the relay is in stand-by status.

- Built-in short-circuit isolator
- LEDs to indicate the status of inputs, outputs and communication with the control panel
- Automatic addressing (each device is identified by an assigned serial number)
- DIN rail mounting compatibility

TECHNICAL SPECIFICATIONS

Power supply voltage:	19 - 30 V DC	Temperature:	-5° ... +40° C
Current draw during standby:	80 µA	Dimensions:	113 x 71 x 43 mm
Current draw during alarm:	10 mA	Weight:	130 g
Resistance for input balancing:	22 KOhm		
Resistance for alarm input:	2.2 KOhm		
Relay features:	Max. 5A/30 V DC Max. 5A/230 V AC (with resistive load)		



EM3XX

MULTI INPUT/OUTPUT MODULE AND CONVENTIONAL LINE INTERFACE



CE-CPR



EN54-17



EN54-18



LPCB



The module connects to the loop and provides different inputs and outputs depending on the model (see table). In the versions equipped with 4 inputs, 2 of these can be configured as conventional zones or 4-20mA inputs, powered by the Loop or by a local power source. The 4 outputs are, depending on the model, supervised for the management of audible/visual signallers or dry contacts.

- Built-in short-circuit isolator
- Automatic addressing (each device is identified by an assigned serial number)
- Terminals for optional local power-supply

MODEL	INPUTS (SELECTABLE AS CONVENTIONAL ZONE)	OUTPUTS
EM344S	4 (2)	4 (supervised)
EM344R	4 (2)	4 (voltage free)
EM340	4 (2)	//
EM304S	//	4 (supervised)
EM304R	//	4 (voltage free)

TECHNICAL SPECIFICATIONS

Power supply voltage:	19 - 30 V DC	Resistance for supervised output:	22 KOhm
Current draw during standby:	80 µA	Output characteristics:	
		Single	Max. 1 A / 30 V
		Total on 4 outputs	Max. 2 A / 30 V
Current draw during alarm:	20 mA	Temperature:	-5° ... +40° C
Resistance for input balancing:	22 KOhm	Dimensions:	106 x 113 x 29 mm
Resistance for alarm input:	2.2 KOhm	Weight:	140 g

EM500

MODULE FOR THE CREATION OF SYNOPTIC PANELS



CE-CPR



EN54-17



EN54-18



The article consists of two separate units (both supplied):

EM500 module: Connects and is powered directly from the loop, provides 8 LED driver connectors (supplied) and 5 input terminals. Each of the 8 LEDs can be configured to activate in response to any condition, and each input can be used for any function.

EM500-EXP module: connects to the EM500 module via a cable (supplied) and adds a further 24 configurable LEDs, requires an auxiliary supply voltage (24V DC).

- Configurable buzzer
- LED with wire and connector included
- Built-in short-circuit isolator
- Automatic addressing (each device is identified by an assigned serial number)
- Compatible only with Previdia series control panels

TECHNICAL SPECIFICATIONS

Power supply voltage:	19 - 30 V DC	Temperature:	-5° ... +40° C
Current draw during standby:	200 µA	Dimensions:	83 x 53 mm
Current consumption with LEDs ON:	5 mA	Weight:	100 g
EXP module stand-by current consumption:	22 KOhm		
EXP module max. current consumption:	2.5 mA		

FBOX100

PLASTIC ENCLOSURE



IP65



For housing the EM312SR, EM110, EM411R, EM3xx, EM322AC model Loop modules.
Dimensions: 160 x 120 x 50 mm



Manual call points

A fire detection and alarm system must be equipped with devices for manual alarm activation installed along escape routes. Following is a series of addressable call points, connectable directly to the Loop.

EC0020

MANUAL CALL POINT

EN54-17 EN54-11 LPCB



Resettable call point, can be connected to the loop and managed by analogue-addressable fire control panels. The device trigger element and red status LED are located in the front of the device casing. After activation the call point can be reset by means of the reset key included in the package.

- Loop short circuit isolator included
- Transparent cover available for protection against accidental activation (WCP0020 item)
- Deep box available for exposed conduit entry (accessory DBCP0020y)
- Flange available for flush mounting on single gang boxes (accessory FCP0020)

TECHNICAL SPECIFICATIONS

Power supply voltage:	19 - 30 V DC	Temperature:	-10° ... +55° C
Current draw during standby:	80 µA	Dimensions:	84 x 84 x 45 mm
Current draw during alarm:	5 mA	Dimensions deep base:	33 mm
		Weight:	126 g

KCP0020

Reset key (pack of 10)

ALSO AVAILABLE IN THE FOLLOWING COLOURS (NOT CERTIFIED)

EC0020Y

Manual call point, yellow colour

EC0020B

Manual call point, blue colour

EC0020G

Manual call point, green colour

EC0020W

Manual call point, white colour

EC0011E

MANUAL CALL POINT FOR OUTDOOR USE

CE-CPR EN54-11 EN54-17 EN54-18 IP67



Manual call point for alarm activation for outdoor installations, includes a pre-assembled micromodule for loop connection, it is managed by Inim analogue-addressable fire control panels. After activation the call point can be reset by means of the reset key included in the package

KEY300

Reset key (pack of 10)

SFT304

Transparent protective cover

EM600 - HUSH BUTTON

HOME MUTE BUTTON

IMQ



It finds its ideal placement in residential installations and in applications where a control panel is installed for the protection of an entire apartment block with detectors inside each separate apartment.

By installing a call point inside each apartment, in the event of a smoke alarm a voice message will warn the occupants of only the apartment in danger. In the event of a false alarm, generated for instance by cooking, the occupants will have the possibility to silence the alarm, remove the cause and open a window for several minutes to ventilate the room. It is possible to silence an alarm three consecutive times after which the warning will be broadcast to the entire building. Clear and intuitive voice messages guide the building occupants throughout the various phases.

- Loop short circuit isolator included
- Messages in 8 different languages

TECHNICAL SPECIFICATIONS

Power supply voltage:	19 - 30 V DC	Temperature:	-10° ... +55° C
Current draw during standby:	100 µA	Dimensions:	812 x 95 x 31 mm
Current draw during alarm:	5 mA	Weight:	96 g



Addressable alarm indicators

A selection of audible, visual/audible signalling devices also with voice alarm functions connectable and manageable directly via the Loop of Inim control panels.

ES2000

VISUAL/AUDIBLE ALARM INDICATOR, WALL MOUNT



Volume, flash intensity and audio sequences selectable via the control panel (and diversified according to circumstances) selectable from the 14 tones (and 16 messages in 8 different languages for the versions with voice functions) available on board the device. For models with the voice alarm function, it is also possible to customize tones/voice messages by means of the EDRV2000. The device is powered via the loop but is equipped with terminals for an optional separate power input, built-in short-circuit isolator

- ES2011RE** Wall mount audible alarm signaller, in red
- ES2011WE** Wall mount audible alarm signaller, in white
- ES2021RE** Wall mount visual/audible alarm signaller, in red
- ES2021WE** Wall mount visual/audible alarm signaller, in white
- ES2030RE** Wall mount audible alarm signaller with voice messages, in red
- ES2030WE** Wall mount audible alarm signaller with voice messages, in white
- ES2050RE** Wall mount visual/audible alarm signaller with voice messages, in red
- ES2050WE** Wall mount visual/audible alarm signaller with voice messages, in white

TECHNICAL SPECIFICATIONS	ES2011 - ES2021	ES2030 - ES2050
Tone:	14 tones selectable via dip switch	14 tones + 16 voice messages selectable via EDRV2000
Sound output @ 1 m:	Max. 101 dB	
Visual range (EN54-23)	High power:	W 3.5-7 - 0-3.5-8-7
	Low power:	W 3-6.5 - 0-3-8-6.5
IP protection grade:	IP65 (certificated for indoor use)	
Operating voltage	18 - 30 V DC	
Current draw:	From 1.4 a 40 mA (depending on the selected tone)	
Operating temperature:	-10° ... +55° C	
Weight:	150 g	
Dimensions:	121 x 121 x 57 mm	

ESS021

ADDRESSABLE AUDIBLE-VISUAL WARNING SIGN



Red alarm sign complete with EN54-3 certified audible signalling. The ESS021 version is classified as a VID (Visual Indication Device) and is NOT certified for the visual part according to the EN54-23 standard. The ESS022 version is classified as a VAD (Visual Alarm Device) and includes an EN54-23 certified high power visual signaller. Comes with "Fire alarm" written on it, available with different indications on request.

ESS022 Audible-Visual alarm sign and flasher

TECHNICAL SPECIFICATIONS	ESS021	ESS022
Sound output @ 1 m:	92 dB (A)	
Light output (ENT4-23):	W 4.6 - 9.1	
Flash frequency:	1 Hz	
Operating voltage	18 - 30 V DC	
Current draw:	21 mA	50 mA
Operating temperature:	-10° ... +55° C	
Dimensions:	293 x 130 x 55 cm	

PLEXI_ES2000

PRE-SHAPED PLEXIGLASS PLATE WITH EMERGENCY INDICATION



To be combined with ES2000 indicators, with the wording “FIRE ALARM” (written in white on a red background) and the Inim logo. The panel is supplied with assembling kit and template. Dimensions: 430 x 130 x 4 mm.

PLEXI_ES2000#1DX	“ALLARME INCENDIO” warning sign with indicating RIGHT
PLEXI_ES2000#1SX	“ALLARME INCENDIO” warning sign with indicating LEFT
PLEXI_ES2000#2DX	“FIRE ALARM” warning sign with indicating RIGHT
PLEXI_ES2000#2SX	“FIRE ALARM” warning sign with indicating LEFT
PLEXI_ES2000#3DX	“EVACUARE IL LOCALE” warning sign with indicating RIGHT
PLEXI_ES2000#3SX	“EVACUARE IL LOCALE” warning sign with indicating LEFT
PLEXI_ES2000#4DX	“SPEGNIMENTO IN CORSO” warning sign with indicating RIGHT
PLEXI_ES2000#4SX	“SPEGNIMENTO IN CORSO” warning sign with indicating LEFT
PLEXI_ES2000#5DX	“ALLARME GAS” warning sign with indicating RIGHT
PLEXI_ES2000#5SX	“ALLARME GAS” warning sign with indicating LEFT

ESB1000

DETECTOR MOUNTING BASE WITH ALARM SIGNALLER



Base for Enea series detectors available in Audible, Visual/Audible versions, with or without voice alarm functions. Depending on the model, it is possible to select the alarm tone from the 14 available as well as adjust volume and flasher intensity (in models with flasher components). For models with the voice alarm function, besides the 14 tones, it is also possible to choose from the 16 voice messages available in 8 different languages and, via the EDRV2000, customize tones and voice messages. Loop-powered base.

NON-ADDRESSABLE VERSION

Activated by the “R” output of the detector, it does not occupy any address and cannot differentiate the tone/message in the event of a pre-alarm/alarm.

ISB1011	Non-addressable base with audible signalling
ISB1011B	Non-addressable base with audible signalling, in black
ISB1021	Non-addressable base with audible/visual signalling
ISB1021B	Non-addressable base with audible/visual signalling, in black
ISB1030	Non-addressable base with audible signalling and voice functions
ISB1030B	Non-addressable base with audible signalling and voice functions, in black
ISB1050	Non-addressable base with audible/visual signalling and voice functions
ISB1050B	Non-addressable base with audible/visual signalling and voice functions, in black

ADDRESSABLE VERSION

Occupies its own address and can be activated with different tones in the event of a Warning, Pre-alarm and Alarm, short-circuit isolator included.

ESB1011	Addressable base with audible signalling
ESB1011B	Addressable base with audible signalling, in black
ESB1021	Addressable base with audible/visual signalling
ESB1021B	Addressable base with audible/visual signalling, in black
ESB1020	Addressable base with audible/visual signalling with terminals for local power-supply.
ESB1020B	Addressable base with audible/visual signalling with terminals for local power-supply, in black
ESB1030	Addressable base with audible signalling and voice functions
ESB1030B	Addressable base with audible signalling and voice functions, in black
ESB1050	Addressable base with audible/visual signalling and voice functions
ESB1050B	Addressable base with audible/visual signalling and voice functions, in black



TECHNICAL SPECIFICATIONS		ESB1011 - ESB1021 ISB1011 - ISB1021	ESB1030 - ESB1050 ISB1030 - ISB1050
Tone:		14 tones selectable via dip switch	14 tones + 16 voice messages selectable via EDRV2000
Sound output @ 1 m:		Max. 98 dB	
Visual range (EN54-23)	High power:	C 3-8 - 0-3.3-8	C 3-10 - 0-4-10
	Low power:	C 3-7 - 0-3-7	C 3-9 - 0-3.5-9
IP protection grade:		IP21	
Operating voltage		18 - 30 V DC	
Current draw:		From 1.4 a 40 mA (depending on the selected tone)	
Optional separate power supply:		✓	
Operating temperature:		-10° ... +55° C	
Weight:		220 g	
Dimensions:		112 x 112 x 53 mm	

ES1000

CEILING MOUNT ALARM SIGNALLER



Addressable visual/audible-alarm indicator for ceiling mounting. Volume, flash intensity and audio sequences selectable via the control panel (and diversified according to circumstances) selectable from the 14 tones (and 16 messages in 8 different languages for the versions with voice functions) available on board the device. For models with the voice alarm function, it is also possible to customize tones/voice messages by means of the EDRV2000. Loop powered but equipped with terminals for optional separate power input in ES1030 and ES1050 versions.

- Available in Audible, Visual/Audible versions, with or without voice alarm functions
- Built-in short-circuit isolator
- Terminals for local power-supply optional for versions ES1020, ES1030, ES1050
- 14 tones selectable from the control panel (one for pre-alarm and one for alarm)
- 16 messages in 8 different languages for the versions with voice functions
- vocal messages and customizable tones via EDRV2000 programmer

- ES1011** Ceiling mount addressable audible signaller
- ES1021** Ceiling mount addressable visual/audible alarm signaller
- ES1020** Ceiling mount addressable visual/audible alarm signaller with terminals for power-supply
- ES1030** Ceiling mount addressable alarm signaller with voice functions
- ES1050** Ceiling mount addressable visual/audible alarm signaller with voice functions

TECHNICAL FEATURES		ES1011 - ES1021	ES1030 - ES1050
Tone:		14 selectable via Dip switch	14 - 16 voice messages selectable via EDRV2000
Sound output @ 1 m:		Max. 98 dB	
Visual range (EN54-23)	High power:	C 3-8 - 0-3.3-8	C 3-10 - 0-4-10
	Low power:	C 3-7 - 0-3-7	C 3-9 - 0-3.5-9
IP protection grade:		IP21	
Operating voltage		18 - 30 V DC	
Current draw:		From 1.4 a 40mA (depending on the selected tone)	
Operating temperature:		-10° ... +55° C	
Weight:		175 g	
Dimensions:		112 x 112 x 53 mm	

ES1000SP

SPACER FOR BASES WITH INTEGRATED SIGNALLER AND CEILING SIGNALLERS



1 cm spacer for ES1000 series ceiling-mount signallers and ESB1000 series bases with integrated signallers. For cable entry in installations where cabling is done using exposed cables. Packs of 10, also available in black.

- ES1000SPB** Spacer in black.

EITK2000-ToolKit



See the
online
section

Kit for manual addressing, configuration, maintenance and diagnostics of systems based on Iris and Enea series devices

EITK2000 is a kit containing:

- **EDRV2000 driver**
- **FireGenius-PRO software**
- **Accessories for the connection and power supply**

The EDRV2000 driver allows fast manual addressing of Enea series addressable-analogue devices in cases where the automatic addressing function provided by Inim control panels is not desired.

The driver is equipped with an “ICP” communication port through which it is possible to connect to fire alarm signalers from the Iris and Enea series and configure their operating parameters (select alarm tones/messages, volume, flasher power, etc.).

Through the driver and the FireGenius-PRO software, it is also possible to customize the tones/messages of the signalers by choosing from the large library available and composing tones to your liking or by starting from audio files.

The kit allows full advantage to be taken of the LoopMap and Versa++ technologies integrated in Enea series addressable analogue detectors. By connecting the EDRV2000 driver to the loop and interfacing it with the FireGenius-PRO software, it is possible to reconstruct the loop wiring map. The various devices connected to the loop are identified by their distinct serial numbers and types. The FireGenius-PRO software is capable of reconstructing the wiring order along the cable and to recognize and trace any ‘T’ junctions that are present. By clicking on the system elements, you will be able to establish the status (smoke level, contamination, etc.) and interact in real-time, for example, by activating LEDs or outputs.

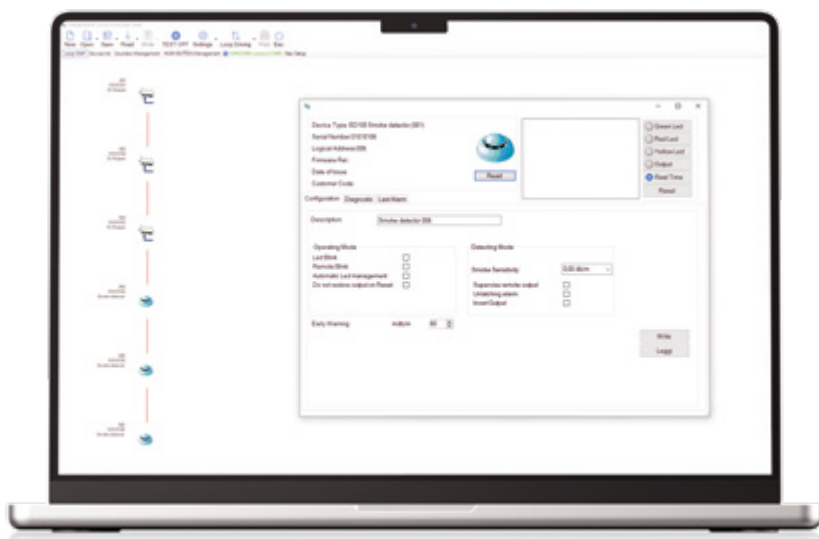



ILPS100 LOOP SIMULATOR



Connects to the Loop terminals of Inim control panels and simulates up to 240 devices, allows testing of loop functioning, verification of configuration and the cause/effect activation logics without having to physically connect the devices. Connects to a PC via the USB port (electrically decoupled so as not to interfere with the control panel and generate earth faults) and thanks to the "ILP Simulator" software it is possible to:

- Transfer to the ILPS100 device the configuration of a specific Loop extrapolated from a solution saved with the Previdia Studio software (simply export a solution to a file and open the file with the ILP Simulator software)
- View the loop activity, the software will show in real time how the control panel queries the various simulated devices
- Check the activation status of the simulated devices (the software will show the status of the outputs, LEDs and sounder-flashers in real time)
- Simulate a specific status on each of the devices (through the software it is possible, for each device, to activate the status of alarm, fault, warning, etc. or modify the analogue value)

The ILPS100 device, once configured, can be disconnected from the PC and left connected to the control panel to continue simulating the devices in the set mode.

To simulate several loops at the same time it is possible to use diverse ILPS100s managed by several instances of the ILP Simulator software running on the same PC.

ILP Simulator Software

The ILP Simulator software combines with the ILPS100 simulator

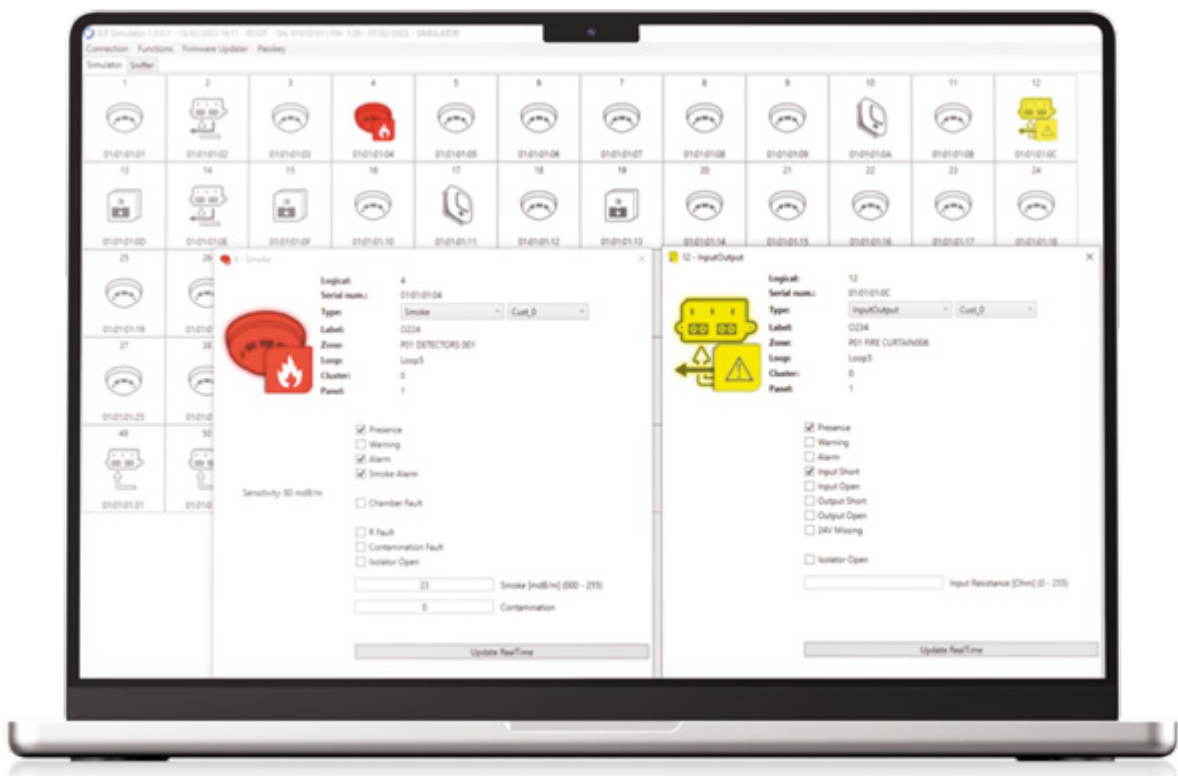



Argus Security devices

Third-party addressed analogue devices recognized by Inim control panels

Thanks to the OpenLoop technology, Inim addressable analogue control panels are compatible with third-party equipment as well as with Inim devices. This unique feature offers the professional a wide choice suitable for any installation.

Argus devices must be connected on dedicated Loops on which the Argus protocol must be set (software selection), devices with different protocols cannot coexist on the same loop.

A1000

ALTAIR SERIES ADDRESSABLE FIRE DETECTORS

CE-CPR EN54-17 EN54-5 EN54-7



Point smoke, heat and combined detector. The use of these devices requires an unlock code paired with each control panel supplied by Inim on request. Only Ax000 series devices can be addressed from the control panel (self-addressing) or by using the ALPU1000 hand-held programmer.

- A1000** Optical smoke detector
- A3500** Heat detector
- A2000** Smoke and Heat detector

TECHNICAL SPECIFICATIONS

Power supply voltage:	18 - 40 V DC	Height:	54 mm
Standby current consumption	70 µA	Diameter:	110 mm
Alarm current consumption	Max 20 mA	Weight:	130 g
Operating temperature:	-30° ... +70° C		

LAB1000

MOUNTING BASES FOR ALTAIR SERIES DETECTORS



The LAB1000 mounting base is compatible with all types of Altair Series analogue addressable Fire detectors. The device has connection terminals for the loop wiring and for the connection of the remote signaller. In the absence of an installed fire detector, the automatic spring connection maintains loop continuity thus allowing the wiring test. As soon as the detector is reassembled, proper operation with the loop isolators will be restored.



VMMI100

ADDRESSABLE INPUT/OUTPUT MODULES

★ CE-CPR ★ EN54-18 ★ EN54-17



Argus series modules allow status monitoring of external devices (input modules) or control of external devices or actuators (output modules). The modules include a short-circuit isolator and are available in Mini (96 x 52mm) or Wall (86 x 86mm) version

MINI-MODELS:

- VMMI100** Mini Module single supervised input
- VMMC100** Mini Module single supervised output
- VMMIC100** Mini Module supervised input/output
- VMMIC120** Mini Module voltage free input/output
- VMMC120** Mini Module unsupervised output

WALL-MOUNT MODELS:

- VMI100** Wall mount single supervised input module
- VMC100** Wall mount single supervised output module
- VMIC100** Wall mount supervised input/output module
- VMIC120** Wall mount voltage free input/output module
- VMC120** Wall mount unsupervised output module
- VMCZ100** Conventional zone interface module

TECHNICAL SPECIFICATIONS

Power supply voltage:	18 - 40 V DC	Mini-version dimensions:	75 x 52 x 28 mm
Standby current consumption	120 µA	Wall-mount version dimensions:	87 x 87 x 32 mm
Alarm current consumption	Max 6 mA	Weight:	200 gr
Operating temperature:	-30°C ... +70°C	Maximum wire section:	2.5 mm ²

ALCP100

ADDRESSABLE CALL POINT

★ CE-CPR ★ EN54-11 ★ EN54-17



The devices can be addressed from the control panel (self-addressing) or by using the ALPU1000 hand-held programmer.

- ALCP100** Addressable manual call point for indoor use
- AI-CPW-R-01** Addressable manual call point for outdoor use
- ALCI** Transparent plexiglass protection against accidental activations

TECHNICAL SPECIFICATIONS

Power supply voltage:	18 - 40 V DC
Standby current consumption	35 µA
Alarm current consumption	Max 20 mA
Operating temperature:	-30° ... +70° C

AI-BS-01

BASES FOR ALTAIR SERIES DETECTORS WITH ALARM SIGNALLERS

★ CE-CPR ★ EN54-3 ★ EN54-23



Bases with visual or visual/audible alarm signaller The signaller is activated by the remote output of the detector itself, the activation condition of which can be programmed in the control panel.

- AI-BS-01** Base with audible signaller
- AI-BSB-23W-01** Base with white light visual/audible signaller
- AI-BSB-23R-01** Base with red light visual/audible signaller

TECHNICAL SPECIFICATIONS

Power supply voltage:	18 - 40 V DC
Standby current consumption	120 µA
Operating temperature:	-10° ... +55° C

CWS100

VISUAL OR VISUAL-AUDIBLE WALL-MOUNT ALARM SIGNALLERS

CE-CPR
 EN54-17
 EN54-3
 EN54-23



Conventional wall-mount alarm signallers, with the addition of the ALWS-MOD module installed inside the signaller it is possible to connect and power the device directly via the loop.

CWS100	Conventional alarm signaller, in red
CWS100(W)	Conventional alarm signaller, in white
CWS100-AV	Visual-audible conventional alarm signaller, in red
CWS100-AV(W)	Visual-audible conventional alarm signaller, in white
ALWS-MOD	Module for the connection of signallers to Argus loops

TECHNICAL SPECIFICATIONS

Power supply voltage:	18 - 40 V DC
Standby current consumption	120 μ A
Operating temperature:	-10° ... +55° C

ALPU1000

ARGUS HAND-HELD PROGRAMMER



Configures the addresses of Argus series devices.

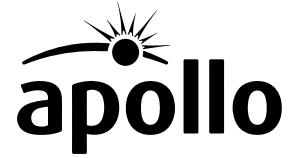

Apollo devices

Third-party addressable analogue devices recognized by Inim control panels

Thanks to the OpenLoop technology, the Inim addressable analogue control panels are compatible with third-party equipment as well as with the Inim devices. This unique feature offers the professional a wide choice suitable for every installation. Apollo devices must be connected on dedicated Loops on which the APOLLO protocol must be set (software selection), devices with different protocols cannot coexist on the same loop.

55000-620APO

XP95 SERIES ADDRESSABLE FIRE DETECTORS

CE-CPR EN54-5 EN54-7 EN54-17



Compatible with Inim control panels by setting the APOLLO protocol on the loop to which they are connected. Various classes of smoke, heat and combined smoke and heat detectors are available. The detectors DO NOT include the short-circuit insulator which has a separate code.

- 55000-620APO** XP95 addressable smoke detector
- 55000-420APO** XP95 addressable heat detector (class A2S)
- 55000-401APO** XP95 addressable heat detector (class CS)
- 55000-885APO** XP95 addressable smoke and heat detector
- 55000-660APO** XP95 addressable smoke detector, in black

58000-600APO

DISCOVERY SERIES ADDRESSABLE FIRE DETECTORS

CE-CPR EN54-5 EN54-7 EN54-17



Compatible with Inim control panels by setting the APOLLO protocol on the loop they are connected to. Smoke, heat, carbon monoxide or combined detectors are available, the sensitivities of which can be set from the control panel.

The detectors DO NOT include the short-circuit insulator which has a separate code.

- 58000-600APO** DISCOVERY addressable smoke detector
- 58000-400APO** DISCOVERY addressable heat detector
- 58000-300APO** DISCOVERY addressable CO detector
- 58000-700APO** DISCOVERY addressable smoke and heat detector
- 58000-305APO** DISCOVERY addressable CO and heat detector

45681-210APO

MOUNTING BASES FOR XP95 AND DISCOVERY SERIES DETECTORS



Compatible with both XP95 and DISCOVERY series detectors, available both in the standard version (with XPERT-CARD address selection included) and with isolator, deep version and black version.

- 45681-210APO** Mounting base for Apollo detectors
- 45681-361APO** Mounting base for Apollo detectors, in black
- 45681-284APO** Mounting base for Apollo detectors with short-circuit isolator
- 45681-209APO** Mounting base for Apollo detectors, deep (24 mm)
- 45681-211APO** Mounting base with short-circuit isolator (55000-720APO)



SHORT-CIRCUIT ISOLATOR

LOOP SHORT-CIRCUIT ISOLATOR

CE-CPR EN54-17



The Loop short-circuit isolator is capable of interrupting the continuity of the loop in the event of a short-circuit and of isolating the short-circuited section.

58100-910APO

APOLLO ADDRESSABLE CALL POINT

CE-CPR EN54-11 EN54-17



- 58100-910APO** DISCOVERY call point
- 58100-908APO** DISCOVERY call point with isolator
- 58200-950APO** DISCOVERY call point for outdoor use
- 58200-951APO** DISCOVERY call point with isolator for outdoor use
- 58100-927APO** DISCOVERY call point, in yellow
- 58100-953APO** DISCOVERY call point with isolator for outdoor use, in yellow
- 55100-905APO** XP95 call point
- 55100-908APO** XP95 call point with isolator
- SA5900-908APO** Intelligent series call point, in red
- SA5900-905APO** Intelligent series call point, in blue
- SA5900-906APO** Intelligent series call point, in green
- SA5900-907APO** Intelligent series call point, in orange
- SA5900-903APO** Intelligent series call point, in white
- SA5900-904APO** Intelligent series call point, in yellow

SA4700-102APO

SURFACE MOUNT INPUT/OUTPUT MODULES

CE-CPR EN54-18 EN54-17



These allow checks on the status of external devices. Loop short-circuit isolator included.

- SA4700-102APO** Input/Output module
- SA4700-103APO** Input/Output module for loads of 230 V AC
- SA4700-104APO** Two inputs/two outputs module
- SA4700-100APO** Input module
- SA6700-100APO** Two inputs module
- 55000-852APO** Output module for conventional sounders
- 55000-588APO** Three inputs/outputs module
- 55000-845APO** Conventional zone interface module

SA4700-302APO

DIN RAIL MOUNT INPUT/OUTPUT MODULES

CE-CPR EN54-18 EN54-17



These allow checks on the status of external devices. Loop short-circuit isolator included.

- SA4700-302APO** Input/Output module
- SA4700-300APO** Input module
- 55000-182APO** Output module for conventional sounders
- 55000-797APO** Output module for loads of 230 V AC
- 55000-802APO** Isolator module (two channels)
- 55000-760APO** Mini Input module
- 55000-812APO** Conventional zone interface module



55000-742APO
VISUAL ALARM SIGNALLERS

CE-CPR EN54-17 EN54-23



Certified visual alarm signallers are to be considered Visual Alarm Devices (VAD).

- 55000-742APO** Ceiling mount visual signaller (C-3-8) Red plastic, white light
- 55000-745APO** Ceiling mount visual signaller (C-3-8) White plastic, white light
- 55000-741APO** Wall mount visual signaller (W-2.4-6) Red plastic, white light
- 55000-744APO** Wall mount visual signaller (W-2.4-6) White plastic, white light

55000-620APO
VID WALL MOUNT VISUAL/AUDIBLE ALARM SIGNALLERS

CE-CPR EN54-17 EN54-3



Alarm signallers with only the audible part certified, the visual part, for those models that foresee it, is not certified and thus to be considered a Visual Indication Device (VID).

- 58000-005APO** DISCOVERY Sounder with flasher
Red plastic - Red flasher
- 58000-007APO** DISCOVERY Sounder with flasher
White plastic - Red flasher
- 55000-001APO** XP95 sounder
Red plastic - With isolator
- 55000-002APO** XP95 sounder
White plastic - With isolator
- 55000-005APO** XP95 Sounder with flasher
Red plastic - Red flasher
- 55000-274APO** XP95 Open area sounder for outdoor installation
Red plastic
- 55000-291APO** XP95 Open area sounder with flasher
Red plastic - Red flasher
- 55000-293APO** XP95 Open area sounder with flasher
Red plastic - Red flasher - With isolator
- 55000-294APO** XP95 Open area sounder with flasher
White plastic - Red flasher - With isolator
- 55000-296APO** XP95 Open area sounder with flasher for outdoor installation
Red plastic - Red flasher
- 55000-298APO** XP95 Open area sounder with flasher
Red plastic - Red flasher - With isolator
- 55000-299APO** XP95 Open area sounder with flasher for outdoor installation
White plastic - Red flasher - With isolator



45681-278APO

MOUNTING BASE FOR APOLLO DETECTORS WITH ALARM SIGNALLERS



Alarm signallers integrated into the detector mounting bases. Signallers, depending on the models, are available with the visual part certified (VAD) or non-certified (VID), in the audible-only or visual-audible version, with or without short-circuit isolator.

45681-278APO	XP95 sounder base with own address
45681-276APO	XP95 sounder base activated by remote detector output
45681-277APO	XP95 sounder base with own address and short-circuit loop isolator
45681-702APO	DISCOVERY sounder base with own address and isolator
45681-300APO	DISCOVERY sounder base with own address and short-circuit isolator Loop - DIN tone
45681-290APO	DISCOVERY sounder base with own address and short-circuit isolator Loop, Slow Whoop tone
45681-331APO	XP95 sounder base with own address Red VID flasher
45681-330APO	XP95 sounder base with own address Red VID flasher, with short-circuit loop isolator
45681-332APO	XP95 sounder base with own address Red VID flasher, with short-circuit loop isolator, DIN tone
45681-393APO	DISCOVERY sounder base with own address Red VID flasher, with short-circuit loop isolator
45681-705APO	XP95 sounder base with own address Red VAD flasher (cat. O), with short-circuit loop isolator
45681-707APO	XP95 sounder base with own address Red VAD flasher (cat. O), with short-circuit loop isolator, DIN tone
45681-700APO	DISCOVERY sounder base with own address Red VAD flasher (cat. O), with short-circuit loop isolator

WD100





Wireless devices



See the online section

The revolutionary FireVibes system

The FireVibes system represents an excellent solution for those installations where the connection of detectors would result difficult or excessively expensive (museums, churches, etc.).

The protocol translator, which connects and is powered directly via the loop, allows the control panel to communicate with up to 128 wireless devices. The communication between translator and devices can be either direct or through repeater modules which allow range extension and the creation of a redundant network which offers alternative routes in the event of the loss of a node.

Wireless communication is based on two-way dual channel technology capable of guaranteeing a distance of up to 200 meters between translators and devices (Field Bus) and up to 1000 meters between translators and expansions (Network Bus). The range of wireless devices available includes optical smoke detectors, temperature detectors, multicriteria detectors, call points, input modules and sounders.

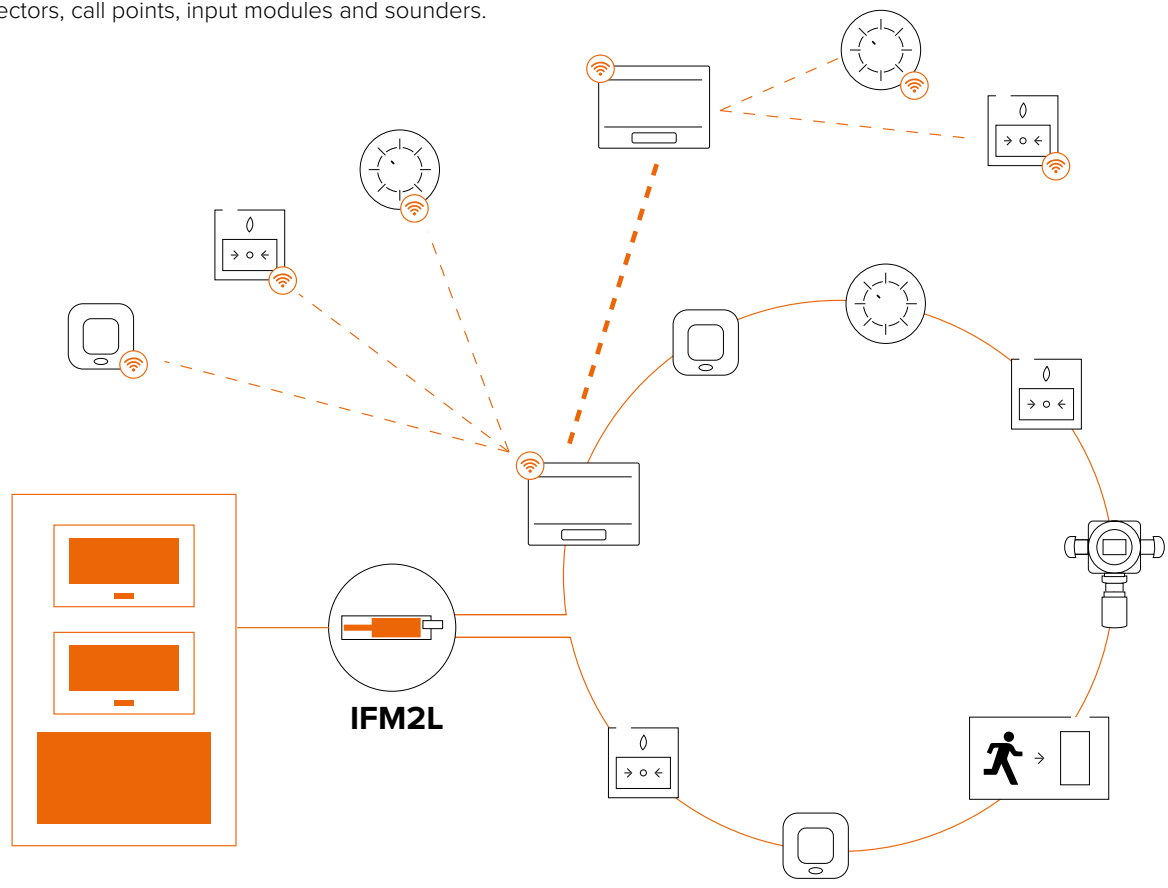



EWT100

TRANSLATOR FROM INIM LOOP TO WIRELESS DEVICES

CE-CPR EN54-17 EN54-18 EN54-25



It is recognized on the loop as an Inim addressable device and occupies, in addition to its own, an address for each wireless device associated with it. The translator can manage directly up to a maximum of 32 wireless devices or, by adding XWT100 expansion modules, up to a maximum of 128 devices. It is powered via the Loop or via a local power source by connecting a 24 V power supply.

- Built-in short-circuit isolator
- Mesh network with redundant route to expansion modules
- Two-way wireless communication
- Internal antenna
- Communication range up to 1Km towards translators and expansion modules, up to 200m between translator/expansion modules and wireless devices

EWT100/B Translator, in black

TECHNICAL SPECIFICATIONS

Power supply voltage:	18 - 33 V DC	Protection grade:	IP30
Frequency:	868 - 870 Mhz	Maximum humidity:	90% RH
Maximum radiated power:	14 dBm (25 mW)	Dimension:	235 x 160 x 70 mm
Operating temperature:	-10° ... +55° C	Weight:	700 g

XWT100

WIRELESS EXPANSION

CE-CPR EN54-18 EN54-25



Compatible with EWT100 translators, allows increase of range and extension of the Fire Vibes wireless system. Each expansion can manage a maximum of 32 devices, each FireVibes system manages up to 15 XWT100 expansions.

The expansions automatically manage redundant routes, in such a way that if one expansion in the chain fails the communication will find an alternate route. Redundant routes are identified and tested during system commissioning. All expansions are fully monitored to ensure that the highest levels of safety are maintained. The module is powered by a voltage of 24 V.

- Built-in short-circuit isolator
- Mesh network with redundant route to expansion modules
- Two-way wireless communication
- Internal antenna
- Wireless communication range up to 1Km toward translators and expansion modules, up to 200 m between translator/expansion modules and wireless devices
- Up to 32 manageable wireless devices
- Wireless links based on dual channel
- Wireless devices completely managed individually via control panel
- Configuration of wireless devices from keypad and local display screen or via FireVibes Studio software

XWT100/B Expansion, in black

TECHNICAL SPECIFICATIONS

Power supply voltage:	9 - 30 V DC	Protection grade:	IP30
Frequency:	868 - 870 Mhz	Maximum humidity:	90% RH
Maximum radiated power:	14 dBm (25 mW)	Dimension:	235 x 160 x 70 mm
Operating temperature:	-10° ... +55° C	Weight:	700 g

WD100
WIRELESS FIRE DETECTORS

CE-CPR EN54-25 EN54-5 EN54-7



WD100 SMOKE DETECTOR
WD100B SMOKE DETECTOR BLACK COLOUR

Based on a dual infrared detection optics (double reflection angle), guarantees rapid smoke detection and high rejection of false alarms. The detector is completely managed by the control panel (if combined with addressed control panels) and the individual details relating to its status are shown on the same.

WD200 HEAT DETECTOR
WD200B HEAT DETECTOR BLACK COLOUR

Capable of signalling the presence of a fire hazard based on the temperature detected in the environment. The detector is completely managed by the control panel (if combined with addressed control panels) and the individual details relating to its status are shown on the same. It can be set from the control panel as rate-of-rise (AIR) or fixed high temperature (BS).

WD300 SMOKE AND HEAT DETECTOR
WD300B SMOKE AND HEAT DETECTOR BLACK COLOUR

The WD300 detector combines the features of the WD100 wireless smoke detectors and the WD200 temperature detectors in a single detector. The detector is completely managed by the control panel (if combined with addressed control panels) and the individual details relating to its status are shown on the same.

TECHNICAL SPECIFICATIONS

Batteries:	2 x CR123 A	Protection grade:	IP40
Frequency:	868 - 870 Mhz	Maximum humidity:	95% RH
Maximum radiated power:	14 dBm (25 mW)	Dimension:	110 x 70 mm
Operating temperature:	-10° ... +55° C	Weight:	155 g

WC0010
WIRELESS CALLPOINT

CE-CPR EN54-11 EN54-25



The WC0010 call point, compatible with EWT100 addressable translators or XWT100 expansions, allows the manual signalling of a fire danger condition. Resettable after activation by means of the plastic key (supplied), replacement of parts not required.

- Wireless communication based on two redundant channels
- Communication range extendable up to 200 m
- Standard lithium battery guaranteed 10 years

TECHNICAL SPECIFICATIONS

Batteries:	2 x CR123 A	Protection grade:	IP42
Maximum humidity:	95% RH	Dimension:	88 x 87 x 61 mm
Frequency:	868 - 870 Mhz	Weight:	160 g
Maximum radiated power:	14 dBm (25 mW)		
Operating temperature:	-10° ... +55° C		



WM202SR
WIRELESS OUTPUT MODULE

CE-CPR EN54-18 EN54-25



The WM202SR output module is equipped with a relay output (Dry contact) and a supervised output capable of supplying a voltage of 12 or 24 V DC starting from the internal battery. The module is completely managed by the control panel (if combined with addressed control panels).

- Two-way wireless communication
- Wireless communication range extendable (up to 200 m)
- Standard lithium battery guaranteed 5 years

TECHNICAL SPECIFICATIONS

Relay output:	2 A @ 30 V DC	Protection grade:	IP65
Frequency:	868 - 870 Mhz	Dimension:	88 x 87 x 61 mm
Maximum radiated power:	14 dBm (25 mW)	Weight:	233 g
Operating temperature:	-10° ... +55° C	Batteries:	2 x CR123A
Maximum current on supervised outputs:	100 mA @ 12 V DC 50 mA @ 24 V DC		

WM110
WIRELESS INPUT MODULE

CE-CPR EN54-18 EN54-25



The WM110 input module is equipped with a supervised input and is compatible with EWT100 addressable translators or XWT100 expansions.

- Two-way wireless communication
- One supervised input
- Wireless communication range extendable (up to 200 m)
- Standard lithium battery guaranteed 10 years

TECHNICAL SPECIFICATIONS

Relay output:	2A @ 30 V DC	Protection grade:	IP65
Frequency:	868 - 870 Mhz	Dimension:	88 x 87 x 61 mm
Maximum radiated power:	14 dBm (25 mW)	Weight:	233 g
Operating temperature:	-10° ... +55° C	Batteries:	2 x CR123A
Maximum current on supervised outputs:	100 mA @ 12 V DC 50 mA @ 24 V DC		

WSB1010

SOUNDER BASE FOR WIRELESS DETECTORS

CE-CPR EN54-3 EN54-25



Occupies its own address in order to be managed independently by the detector it is associated with. It manages 32 different tones selectable via DIP switch and can be activated with two different tones (pre-alarm and alarm activation). The sounder base is compatible with the EWT100 addressable translators or the XWT100 expansions modules. The signaller can be used as a standalone ceiling-mount signaller (without detector) using the optional white or red cap.

- Two-way wireless communication
- Wireless communication based on two redundant channels
- Wireless communication range extendable (up to 200 m)
- Standard lithium batteries guaranteed 5 years
- Uses low cost standard lithium batteries

WSB1010	Sounder base for wireless detectors
WSB1010B	Sounder base for wireless detectors, in black
LID200-AL/W	White cap for installation without detector
LID200-AL/R	Red cap for installation without detector

TECHNICAL SPECIFICATIONS

Maximum humidity:	95% RH	Protection grade:	IP21
Frequency:	868 - 870 Mhz	Dimension:	129 x 54 mm
Maximum radiated power:	14 dBm (25 mW)	Weight:	221 g
Operating temperature:	-10° ... +55° C	Batteries:	2 x CR123A
Sound output:	from 88 to 91 dB		

WSB1020

SOUNDERBEACON BASE FOR WIRELESS DETECTORS

CE-CPR EN54-3 EN54-23 EN54-25



Occupies its own address in order to be managed independently by the detector it is associated with. It manages 32 different tones selectable via DIP switch and can be activated with two different tones (pre-alarm and alarm activation). The sounder base is compatible with the EWT100 addressable translators or the XWT100 expansions modules. The signaller can be used as a standalone ceiling-mount signaller (without detector) using the optional white or red cap.

- Two-way wireless communication
- Wireless communication based on two redundant channels
- Wireless communication range extendable (up to 200 m)
- Standard lithium batteries guaranteed 5 years
- Uses low cost standard lithium batteries

WSB1020	Sounderbeacon base for wireless detectors - White LED light
WSB1020B	Sounderbeacon base for wireless detectors - White LED light
WSB1021	Sounderbeacon base for wireless detectors - Red LED light
LID200-AL/W	White cap for installation without detector
LID200-AL/R	Red cap for installation without detector

TECHNICAL SPECIFICATIONS

Maximum humidity:	95% RH	Protection grade:	IP21
Frequency:	868 - 870 Mhz	Dimension:	129 x 54 mm
Maximum radiated power:	14 dBm (25 mW)	Weight:	221 g
Operating temperature:	-10° ... +55° C	Batteries:	2 x CR123A
Sound output:	from 88 to 91 dB		



WS2010RE

WALL-MOUNT WIRELESS AUDIBLE-VISUAL SIGNALLERS

CE-CPR EN54-23 EN54-25 EN54-3



The WS20x0 series wall-mount wireless alarm signallers are compatible with the EWT100 addressable translators or the XWT100 expansions modules. In the various versions they have an audible signaller with 32 selectable tones and a white light flasher.

- Activable with two different tones (pre-alarm and alarm)
- Level adjustable via DIP SWITCH (4 levels)
- Adjustable flash power
- Two-way wireless communication
- Wireless communication range extendable (up to 200 m)
- Uses standard lithium batteries, guaranteed 5 years

- WS2010RE** Wireless wall-mount audible signalling device, enclosure in red plastic
- WS2020RE** Wireless wall-mount visual/audible signalling device, enclosure in red plastic
- WS2010WE** Wireless wall-mount audible signalling device, enclosure in white plastic
- WS2020WE** Wireless wall-mount visual/audible signalling device, enclosure in white plastic

TECHNICAL SPECIFICATIONS

Maximum humidity:	95% RH	Protection grade:	IP33
Frequency:	868 - 870 Mhz	Dimension:	Ø 130 x 192 mm
Maximum radiated power:	14 dBm (25 mW)	Weight:	380 g
Operating temperature:	-10° ... +55° C	Batteries:	2 x CR123A
Sound output:	100 dB	Visual range:	W 2,5-7

WIL0010

WIRELESS REMOTE INDICATOR



The WIL0010 wireless remote warning light provides signalling of the activation of any of the detectors installed in non-accessible environments (false ceilings, floating floors) or signalling of the activation of an outdoor alarm.

- Two-way wireless communication
- Wireless communication range extendable (up to 200 m)
- Uses standard lithium batteries, guaranteed 5 years

TECHNICAL SPECIFICATIONS

Maximum humidity:	95% RH	Protection grade:	IP33
Frequency:	868 - 870 Mhz	Dimension:	80 x 80 x 32 mm
Maximum radiated power:	14 dBm (25 mW)	Weight:	66 g
Operating temperature:	-10° ... +55° C	Batteries:	2 x CR123A
Sound output:	100 dB	Visual range:	W 2,5-7

EWT100-TESTER

KIT FOR WIRELESS SIGNAL TEST



The case comprises: a test transmitter, a test detector, a Bluetooth adapter and a wireless transmitter for communication with Android APP. The kit allows the installer to carry out placement tests and evaluate the wireless signal before proceeding with the installation of the system. The wireless signal value transmitted by the test detector and test transmitter can be viewed on the App for android systems (smartphone-tablet) downloadable from the store.

- EWT100-TESTER** TEST KIT
- EWT100-DONGLE** Bluetooth adaptor - Transceiver (already included in the KIT)
- EWT100-WD2** Test detector (already included in the KIT)
- EWT100-XWT1** Test transceiver (already included in the KIT)



EWT100-DONGLE

BLUETOOTH ADAPTOR - TRANSCIEVER

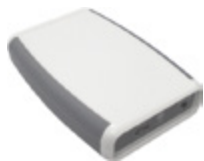

FireVibes wireless adapter, allows the connection of a PC to the translator for system management.

LID100-SG

CAPS FOR SOUNDER BASE WITHOUT DETECTOR



LID200-AL/R

Red cap

LID200-AL/W

White cap

FireVibes/STUDIO

FireVibes/STUDIO configuration software provides a complete set of advanced and easy-to-use functions for configuration, data acquisition, monitoring and reporting. The software is based on a practical and intuitive graphical interface, it allows the positioning of the devices directly on the topological map of the site for a clear representation that allows quick and safe commissioning.

- Device QR code scan with the PC camera for easy importing into the system
- Drag and drop of the devices on the site plans
- “ConfigWizard” button for automatic learning of all the devices introduced in the system
- “LiveDisplay” function provides a real-time view of the status of all system elements

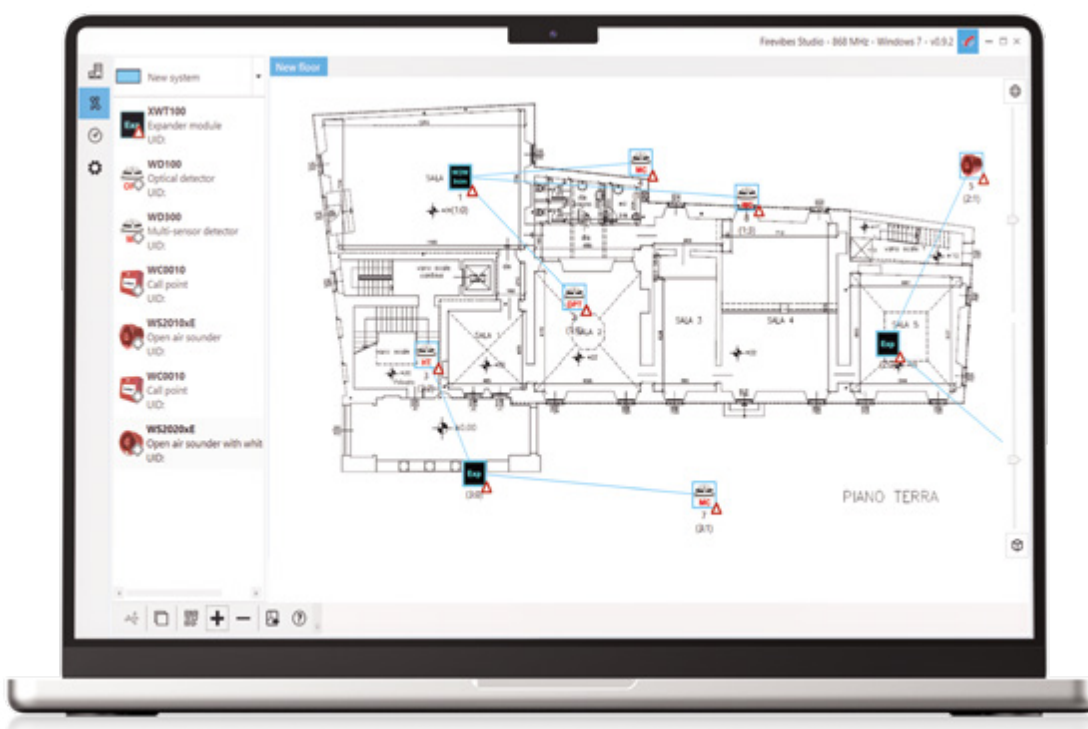



DEL F 165/6 PP



Speakers



See the
online
section

Certified diffusers for EVAC applications

The products listed in this section are characterized by high quality and fidelity in audio response. These features make them unique and capable of guaranteeing both excellent intelligibility in emergency evacuation conditions as well as quality audio for sound diffusion and public addressing.

The different models adapt to various environments by offering different solutions of assembly.

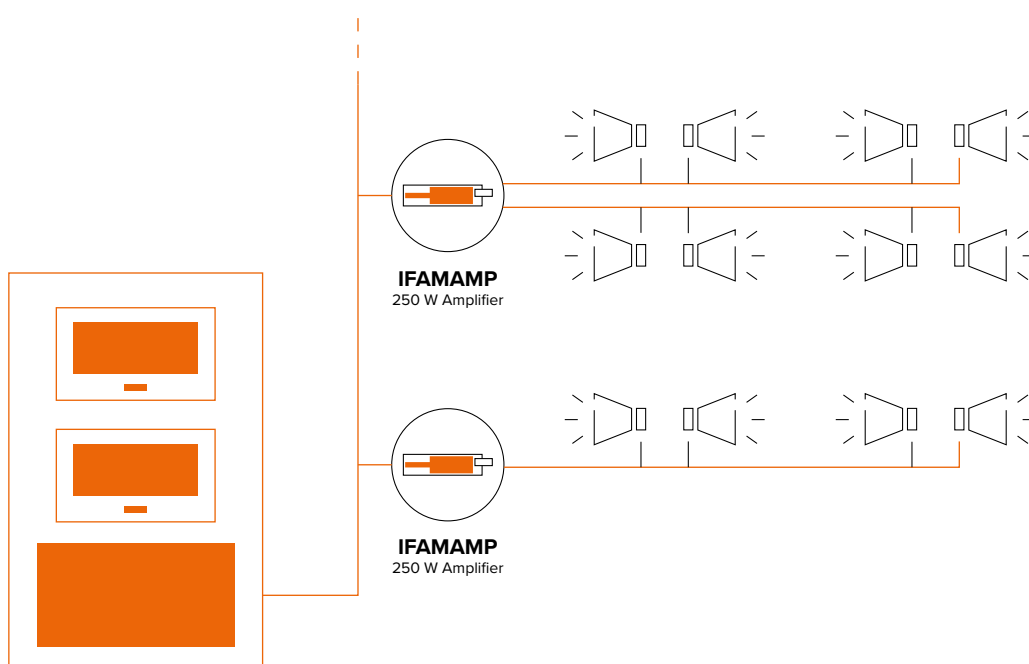



False ceiling speakers

DELFL 165/6 PP

FALSE CEILING SPEAKER FOR VOICE EVACUATION SYSTEMS



For indoor use (Type A) IP32 Adjustable power (6 / 3 / 1.5 / 0.75 W). Complete with ceramic terminals and thermal fuse

TECHNICAL SPECIFICATIONS

Max. power:	6 W @ 100 V	Material:	Metal
Min. power:	0.75 W	Dimension:	Ø 220 x 102 mm
Diameter of internal speaker:	6.5"	Colour:	RAL9016 White
SPL:	93 dB (1 W @ 1 m)		

DL-E 06-130/T-EN54 SAFE

FALSE CEILING SPEAKER FOR VOICE EVACUATION SYSTEMS



For indoor use (Type A) IP21C. Adjustable power (6 / 3 / 1.5 W).

TECHNICAL SPECIFICATIONS

Max. power:	6 W @ 100 V	Material:	Metal
Min. power:	1.5 W	Dimension:	Ø 181.5 x 66 mm
Diameter of internal speaker:	5"	Colour:	RAL9016 White
SPL:	98.3 dB (1 W @ 1 m)		

DL-E 06-165/T-EN54 SAFE

FALSE CEILING SPEAKER FOR VOICE EVACUATION SYSTEMS



For indoor use (Type A) IP21C. Adjustable power (6 / 3 / 1.5 W).

TECHNICAL SPECIFICATIONS

Max. power:	6 W @ 100 V	Material:	Metal
Min. power:	1.5 W	Dimension:	Ø 199 x 76 mm
Diameter of internal speaker:	6.5"	Colour:	RAL9016 White
SPL:	100.2 dB (1 W @ 1 m)		

DL-E 10-165/T-EN54 SAFE

FALSE CEILING SPEAKER FOR VOICE EVACUATION SYSTEMS



For indoor use (Type A) IP21C. Adjustable power (10 / 5 / 2.5 W).

TECHNICAL SPECIFICATIONS

Max. power:	10 W @ 100 V	Material:	Metal
Min. power:	1.5 W	Dimension:	Ø 199 x 73 mm
Diameter of internal speaker:	6.5"	Colour:	RAL9016 White
SPL:	95.1 dB (1 W @ 1 m)		



DL06-77/T-EN54

FALSE CEILING SPEAKER FOR VOICE EVACUATION SYSTEMS



For indoor use (Type A) IP21C. Adjustable power (10 / 5 / 2.5 W). Suitable for vandal-proof installations

TECHNICAL SPECIFICATIONS

Max. power:	6 W @ 100 V	Material:	Metal
Min. power:	1.5 W	Dimension:	Ø 104 x 100.5 mm
Diameter of internal speaker:	3"	Colour:	RAL9010 White
SPL:	84.6 dB (1 W @ 1 m)		

DAL 165/6 PP

WALL/CEILING SOUND DIFFUSER FOR SURFACE MOUNTING



For indoor use (Type A) IP21. Adjustable power (6 / 3 / 1.5 / 0.75 W). Complete with ceramic terminals and thermal fuse.

TECHNICAL SPECIFICATIONS

Max. power:	6 W @ 100 V	Material:	Metal
Min. power:	0.75 W	Dimension:	Ø 170 x 75 mm
Diameter of internal speaker:	6.5"	Colour:	RAL9010 White
SPL:	91 dB (1 W @ 1 m)		

DAL 165/10 PP

WALL/CEILING SOUND DIFFUSER FOR SURFACE MOUNTING



For indoor use (Type A) IP21. Adjustable power (10 / 6 / 3 / 1.5 W). Complete with ceramic terminals and thermal fuse.

TECHNICAL SPECIFICATIONS

Max. power:	10 W @ 100 V	Material:	Metal
Min. power:	1.5 W	Dimension:	Ø 170 x 75 mm
Diameter of internal speaker:	6.5"	Colour:	RAL9010 White
SPL:	91 dB (1 W @ 1 m)		

Wall mount speakers

WAL 165/6 PP

WALL MOUNT SOUND DIFFUSER FOR VOICE EVACUATION SYSTEMS



For indoor use (Type A) IP21. Adjustable power (6 / 3 / 1.5 / 0.75 W). Complete with ceramic terminals and thermal fuse.

TECHNICAL SPECIFICATIONS

Max. power:	6 W @ 100 V	Material:	MDF
Min. power:	0.75 W	Dimension:	253 x 193 x 83 mm
Diameter of internal speaker:	6.5"	Colour:	RAL9010 White
SPL:	98.2 dB (1 W @ 1 m)		



WAL 165/10 PP

WALL MOUNT SOUND DIFFUSER FOR VOICE EVACUATION SYSTEMS



For indoor use (Type A) IP21. Adjustable power (10 / 6 / 3 / 1.5 W). Complete with ceramic terminals and thermal fuse.

TECHNICAL SPECIFICATIONS

Max. power:	10 W @ 100 V	Material:	MDF
Min. power:	1.5 W	Dimension:	253 x 193 x 83 mm
Diameter of internal speaker:	6.5"	Colour:	RAL9010 White
SPL:	99.2 dB (1 W @ 1 m)		

WAQ 130/6 PP

WALL MOUNT SOUND DIFFUSER



For indoor use (Type A) IP21. Adjustable power (6 / 3 / 1.5 / 0.75 W). Complete with ceramic terminals and thermal fuse.

TECHNICAL SPECIFICATIONS

Max. power:	6 W @ 100 V	Material:	Metal
Min. power:	0.75 W	Dimension:	164 x 164 x 66 mm
Diameter of internal speaker:	5"	Colour:	RAL9010 White
SPL:	84 dB (1 W @ 1 m)		

WAC 165/6 PP1

WALL MOUNT BROADBAND SOUND DIFFUSER



For indoor use (Type A) IP21C. Adjustable power (6 / 3 / 1.5 / 0.75 W). Complete with ceramic terminals and thermal fuse.

TECHNICAL SPECIFICATIONS

Max. power:	6 W @ 100 V	Material:	ABS
Min. power:	0.75 W	Dimension:	330 x 209 x 84 mm
Diameter of internal speaker:	6.5"	Colour:	RAL9010 White
SPL:	96 dB (1 W @ 1 m)		

WA 06-165/T METAL-EN54

WALL MOUNT BROADBAND SOUND DIFFUSER



For indoor use (Type A) IP54. Adjustable power (6 / 3 / 1.5 W). Complete with ceramic terminals and thermal fuse. Anti-vandal enclosure.

TECHNICAL SPECIFICATIONS

Max. power:	6 W @ 100 V	Material:	Metal
Min. power:	1.5 W	Dimension:	252 x 192 x 81 mm
Diameter of internal speaker:	6.5"	Colour:	RAL9010 White
SPL:	98.3 dB (1 W @ 1 m)		

Sound projectors

DAW 130/10 PP

WALL OR CEILING MOUNT SOUND PROJECTOR



CE-CPR



EN54-24



For indoor/outdoor use (Type A/B) IP33C. Adjustable power (10 / 6 / 3 / 1.5 W). Complete with ceramic terminals and thermal fuse.

TECHNICAL SPECIFICATIONS

Max. power:	10 W @ 100 V	Material:	Aluminium
Min. power:	1.5 W	Dimension:	Ø 140 x 65 mm
Diameter of internal speaker:	5"	Colour:	RAL9010 White
SPL:	85 dB (1 W @ 1 m)		

DAW 130/20 PP

WALL OR CEILING MOUNT SOUND PROJECTOR



CE-CPR



EN54-24



For indoor/outdoor use (Type A/B) IP33C. Adjustable power (20 / 15 / 10 / 5 W). Complete with ceramic terminals and thermal fuse.

TECHNICAL SPECIFICATIONS

Max. power:	20 W @ 100 V	Material:	Aluminium
Min. power:	5 W	Dimension:	Ø 140 x 65 mm
Diameter of internal speaker:	5"	Colour:	RAL9010 White
SPL:	86 dB (1 W @ 1 m)		

DAW-K 130/10 PP

WALL OR CEILING MOUNT SOUND PROJECTOR



CE-CPR



EN54-24



For indoor/outdoor use (Type A/B) IP33C. Adjustable power (10 / 6 / 3 / 1.5 W). Complete with ceramic terminals and thermal fuse.

TECHNICAL SPECIFICATIONS

Max. power:	10 W @ 100 V	Material:	ABS
Min. power:	1.5 W	Dimension:	Ø 140 x 200 mm
Diameter of internal speaker:	5"	Colour:	RAL9010 White
SPL:	100.2 dB (1 W @ 1 m)		

DAW-K 130/20 PP

WALL OR CEILING MOUNT SOUND PROJECTOR



CE-CPR



EN54-24



For indoor/outdoor use (Type A/B) IP33C. Adjustable power (20 / 15 / 10 / 5 W). Complete with ceramic terminals and thermal fuse.

TECHNICAL SPECIFICATIONS

Max. power:	20 W @ 100 V	Material:	ABS
Min. power:	5 W	Dimension:	Ø 140 x 200 mm
Diameter of internal speaker:	5"	Colour:	RAL9010 White
SPL:	93 dB (1 W @ 1 m)		



DAD 260/10 PP

TWO-WAY WALL OR CEILING MOUNT SOUND PROJECTOR



For indoor use (Type A) IP21. Adjustable power (10 / 6 / 3 / 1.5 W). Enclosure in aluminium. Complete with ceramic terminals and thermal fuse.

TECHNICAL SPECIFICATIONS

Max. power:	10 W @ 100 V	Material:	Aluminium
Min. power:	1.5 W	Dimension:	Ø 140 x 165 mm
Diameter of internal speaker:	2 x 5"	Colour:	RAL9010 White
SPL:	85 dB (1 W @ 1 m)		

DA-P 10-260/T-EN54

TWO-WAY WALL OR CEILING MOUNT SOUND PROJECTOR



For outdoor use (Type B) IP56. Adjustable power (10 / 5 / 2.5 W). Complete with ceramic terminals.

TECHNICAL SPECIFICATIONS

Max. power:	10 W @ 100 V	Material:	Aluminium
Min. power:	2.5 W	Dimension:	202 x 173 mm Ø 146
Diameter of internal speaker:	2 x 5"	Colour:	RAL9016 White
SPL:	90.7 dB (1 W @ 1 m)		

DA-S 20-130/T-EN54

TWO-WAY WALL OR CEILING MOUNT SOUND PROJECTOR



For outdoor use (Type B) IP56. Adjustable power (10 / 5 / 2.5 W). Complete with ceramic terminals.

TECHNICAL SPECIFICATIONS

Max. power:	20 W @ 100 V	Material:	Aluminium
Min. power:	5 W	Dimension:	202 x 173 mm Ø 146
Diameter of internal speaker:	2 x 5"	Colour:	RAL9016 White
SPL:	92.3 dB (1 W @ 1 m)		

SPI-P620100

WALL OR CEILING MOUNT SOUND PROJECTOR IN ABS



Projection-type sound diffuser Assembly by means of the included metal coupling bracket, adjustable, flame-resistant ABS thermoplastic casing, metal grille for the protection of the visible section. Supports 70 V or 100 V lines, by means of a selector it can be set to provide a 5/10/20 W power supply.

TECHNICAL SPECIFICATIONS

Power:	5 / 10 / 20 W (internal selector)	Material:	ABS
SPL:	92 dB (1 W @ 1 m)	Dimension:	Ø 170 x 245 mm
Diameter of internal speaker:	6.5"	Colour:	RAL9016 White

SPI-P620110

WALL OR CEILING MOUNT SOUND PROJECTOR IN ALUMINIUM



CE-CPR



EN54-24



Projection-type sound diffuser Assembly by means of the included metal coupling bracket, adjustable, aluminium casing, metal grille for the protection of the visible section. Supports 70 V or 100 V lines, by means of a selector it can be set to provide a 5/10/20 W power supply.

TECHNICAL SPECIFICATIONS

Power:	5 / 10 / 20 W (internal selector)	Material:	Aluminium
Diameter of internal speaker:	6.5"	Dimension:	Ø 170 x 252 mm
SPL:	98 dB (1 W @ 1 m)	Colour:	Grey RAL7035

Horn sound diffuser

DK 10/T-EN54-PG

WALL OR CEILING MOUNT HORN SOUND DIFFUSER



CE-CPR



EN54-24



For outdoor use (Type B) IP66. Adjustable power (10 / 5 / 2.5 / 1.25 W). Complete with ceramic terminals.

TECHNICAL SPECIFICATIONS

Max. power:	10 W @ 100 V	Material:	ABS
Min. power:	1.25 W	Dimension:	142 x 256 mm
Diameter of internal speaker:	5"	Colour:	Grey RAL7035
SPL:	106.7 dB (1 W @ 1 m)		

DK 15/T-EN54-PG

WALL OR CEILING MOUNT HORN SOUND DIFFUSER



CE-CPR



EN54-24



For outdoor use (Type B) IP66. Adjustable power (15 / 7.5 / 3.75 / 1.9 W). Complete with ceramic terminals.

TECHNICAL SPECIFICATIONS

Max. power:	15 W @ 100 V	Material:	ABS
Min. power:	2 W	Dimension:	209 x 321 mm
Diameter of internal speaker:	5"	Colour:	Grey RAL7035
SPL:	86 dB (1 W @ 1 m)		

DK 30/T-EN54-PG

WALL OR CEILING MOUNT HORN SOUND DIFFUSER



CE-CPR



EN54-24



For outdoor use (Type B) IP66. Adjustable power (30 / 20 / 10 / 5 W). Complete with ceramic terminals.

TECHNICAL SPECIFICATIONS

Max. power:	30 W @ 100 V	Material:	ABS
Min. power:	5 W	Dimension:	235 x 351 mm
Diameter of internal speaker:	5"	Colour:	Grey RAL7035
SPL:	110.1 dB (1 W @ 1 m)		



Column sound diffuser

TSU 300/10 PP

WALL MOUNT COLUMN SOUND DIFFUSER



For outdoor use (Type B) IP66. Adjustable power (10 / 6 / 3 / 1.5 W). Complete with ceramic terminals and thermal fuse.

TECHNICAL SPECIFICATIONS

Max. power:	10 W @ 100 V	Material:	Aluminium
Min. power:	1.5 W	Dimension:	285 x 100 x 92 mm
Diameter of internal speaker:	2 x 3"	Colour:	Grey RAL9006
SPL:	97.6 dB (1 W @ 1 m)		

TSU 500/20 PP

WALL MOUNT COLUMN SOUND DIFFUSER

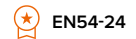

For outdoor use (Type B) IP66. Adjustable power (20 / 15 / 10 / 5 W). Complete with ceramic terminals and thermal fuse.

TECHNICAL SPECIFICATIONS

Max. power:	20 W @ 100 V	Material:	Aluminium
Min. power:	5 W	Dimension:	510 x 100 x 92 mm
Diameter of internal speaker:	4 x 3"	Colour:	Grey RAL9006
SPL:	100.3 dB (1 W @ 1 m)		

TSU 700/30 PP

WALL MOUNT COLUMN SOUND DIFFUSER



For outdoor use (Type B) IP66. Adjustable power (30 / 15 / 7.5 W). Complete with ceramic terminals and thermal fuse.

TECHNICAL SPECIFICATIONS

Max. power:	30 W @ 100 V	Material:	Aluminium
Min. power:	7.5 W	Dimension:	700 x 100 x 92 mm
Diameter of internal speaker:	6 x 3"	Colour:	Grey RAL9006
SPL:	101.3 dB (1 W @ 1 m)		

TSU 1000/50 PP

WALL MOUNT COLUMN SOUND DIFFUSER



For outdoor use (Type B) IP66. Adjustable power (50 / 30 / 15 / 7.5 W). Complete with ceramic terminals and thermal fuse.

TECHNICAL SPECIFICATIONS

Max. power:	50 W @ 100 V	Material:	Aluminium
Min. power:	7.5 W	Dimension:	971 x 100 x 92 mm
Diameter of internal speaker:	8 x 3"	Colour:	Grey RAL9006
SPL:	102.8 dB (1 W @ 1 m)		

Wall mount two-way sound diffuser

SPI-W420200

WALL MOUNT TWO-WAY SPEAKER WITH BASS REFLEX



Wall mount two-way sound diffuser (4" speaker, 1" tweeter) Surface mount by means of the included metal coupling bracket, adjustable, flame-resistant ABS thermoplastic casing, metal grille for the protection of the visible section. Supports lines at 70 V or 100 V, by means of a selector it can be set to provide a 2.5/5/10 or 20W power supply.

TECHNICAL SPECIFICATIONS

Power:	2.5 / 5 / 10 / 20 W (internal selector)	Material:	ABS
SPL:	88 dB (1 W @ 1 m) 99 dB (6 W @ 1 m)	Dimension:	270 x 170 x 170 mm
Speaker / Tweeter:	4" - 1"	Colour:	Black

SPI-W520200

WALL MOUNT TWO-WAY SPEAKER WITH BASS REFLEX

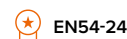

Wall mount two-way sound diffuser (5" speaker, 1.5" tweeter). Surface mount by means of the included metal coupling bracket, adjustable, flame-resistant ABS thermoplastic casing, metal grille for the protection of the visible section. Supports 70 V or 100 V lines, by means of a selector it can be set to provide a 7.5/15/30W power supply.

TECHNICAL SPECIFICATIONS

Power:	7.5 / 15 / 30 W (internal selector)	Material:	ABS
SPL:	92 dB (1 W @ 1 m)	Dimension:	295 x 185 x 185 mm
Speaker / Tweeter:	5" - 1.5"	Colour:	Black

SPI-W640200

WALL MOUNT TWO-WAY SPEAKER WITH BASS REFLEX



Wall mount two-way sound diffuser (6.5" speaker 1.5" tweeter) Surface mount by means of the included metal coupling bracket, adjustable, flame-resistant ABS thermoplastic casing, metal grille for the protection of the visible section. Supports 70 V or 100 V lines, by means of a selector it can be set to provide a 5/10/20/40W power supply.

TECHNICAL SPECIFICATIONS

Power:	5 / 10 / 20 / 40 W (internal selector)	Material:	ABS
SPL:	92 dB (1 W @ 1 m)	Dimension:	330 x 200 x 220 mm
Speaker / Tweeter:	6.5"+ 1.5"	Colour:	Black

MS 15-100/T-EN54

WALL-MOUNT TWO WAY SOUND DIFFUSER WITH HIGH SOUND QUALITY



For outdoor use (Type B) IP66. Adjustable power (15 / 7.5 / 3.75 / 1.8 W).

TECHNICAL SPECIFICATIONS

Max. power:	15 W @ 100 V	Material:	ABS
Min. power:	3.7 W	Dimension:	210 x 130 x 120 mm
Diameter of internal speaker:	2 x 3"	Colour:	Grey RAL9006
SPL:	85.5 dB (1 W @ 1 m)		



MS 30-130/T-EN54

WALL-MOUNT TWO WAY SOUND DIFFUSER WITH HIGH SOUND QUALITY



For outdoor use (Type B) IP66. Adjustable power (30 / 15 / 7.5 / 2.5 W).

TECHNICAL SPECIFICATIONS

Max. power:	30 W @ 100 V	Material:	ABS
Min. power:	7.5 W	Dimension:	260 x 160 x 152mm
Diameter of internal speaker:	4 x 3"	Colour:	Grey RAL9006
SPL:	87.4 dB (1 W @ 1 m)		

MS 50-165/T-EN54

WALL-MOUNT TWO WAY SOUND DIFFUSER WITH HIGH SOUND QUALITY



For outdoor use (Type B) IP66. Adjustable power (50 / 25 / 12.5 / 6.25 W).

TECHNICAL SPECIFICATIONS

Max. power:	50 W @ 100 V	Material:	ABS
Min. power:	6.25 W	Dimension:	326 x 202 x 192
Diameter of internal speaker:	6 x 3"	Colour:	Grey RAL9006
SPL:	88.8 dB (1 W @ 1 m)		

Pendant mount sound diffusers

SPI-CP620100

PENDANT MOUNT SOUND PROJECTOR IN ABS THERMOPLASTIC



Projection-type sound diffuser with 6.5" speaker. Pendant mount, flame resistant ABS casing, metal grille for the protection of the visible section. Supports 70V or 100V lines, by means of a selector it can be set to provide a 5/10/20 W power supply.

TECHNICAL SPECIFICATIONS

Power:	5 / 10 / 20 W (internal selector)	Material:	ABS
Diameter of internal speaker:	6.5"	Dimension:	Ø 170 x 245 mm
SPL:	92 dB (1 W @ 1 m)	Colour:	RAL9016 White

DELK 130/10 PP1

CEILING MOUNT SPHERE-SHAPED SOUND DIFFUSER



For indoor use (Type A) IP32. Adjustable power (10 / 6 / 3 / 1.5 W). Complete with 5m cable with mounting box, ceramic terminals and thermal fuse.

TECHNICAL SPECIFICATIONS

Max. power:	10 W @ 100 V	Material:	Powder-paint coated steel enclosure
Min. power:	1.5 W	Dimension:	Ø 180
Diameter of internal speaker:	5"	Colour:	RAL9010 White
SPL:	88 dB (1 W @ 1 m)		



DELK 130/20 PP1

CEILING MOUNT SPHERE-SHAPED SOUND DIFFUSER



CE-CPR



EN54-24

For indoor use (Type A) IP32. Adjustable power (20 / 15 / 105 W). Complete with 5m cable with mounting box, ceramic terminals and thermal fuse.



TECHNICAL SPECIFICATIONS

Max. power:	20 W @ 100 V	Material:	Powder-paint coated steel enclosure
Min. power:	5 W	Dimension:	Ø 180
Diameter of internal speaker:	5"	Colour:	RAL9016 White
SPL:	85 dB (1 W @ 1 m)		

DEL-W 165/6 PP

CEILING MOUNT SPHERE-SHAPED SOUND DIFFUSER



CE-CPR



EN54-24

For indoor use (Type A) IP32C. Adjustable power (6 / 3 / 1.5 / 0.75 W). Complete with 5m cable with mounting box, ceramic terminals and thermal fuse.



TECHNICAL SPECIFICATIONS

Max. power:	6 W @ 100 V	Material:	Powder-paint coated steel enclosure
Min. power:	0.75 W	Dimension:	Ø 210 x 75 mm
Diameter of internal speaker:	6.5"	Colour:	RAL9016 White
SPL:	93 dB (1 W @ 1 m)		

DEL-W 165/10 PP

CEILING MOUNT SPHERE-SHAPED SOUND DIFFUSER



CE-CPR



EN54-24

For indoor use (Type A) IP32C. Adjustable power (10 / 6 / 3 / 1.5 W). Complete with 5m cable with mounting box, ceramic terminals and thermal fuse.



TECHNICAL SPECIFICATIONS

Max. power:	10 W @ 100 V	Material:	Powder-paint coated steel enclosure
Min. power:	1.5 W	Dimension:	Ø 210 x 75 mm
Diameter of internal speaker:	6.5"	Colour:	RAL9016 White
SPL:	93 dB (1 W @ 1 m)		

Multiple terminal blocks in steatite

BM 9516

FIREPROOF TERMINAL BLOCKS



BM 9516

BM 9517

BM 9518

BM 9519

BM 9520

BM 9521

BM 9522

BM 9523

BM 9524

4 mm² 1 POLE TERMINAL BLOCK IN STEATITE

4 mm² 2 POLE TERMINAL BLOCK IN STEATITE

4 mm² 3 POLE TERMINAL BLOCK IN STEATITE

6 mm² 1 POLE TERMINAL BLOCK IN STEATITE

6 mm² 2 POLE TERMINAL BLOCK IN STEATITE

6 mm² 3 POLE TERMINAL BLOCK IN STEATITE

16 mm² 1 POLE TERMINAL BLOCK IN STEATITE

16 mm² 2 POLE TERMINAL BLOCK IN STEATITE

16 mm² 3 POLE TERMINAL BLOCK IN STEATITE

Aperol Spritz 7,5
Estandon
Heritage
Rosé
glas 6,5
Plus 30,-



Conventional fire control panels

Immediate installation and simplified management

Conventional fire-fighting systems are ideal for small and medium-sized installations such as commercial premises, offices, homes, where the need for practicality and programming speed prevails. The connection between the control panel and the detection devices is achieved via connection lines with two-pole cables, so that the control and recognition of the area involved in the risk of fire is dealt with by zone.

Each cable can manage up to 32 conventional devices, the Internet connection allows adjustment to the configuration parameters remotely and management of the fire-fighting system via the SmartLook and Hevoluto monitoring software, based on graphic maps.

The immediacy of installation and management of these systems combines with wide flexibility, given by the innumerable advanced functions provided: timers, multifunction inputs, customizable outputs, BUS connection, programming of the control panel via the frontal display panel.



Quick installation and programming



Easy and effective control of small and medium-sized ambients



Internet network board for remote management



Simplified maintenance and diagnostic functions thanks to the EITK2000 Tool





SmartLine

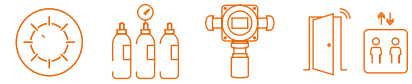

Conventional control panel for fire detection and alarm systems

The SmartLine conventional fire-detection control panel series offers a 2 zone non-expandable model, a 4 zone model expandable to 20 zones and a 4 zone model expandable to 36 zones. The extreme compactness, the simplicity of use and programming make it the ideal choice for all small and medium-sized installations, however the countless functions (timers, logic equations, etc.), enormous flexibility (self-adapting output balancing, multifunction inputs, customizable outputs, integration of gas functions, etc.) and innovative connectivity (RS485 bus for power stations, internet connection, etc.) make it an instrument suitable for satisfying any requirement in any installation.

SmartLine control panels have supervised outputs (one on the motherboard and one on each added expansion) for the activation of audio-visual signalling devices, a customizable relay output, fault signaling outputs and two 24 V outputs (one constant and one interruptible by installer-defined conditions). Additionally, each detection zone provides a terminal which can be configured as: open-collector output (activated by programmable conditions), supervised input, or Gas 4-20mA detector interface. The user interface provides an intuitive graphic display and a series of signalling LEDs located on the front of the control panel, moreover it is possible to connect up to 4 remote control panels (SmartLetUSee/LCD-Lite) to the 485 BUS (supplied) which replicate the information and functions available on the front panel, the BUS also supports two power-supply stations.

Programming via the front panel is surprisingly simple and intuitive thanks to the graphic display, to operate more easily it is possible to configure the control panel using the SmartLeague configuration software. The SmartLAN/485 board allows the control panel to connect to an Ethernet network for remote access via the Internet.



TECHNICAL SPECIFICATIONS

Power supply voltage:	230 V~ (-15% / +10%) 50/60 Hz	020 dimensions:	322 x 324 x 86 mm
Maximum internal power current:	4 A (036); 1.5 A (020)	020 weight without battery:	3.3 Kg
Maximum external load current:	4 A (036); 1.5 A (020)	036 dimensions:	497 x 380 x 97 mm
Battery specifications:	2 x 12 V @ 17 Ah (036) 2 x 12 V @ 7 Ah (020)	036 weight without battery:	6.1 Kg
Operating temperature:	-5° ... +40° C		



See the
online
section



EN54 certified

SmartLine has obtained all applicable EN54 certifications:

- EN54-2: Control panel and signalling devices;
- EN54-4: Power supply units
- EN54-21: Remote signalling and transmission equipment for events of Alarm and fault
- EN12094-1: Automatic electrical command and shutdown and delay management devices
- EN54-13: Compatibility of system components.

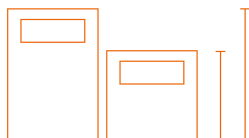

Flexible

Conventional fire-detection control panel, available in a 2 zone model, 4 zone model expandable to 20 zones, 4 zone model expandable to 36 zones. Backlit graphic display for intuitive management of the installer and user interface, navigation keys and keys for quick access to the main functions (mute, reset, evacuate, investigate)



Internal power supply

Switching power supply/battery charger 1.4 A @ 27.6 V DC (for SmartLine020) or 4A @ 27.6 V DC (for SmartLine036-4); Battery housing for two 7 Ah – 12 V batteries (for SmartLine020) or two 17 Ah – 12 V batteries (for SmartLine036-4). Battery efficiency test and battery charge voltage in accordance with temperature, battery shutdown in the event of deep discharge conditions Metal enclosure

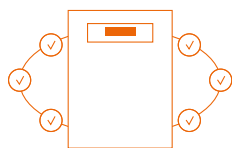

Complete

- 1 supervised alarm output (NAC)
- 1 output for communicator/dialler activation
- 1 dry-contact alarm output
- 1 dry-contact fault signalling output
- 1 power supply output for ancillary devices
- 1 interruptible power supply output for ancillary devices
- 1 additional terminal per zone configurable as: open-collector output, supervised input, Gas detector input with 4-20 mA interface
- 8 timers, 8 logical equations, automatic balancing of individual detector lines



Certified for fire extinguishing systems

Management of an extinguishing channel by adding the optional SmartLetLoose/One (EN12094-1 approved) fire extinction module

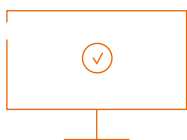

Easy to configure

Intuitive programming from the front panel; RS232 connector for programming via PC, SmartLeague programming software available free of charge

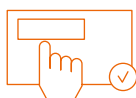

Remote keypads

RS485 BUS for repeater panel and power-supply station (SmartLevel) connections



TCP-IP connection

Optional board for connections to Ethernet networks, remote programming and supervision via BMS software Remote communicator via SIA-IP protocol





SmartLine control panel diagram

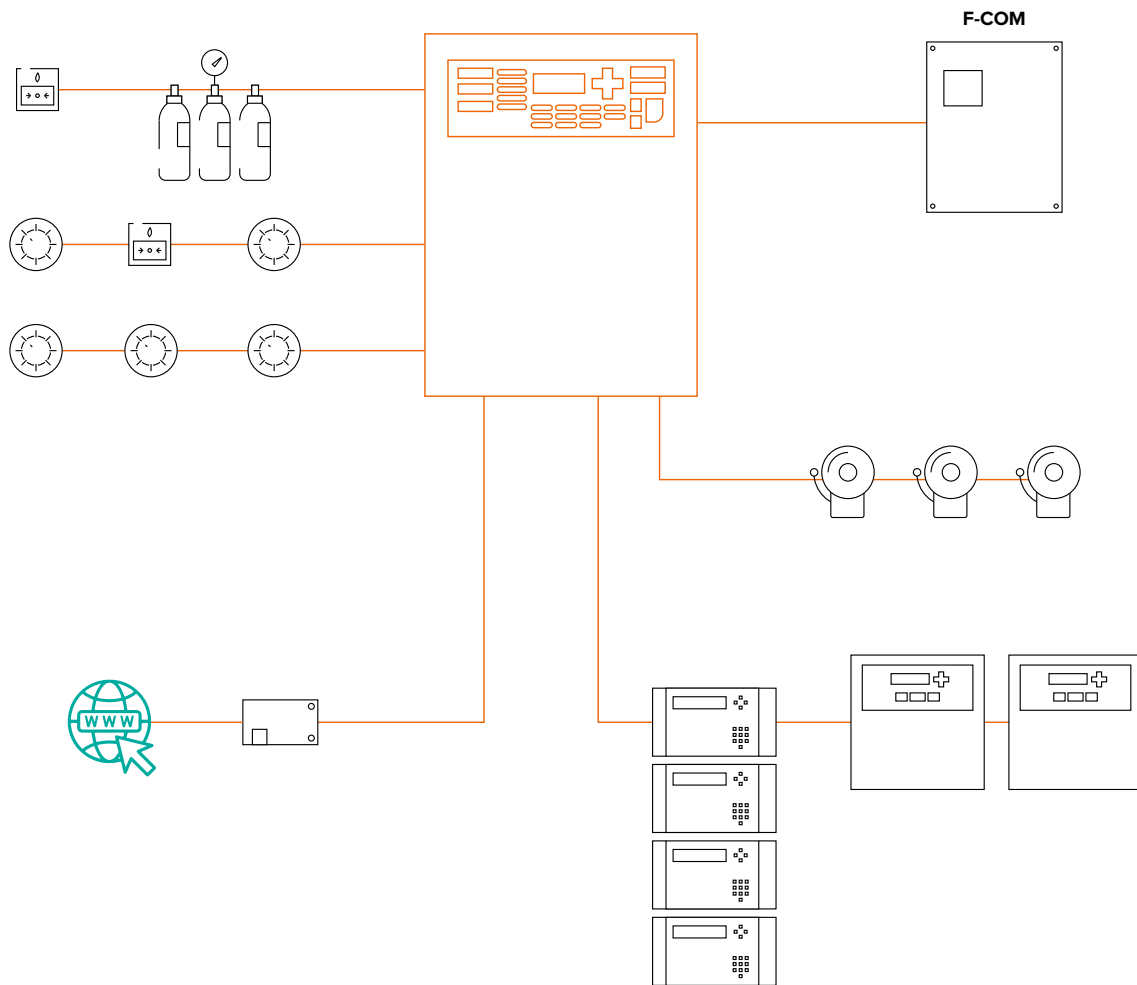

ORDER CODES	ON-BOARD ZONES		EXPANDABLE		POWER-SUPPLY
	2	4	20	36	
SmartLine020-2	✓				1.5 A
SmartLine020-4		✓	✓		1.5 A
SmartLine036-4		✓		✓	4 A

SmartLeague software

SOFTWARE FOR THE CONFIGURATION OF SMARTLINE CONTROL PANELS

The SmartLeague programming and management software is intuitive and simple to use. This indispensable tool allows security professionals to control INIM fire detection systems with ease.

In addition to allowing fast configuration of the control panel parameters, it offers an overview of the system and provides wiring diagrams of the various terminals in function of the set options.



Accessory devices for SmartLine

SMARTLETUSEE/LCD-LITE

REMOTE CONTROL AND VISUALIZATION PANEL WITH LCD SCREEN.



Remote repeater panel equipped with LCD display and user-interface keypad (up to 4 for each control panel).

SMARTLINE/8Z

8 ZONE EXPANSION BOARD



8 zone expansion board equipped with an additional supervised output.

SMARTLAN/485

BOARD FOR ETHERNET NETWORK CONNECTION



Board for connection to Ethernet networks, allows remote programming and monitoring via software based on SmartLook and Hevoluto graphic maps. The board implements the SIA-IP communication protocol.

SMARTLINE/LOGEXP

EVENT MEMORY BOARD

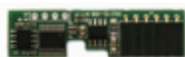

Log event capacity expansion board for the storage of the last 2,000 events that occurred in the system. SmartLine/LOGEXP provides a non-volatile memory of the events log that retains stored data even when the control panel is turned off.

SMARTLETLOOSE/ONE

FIRE EXTINGUISHMENT BOARD



Equipping the control panel with this board provides a GAS extinguishing channel certified according to the EN12094-1 standard.

SmartLetLoose/ONE enhanced control panels provide all the functions required by the applicable normative and are capable of managing all devices required for fire extinction system management. (refer to "Accessory items for fire extinction systems").

DIAGRAM KEY

- A Loop (zone A)
- B Loop (zone B)
- C SmartLight fire extinction control panel.
- D Extinguishing gas cylinders.
- E Gas release nozzles
- F Gas collectors
- G Pneumatic release valve
- H Pilot cylinder for gas release
- I Pilot cylinder electrovalve.
- L Pressure switch
- M Manual activation button
- N Stop extinction button
- O Audio/Visual signaller of imminent gas release
- P Audio/Visual signaller of gas present

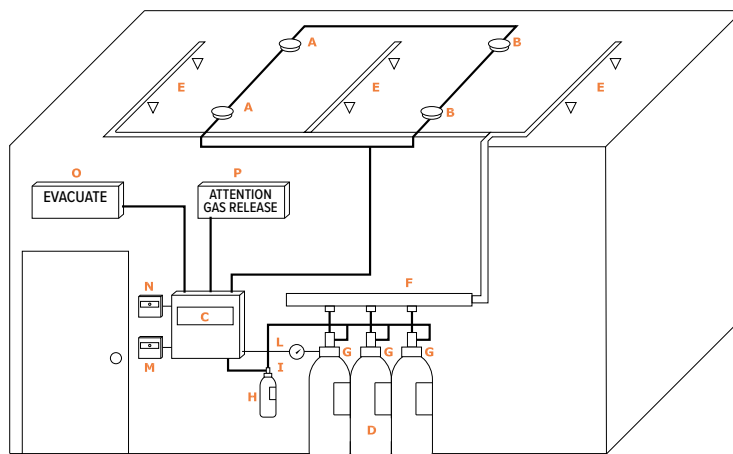



ID100

ID100

Iris series conventional devices



See the
online
section

Easy installation and advanced technology

The IRIS series conventional point detectors and manual call points are designed for connection to conventional control panels or Loop modules for managing conventional lines.

Characterized by their low cost and ease of installation, they provide sophisticated technology that makes them unique devices capable of meeting every need, even in the most complex installations.

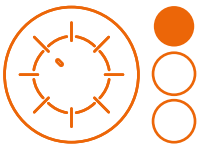

VERSA++

By means of the unique technology of Inim detectors it is possible to configure each detector according to the conditions of the specific ambient in which it will be placed.

By connecting to a line of detectors it is possible to perform for each of them a complete diagnosis, test functionality, check the real-time value reading, view the contamination value of the optical chamber, modify the sensitivity and operating mode.

Each detector has a non-volatile memory which allows you to view the smoke and temperature levels measured in the period prior to the last alarm detected.

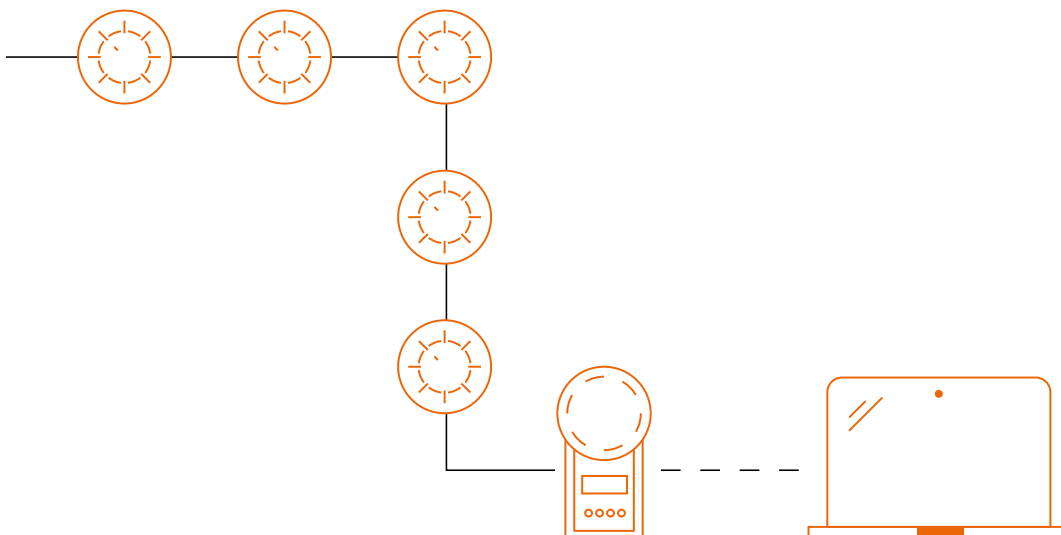



ID100
OPTIC SMOKE DETECTOR

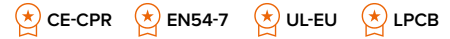

The ID100 optical smoke detector is based on the Tyndall effect (diffusion of light) and provides first-rate early warning in the event of fire. It offers wide-spectrum detection of smoke particles generated by the majority of fires. The newly designed optical chamber with sealed upper-part and 500 µm holes diameter mesh insect screen ensure high immunity to false alarms.

ID100/B Black version

ID200
HEAT DETECTORS



The detector can be set in the following modes: A1R (fixed threshold at 58°C with thermovelocimetric detection), B (fixed threshold at 72°C), A2S (fixed threshold at 58°C), BR (fixed threshold at 72°C with thermovelocimetric detection). As a result of its high flexibility, this detector is suitable for installation in dusty or smoky environments where the risk of false alarms is high.

ID200/B Black version

ID300
SMOKE AND HEAT DETECTORS

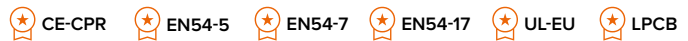

Combines the two systems to achieve increased sensitivity capable of detecting all types of fire (such as flammable liquid fires with low smoke output) and offers a very high false alarm rejection rate. The selectable operating modes settable from the control panel are:

“PLUS” mode: (set at factory) The detector will trigger an alarm when the measured values exceed the set smoke threshold, or when the measured values exceed the set heat threshold. Furthermore, in the event of a rise in temperature, the smoke detection sensitivity will be taken to maximum value.

“OR” mode: The detector will trigger an alarm when the measured values exceed the set smoke threshold, or when the measured values exceed the set heat threshold. This operating mode, characterized by discrete sensitivity analysis, allows the detector to sense fires with a high emission of smoke and low heat output (for example, smouldering fires) and also fires with low emission of smoke and high heat output (for example, burning chemicals).

“AND” mode: The detector will trigger an alarm only when the set smoke and heat thresholds are exceeded at the same time. This operating mode, characterized by low sensitivity, greatly reduces the risk of false alarms. Given the reduced response, it is necessary to evaluate the risk factor before selecting this operating mode.

“SMOKE” mode: The detector will operate as per the ED100.

“HEAT” mode: The detector will operate as per the ED200.

ID300/B Black version

TECHNICAL SPECIFICATIONS

Power supply voltage:	10 - 30 V DC
Standby current consumption	90 µA
Alarm current consumption	Max 40 mA
Settable sensitivity:	0.08 – 0.10 – 0.12 – 0.15 dBm
Operating temperature:	-5° ... +40° C
Height (base included):	54 mm
Diameter:	110 mm
Weight (with base):	160 g
Weight (without base):	90 g

Accessories for smoke and heat detectors



EB0010

Detector base for Iris and Enea series detectors, equipped with short-circuit plate which ensures continuity in the event of removal of the detector from the line.

EB0010B Black version



EB0020

Detector base for Iris and Enea series detectors equipped with a relay activated by the detector.

EB0020B Black version



EB0030

Mounting base for Enea and Iris detectors with pipes entry, 4 knock out for 16 mm pipes. To be installed under the detector base, h 34mm.



EB0040

Base protected against dripping water when tilted up to 15 degrees max.



EB0040H

2 W heater for EB0040 base.



EB0050

EB0010 base spacer, to be installed under the base to create a 10mm gap for the entry of exposed cables.

EB0050B Black version



EB0060

Base for Iris and Enea detectors with integrated buzzer piloted by the 'R' output of the detector. Not compliant with EN54-3 standard.



DD001

This is a cover for unused detectors: it attaches to Inim detector bases, restores line continuity and provides a discrete aesthetic semblance.

Ideal for those applications where bases are installed for the future addition of detectors.



IL0010

Remote alarm signalling LED, directly connectable to the "R" output of addressable or analogue detectors.



EB0010SC

Cable shield connection for EB0010 bases (package of 100 pieces)



Manual call points

A fire detection and alarm system must be equipped with devices for manual alarm activation to be installed along the escape routes. Following is a series of conventional call points for various installation types.

IC0020

MANUAL CALL POINT



Conventional call point for manual activation of alarms. The device trigger element and red status LED are located in the front of the device casing. Once activated the call point can be reset using the reset key included in the package.

- Resettable call point
- Transparent cover for protection against accidental activation, available as an accessory item (WCP0020)
- Deep box for surface wiring duct entry, available as an accessory item (DBCP0020)
- Flange for flush mounting on single gang box, available as an accessory item (FCP0020)

KCP0020

Reset key (pack of 10)

TECHNICAL SPECIFICATIONS

Power supply voltage:	19 - 30 V DC	Temperature:	-10° ... +55° C
Current draw during standby:	0 µA	Dimensions:	84 x 84 x 45 mm
		Dimensions deep base:	33 mm
		Weight:	126 g

ALSO AVAILABLE IN THE FOLLOWING COLOURS (NOT CERTIFIED)

IC0020Y

Manual call point, in yellow

IC0020B

Manual call point, in blue

IC0020G

Manual call point, in green

IC0020W

Manual call point, in white

IC0011E

MANUAL CALL POINT FOR OUTDOOR USE



Call point for activation of alarms, suitable for outdoor use. Once activated the call point can be reset using the reset key included in the package

KEY300

Reset key (pack of 10)

SFT304

Transparent protective plate

EITK2000-ToolKit



See the
online
section

Kit for manual addressing, configuration, maintenance and diagnostics of systems made up of Iris and Enea series devices

EITK2000 is a kit containing:

- **EDRV2000 driver**
- **FireGenius-PRO software**
- **Accessories for the connection and power supply**

The EDRV2000 driver allows fast manual addressing of Enea series addressable-analogue devices in situations where the automatic addressing function provided by Inim control panels is not desired.

The driver is equipped with an “ICP” communication port through which it is possible to connect to fire alarm signalers from the Iris and Enea series and configure their operating parameters (select alarm tones/messages, volume, flasher power, etc.).

Through the driver and the FireGenius-PRO software, it is also possible to customize the tones/messages of the signalers by choosing from the large library available and composing tones to your liking or by starting from audio files.

The kit allows full advantage to be taken of the LoopMap and Versa++ technologies integrated in Enea series addressable analogue detectors. By connecting the EDRV2000 driver to the loop and interfacing it with the FireGenius-PRO software, it is possible to reconstruct the loop wiring map. The various devices connected to the loop are identified by their distinct serial numbers and types. The FireGenius-PRO software is capable of reconstructing the wiring order along the cable and to recognize and trace any ‘T’ junctions that are present. By clicking on the system elements, you will be able to establish the status (smoke level, contamination, etc.) and interact in real-time, for example, by activating LEDs or outputs.

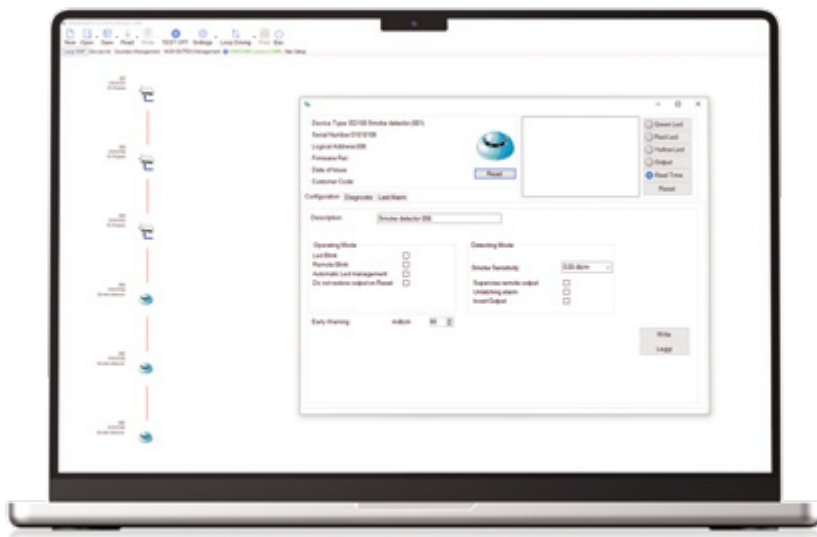



IS2011WE



Visual/Audible alarm indicators



See the online section

Visual/Audible fire alarm devices

One of the roles of primary importance in fire detection systems is covered by audible/visual alarm signalling devices.

Sounders, bells and flashers are some of the most common means of providing warning of fire. Inim offers a wide range of these devices to suit all installation needs.

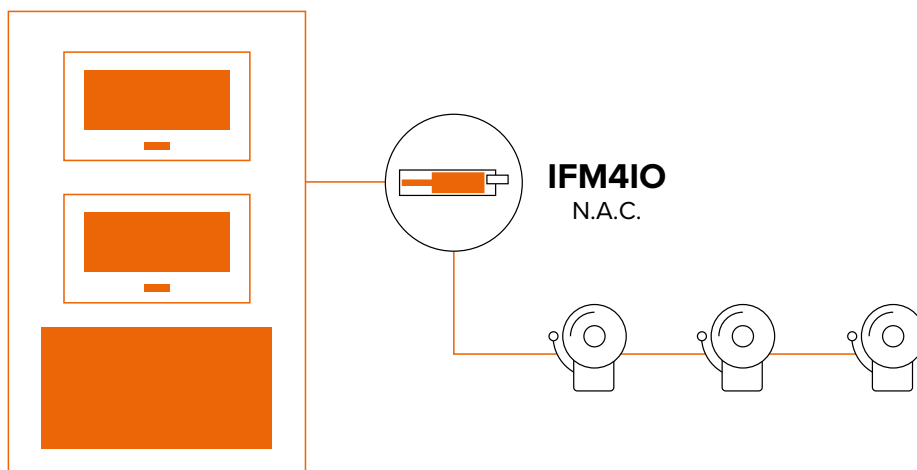



IS2011

WALL MOUNT AUDIBLE ALARM SIGNALLER



The DIP SWITCH allows selection of the alarm tone from the 14 tones available and volume adjustment.

- IS2011RE** Sounder, in red
- IS2011WE** Sounder, in white

IS2021

WALL MOUNT VISUAL/AUDIBLE ALARM SIGNALLER



Visual/Audible alarm signaller, operates at 20 to 30 V DC, IP65 protection grade. The DIP SWITCH allows selection of the alarm tone from the 14 tones available as well as volume and flasher intensity adjustment.

- IS2021RE** Sounder, in red
- IS2021WE** Sounder, in white

IS2030

WALL MOUNT AUDIBLE ALARM SIGNALLER WITH VOICE MESSAGES



The EDRV2000 manual programmer allows selection of the alarm tone or of the voice alarm messages available on-board the device in 8 different languages, as well as volume and the tones/voice messages.

- IS2030RE** Sounder, in red
- IS2030WE** Sounder, in white

IS2050

WALL MOUNT VISUAL/AUDIBLE ALARM SIGNALLER WITH VOICE MESSAGES AND FLASHER



The EDRV2000 manual programmer allows selection of the alarm tone or voice alarm messages available on-board the device in 8 different languages, as well as volume and the tones/voice messages.

- IS2050RE** Sounder, in red
- IS2050WE** Sounder, in white

TECHNICAL SPECIFICATIONS	IS2011	IS2021	IS2030	IS2050
Tone:	14	14	14	14
Voice messages:			16	16
Sound output @ 1 m:	Max. 101 dB			
Current draw:	from 1.4 to 5 mA	from 1.4 to 23 mA	from 10 to 40 mA	from 1.4 to 23 mA
Protection grade:	IP65 (IP21 certified for indoor use)			
Operating voltage	20 - 30 V DC	18 - 30 V DC	18 - 30 V DC	18 - 30 V DC
Visual range in high power:		W-3.5-7, O-3.5-8-7		W-3.5-10.2, O-3.5-10.5-10.0
Visual range in low power:		W-3-6.5, O-3-8-6.5		W-2.8-6.7, O-2.8-7.5-7
Operating temperature:	-10°C ... +55°C			
Dimensions:	121 x 121 x 57 mm			
Weight:	150 g			



PLEXI_ES2000

FRAMED PLEXIGLASS PLATE WITH EMERGENCY INDICATION



Transparent plexiglass plate with "FIRE ALARM" warning (white wording on red background) and Inim Logo. The panel is supplied with assembling kit and template. Dimensions: 430 x 130 x 4 mm.

- PLEXI_ES2000#1DX** ALLARME INCENDIO warning sign with indicating RIGHT
- PLEXI_ES2000#1SX** ALLARME INCENDIO warning sign with indicating LEFT
- PLEXI_ES2000#2DX** FIRE ALARM warning sign with indicating RIGHT
- PLEXI_ES2000#2SX** FIRE ALARM warning sign with indicating LEFT
- PLEXI_ES2000#3DX** EVACUARE IL LOCALE warning sign with indicating RIGHT
- PLEXI_ES2000#3SX** EVACUARE IL LOCALE warning sign with indicating LEFT
- PLEXI_ES2000#4DX** SPEGNIMENTO IN CORSO warning sign with indicating RIGHT
- PLEXI_ES2000#4SX** SPEGNIMENTO IN CORSO warning sign with indicating LEFT
- PLEXI_ES2000#5DX** ALLARME GAS warning sign with indicating RIGHT
- PLEXI_ES2000#5SX** ALLARME GAS warning sign with indicating LEFT

Ceiling mount audible alarm signalers

IS1011

CEILING MOUNT AUDIBLE ALARM SIGNALLER



EN54-3



CE-CPR



The DIP SWITCH allows selection of the alarm tone from the 14 tones available and volume adjustment.

IS1021

CEILING MOUNT VISUAL/AUDIBLE ALARM SIGNALLER



EN54-23



EN54-3



CE-CPR



The DIP SWITCH allows selection of the alarm tone from the 14 tones available, adjustment of the volume and the flasher intensity.

IS1030

CEILING MOUNT AUDIBLE ALARM SIGNALLER WITH VOICE MESSAGES



EN54-3



CE-CPR



The EDRV2000 manual programmer allows selection of the alarm tone or voice alarm messages on-board the device in 8 different languages, as well as volume and the tones/voice messages.



IS2050

CEILING MOUNT VISUAL/AUDIBLE ALARM SIGNALLER WITH VOICE MESSAGES



The EDRV2000 manual programmer allows selection of the alarm tone or voice alarm messages on-board the device in 8 different languages, as well as volume, flasher intensity and the tones/voice messages.

TECHNICAL SPECIFICATIONS	ES2011	ES2021	ES2030	ES2050
Tone:	14	14	14	14
Voice messages:		16	16	16
Sound output @ 1 m:	Max. 98 dB		Max. 101 dB	
Current draw:	from 1.4 to 5 mA	from 1.4 to 23 mA	from 10 to 25 mA	from 10 to 25 mA
Protection grade:				IP21
Operating voltage	18 - 30 V DC		20 - 30 V DC	
Visual range in high power:	W-3.5-7, O-3.5-8-7		W-3.5-10.2, O-3.5-10.5-10.0	
Visual range in low power:	W-3-6.5, O-3-8-6.5		W-2.8-6.7, O-2.8-7.5-7	
Operating temperature:	-10° ... +55° C			
Dimensions:	112 x 112 x 37 mm			
Weight:	155 g			

IS0010

AUDIBLE ALARM SIGNALLER

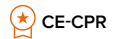

Tone selectable from the 32 available via Dip-Switch, volume adjusted by the internal trimmer.

TECHNICAL SPECIFICATIONS

Tone:	32	Dimensions:	Ø 98 mm h 104 mm
Sound output @ 1 m:	106 dB adjustable up to 86 dB	Dimensions:	Ø 98 mm h 80 mm
Current draw:	from 4 to 41 mA	Weight:	250 g
Protection grade:	IP65 (IP21 low-profile version)		
Operating voltage	17 - 60 V DC		
Operating temperature:	-25°C ... +70°C		

IS0010RE

Audible alarm signaller. Red

IS0010WE

Audible alarm signaller. White

IS0010RES

Audible alarm signaller with low-profile base. Red

IS0010WES

Audible alarm signaller with low-profile base. White



IS0120

CEILING/WALL MOUNT AUDIBLE ALARM SIGNALLER



Optic section approved according new EN54-23 standard, complete with mounting base. Tone selectable from the 32 available by means of DIP switch, flash frequency 0.5Hz / 1Hz (selectable by means of DIP SWITCH), volume selectable from 2 levels.

TECHNICAL SPECIFICATIONS

Tone:	32
Sound output @ 1 m:	97 dB
Current draw:	from 20 to 45 mA
Protection grade:	IP65 (IP21 low-profile version)
Coverage range:	W-3.1-11.3; C-3-15
Operating voltage	17 - 60 V DC

IS0120RE	Red, deep base, wall-mount installation
IS0120RS	Red, low-profile base, wall-mount installation
IS0120REC	Red, deep base, ceiling-mount installation
IS0120RSC	Red, low-profile base, ceiling-mount installation
IS0120WE	White, deep base, wall-mount installation
IS0120WEC	White, deep base, ceiling-mount installation

IS0130

HIGH POWER AUDIBLE ALARM SIGNALLER



Provides 32 tones configurable via DIP SWITCH. The volume is easily adjusted using the internal trimmer.

TECHNICAL SPECIFICATIONS

Tone:	64	Dimensions:	166 x 150 mm
Sound output @ 1 m:	105 / 110 / 120 dB	Weight:	1.8 Kg
Current draw:	from 20 to 45 mA		
Protection grade:	IP66		
Operating voltage	10 - 60 V DC		
Operating temperature:	-25° ... +70° C		

IS0130	120 dB high power audible alarm signaller
IS0131	110 dB high power audible alarm signaller
IS0132	105 dB high power audible alarm signaller



IS0160

HIGH POWER AUDIBLE/VISUAL ALARM SIGNALLER



Provides 64 tones configurable via DIP SWITCH. The volume is easily adjusted using the internal trimmer. LED visual signaller, in red. The devices are classified as either VAD (Visual Alarm Device) or VID (Visual Indication Device) depending on the model.

TECHNICAL SPECIFICATIONS

Tone:	64	Dimensions:	166 x 150 mm
Sound output @ 1 m:	105 / 110 / 120 dB	Weight:	1.8 Kg
Current draw:	from 18 mA to 65 mA		
Protection grade:	IP66		
Coverage range:	W-3.1-11.3; C-3-15		
Operating voltage	10 - 60 V DC		
Operating temperature:	-25° ... +70° C		

- IS0160** 120 dB high power visual/audible alarm signaller
Optic section not certified EN 54-23 (VID)
- IS0161** 110 dB high power visual/audible alarm signaller
Optic section not certified EN 54-23 (VID)
- IS0162** 105 dB high power visual/audible alarm signaller
Optic section not certified EN 54-23 (VID)
- IS0163** 105 dB high power visual/audible alarm signaller
Optic section certified EN54-23 White Flash light
- IS0164** 110 dB high power visual/audible alarm signaller
Optic section certified EN54-23 White Flash light
- IS0165** 105 dB high power visual/audible alarm signaller
Optic section certified EN54-23 Red Flash light
- IS0166** 110 dB high power visual/audible alarm signaller
Optic section certified EN54-23 Red Flash light

ISC010 / ISC010E

6" BELL



- ISC010** Motorized bell operates at 19 to 28 V DC, low current consumption.
- ISC010E** Motorized bell operates at 19 to 28 V DC, low current consumption, for outdoor installation.

TECHNICAL SPECIFICATIONS

Sound output @ 1 m:	95 dB	Dimensions:	160 x 64 mm
Current draw:	from 20 mA	Weight:	920 g
Protection grade:	IP21 (indoor installation) IP33 (outdoor installation)		
Operating temperature:	-10° ... +55° C		

SMARTY-GFR

VISUAL AUDIBLE ALARM SIGNALLER. RED



Equipped with piezoelectric sounder and super bright LED technology flasher.

TECHNICAL SPECIFICATIONS

Sound output @ 1 m:	105 dB	Dimensions:	75 x 112 x 30 mm
Current draw:	Max 50 mA	Weight:	110 gr
Protection grade:	IP31		
Light intensity:	25 lux		
Power supply voltage:	24 V DC		
Operating temperature:	-0°C ... +50°C		



ISS021 - ISS022

VISUAL/AUDIBLE ALARM SIGN



Red alarm sign complete with EN54-3 certified audible signalling. The ISS021 version is classified as a VID (Visual Indication Device) and is NOT certified for the visual part according to the EN54-23 standard. The ISS022 version is classified as a VAD (Visual Alarm Device) and includes an EN54-23 certified high power visual signaller. Comes with "Fire alarm" written on it, available with different indications on request.



TECHNICAL SPECIFICATIONS	IS2011	IS2021
Sound output @ 1 m:		92 dB(A)
Light output	EN54-23 W 4,6 - 9,1	
Flash frequency	1 Hz	
Operating voltage	11 - 30 V DC	18 - 30 V DC
Current draw	50 mA	21 mA (media)
Operating temperature:		-10° ... +55° C

- ISS021 - ITA** Visual/Audible sign indicating "fire alarm"
- ISS022- ITA** Visual/Audible sign with flasher indicating "fire alarm"
- ISS021 - ENG** Visual/Audible sign indicating "fire alarm"
- ISS022- ENG** Visual/Audible sign with flasher indicating "fire alarm"

PICTOGRAMS (PACK OF 10 PIECES)

- FOP45** Fire alarm
- FOP46** Door alarm
- FOP47** Spegnimento in corso
- FOP48** Evacuare il locale
- FOP49** Allarme gas
- FOP36** Fire do not enter
- FOP37** Extincion disparada
- FOP38** Gas discharge
- FOP39** Fuego
- FOP34** Presenza acetilene
- FOP35** Carenza ossigeno

IVY-R

SELF-POWERED SOUNDER/FLASHER FOR OUTDOOR INSTALLATION



If combined with fire-fighting systems operating at 24V, it requires voltage reducer model STD241201. Houses 12 V 2 Ah battery (not supplied).

TECHNICAL SPECIFICATIONS			
Sound output @ 3 m:	103 dB	Dimensions:	288 x 207 x 107 mm
Power supply voltage:	12 V DC	Weight:	2.7 Kg
Protection grade:	IP34		



F-COM

 EN54-4  EN54-21  CE-CPR

Universal telephone communicator for fire detection systems



As required by the reference legislation, all unmanned fire detection and alarm systems (IRAI) must be equipped with a remote communicator CERTIFIED EN54-21.

The F-COM universal communicator, thanks to its flexibility and configuration simplicity, is capable of sending voice calls in response to the activation of its input lines (it includes a memory for voice messages configurable via audio recorder or text-to-speech converter), as well as digital calls via the most widely used communication protocols and SMS texts.

Thanks to the graphic display and the intuitive user interface, the F-COM communicator is simple to use, effective and adapts to any control panel of any brand and model. F-COM is capable of remotely transmitting any type of alarm condition, fault and is freely configurable via hardwired Telephone line, GSM Line or 3G data line. The communicator has its own internal EN54-4 certified power supply, houses two 12 V 1.2 Ah batteries (not supplied).

TECHNICAL SPECIFICATIONS

Power supply voltage:	230 V AC	Dimensions:	260 x 200 x 55 mm
Current draw:	Max 0.5 A	Weight:	1500 gr
Protection grade:	IP30		
Output voltage:	27.6 V DC		
Batteries:	2 x 12 V, 1.3 Ah		
Operating temperature:	-5° C ... +40° C		
Classification in accordance with EN 54-21:	Type 2		



F-COM/STUDIO



See the
online
section

Configuration and diagnostics software for F-COM universal communicator

Via the F-COM Studio software, it is possible to easily and completely configure the universal communicators for fire detection and alarm systems of the F-COM series. Made available to the operator is a section in which to configure voice messages using audio files or the text to speech converter, a database for customer management and a diagnostic section where it is possible check the status of the communicator in detail.

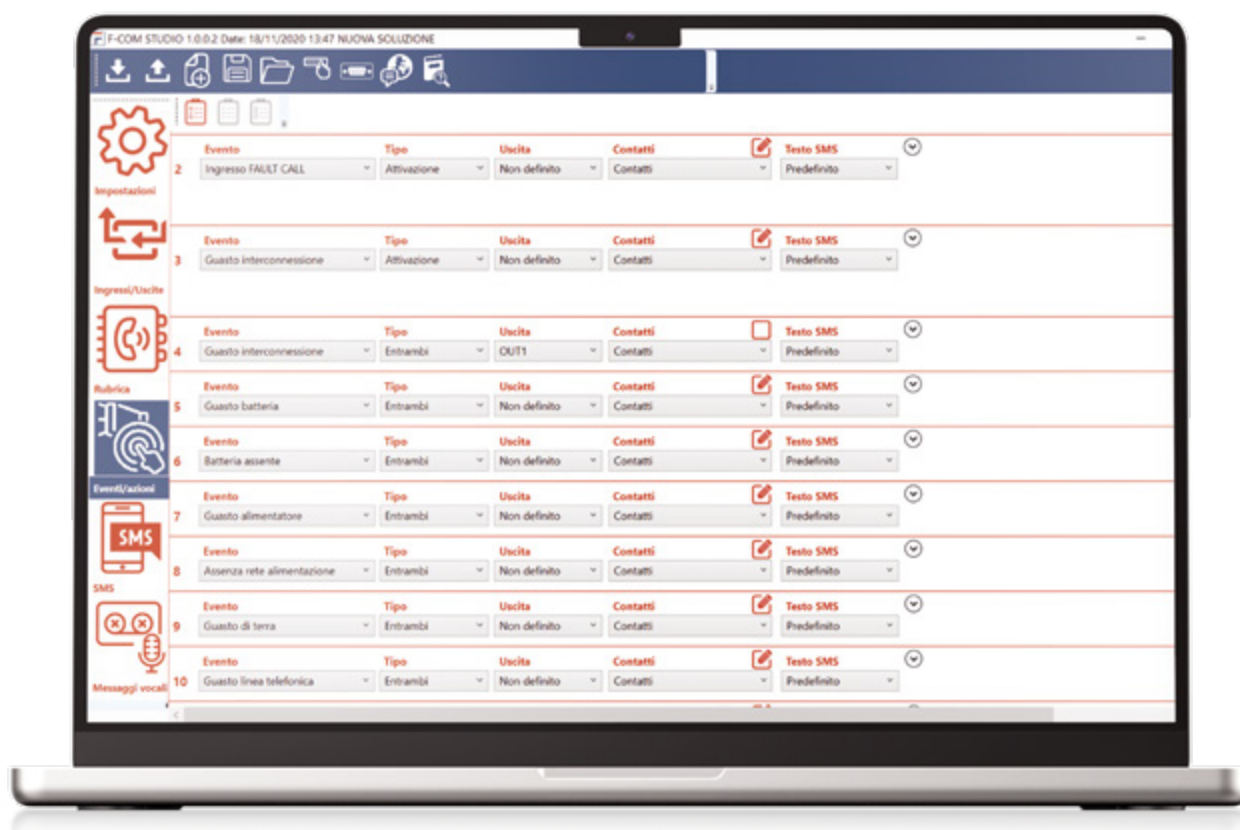





Aspirating smoke detectors



See the
online
section

Advanced systems based on continuous aspiration of air from the protected ambient

Aspirating smoke detection systems, thanks to their sensitivity and the possibility of installation outside the area to be sampled and the possibility of adding filters and condensate traps, lend themselves to a series of applications in which the installation of detectors with different technologies would be difficult.

Inim offers a range of detectors with unique characteristics that can be connected directly to addressable control panels for fully centralized control.

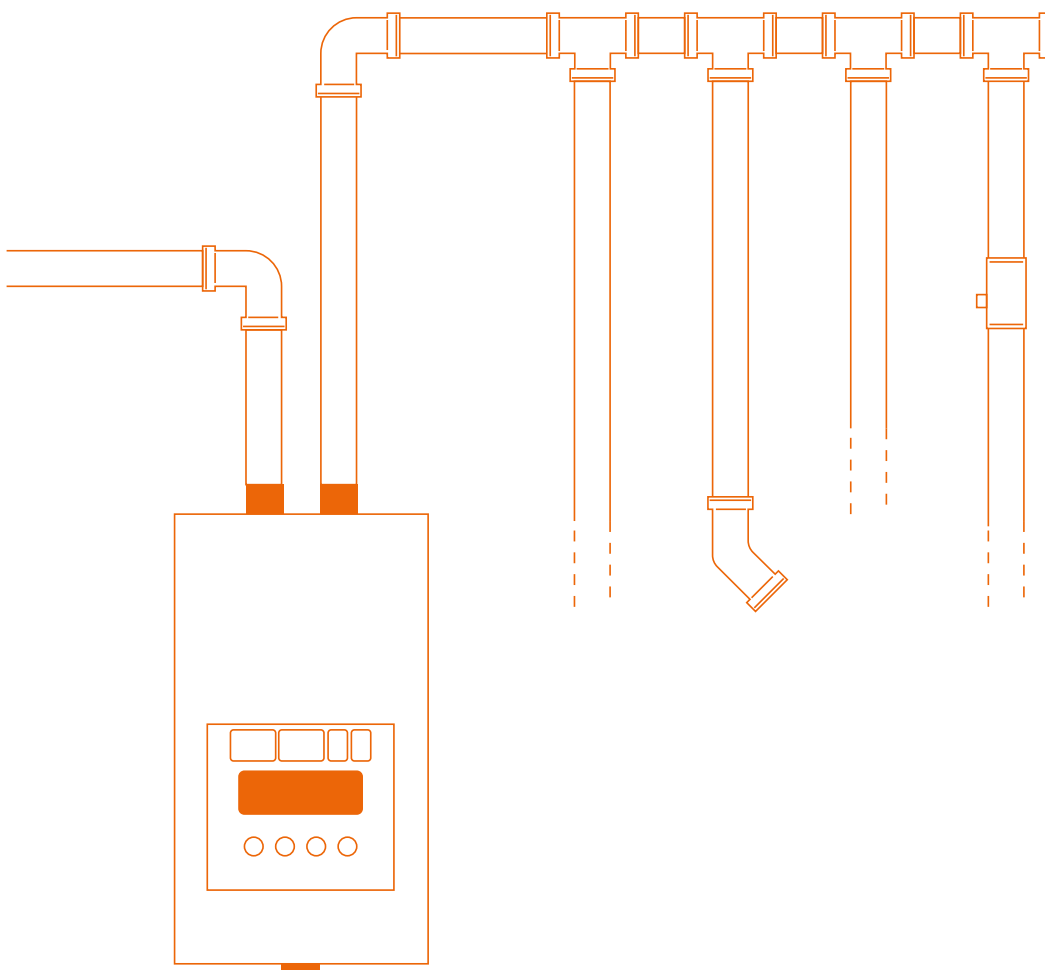



FA100

AVAILABLE FROM
SEPTEMBER 2023

Smoke detector and aspirator

The two channels are completely independent except for the aspirating fan which they share. Each of the two sampling pipes (channels) can be configured independently in class A, B or C, can reach a maximum distance of 100m and can support a number of sampling holes equal to 8 in class A, 16 in class B, 50 in class C.

The sampling modules are based on dual light technology that uses two distinct light sources (infrared and blue) capable of evaluating the size of the detected particles and of providing a prompt response in the event of an outbreak of fire whilst offering a high rejection of false alarms caused by dust or mist. Each of the detector modules is capable of measuring the flow rate of the aspirated air and of signalling a fault if this deviates from the value set when activating the system (clogged sampling holes or breaks in the sampling duct).

The detector can be connected to Inim addressable fire control panels by connecting it directly to the loop (the power supply voltage must be supplied separately) thus transferring all the signals and control to the control panel, or it can be connected to any control panel, even conventional, thanks to its relay outputs (6) and its I/O terminals (4).

FA100-1
FA100-2

Single channel version
Dual channel version





Expandable channels

Aspirating smoke detection systems with one or two channels.

Independent channels

Independent channels with shared suction fan

Flexible

Interchangeable internal detectors.

Advanced technology

Technology of dual light detectors for the identification of the particle dimensions.

Instant

Immediate response to the start of fire and high false alarm rejection.

Configurable detector

Each detector configurable in class A, B or C as per EN54-20 standard.





FA Studio

Sizing and configuration software for FA100

The FA-STUDIO software, downloadable from the Inim website, allows both the design and sizing of the network of aspirating pipes of the FA-100 system as well as the configuration and putting in service of the installed devices.

The design section, based on a 3D CAD system, allows the importation of Autocad files on which it is possible to draw the aspirating pipe network. The software assists the designer by indicating the areas of coverage of each hole and of any limits and constraints.

Once the sampling network has been designed, the software performs the fluid dynamics calculations specifying the diameter of each hole, the parameters to be set on the device and indicating the sensitivity and transport time of each sampling point.

A practical customizable list of materials is generated in order to allow the forwarding of the order.

The FA-STUDIO software includes the configuration functions of the FA-100 devices which allow adjustment and customization of all the system parameters.

Finally, a series of essential diagnostic functions allows the verification of the system parameters in real time and access to the detector memory containing all the values (Smoke, flow, temperature, etc.) sampled every few seconds over the last 3 months of operation, all the events (alarms, faults, etc.) detected are highlighted on these diagrams.

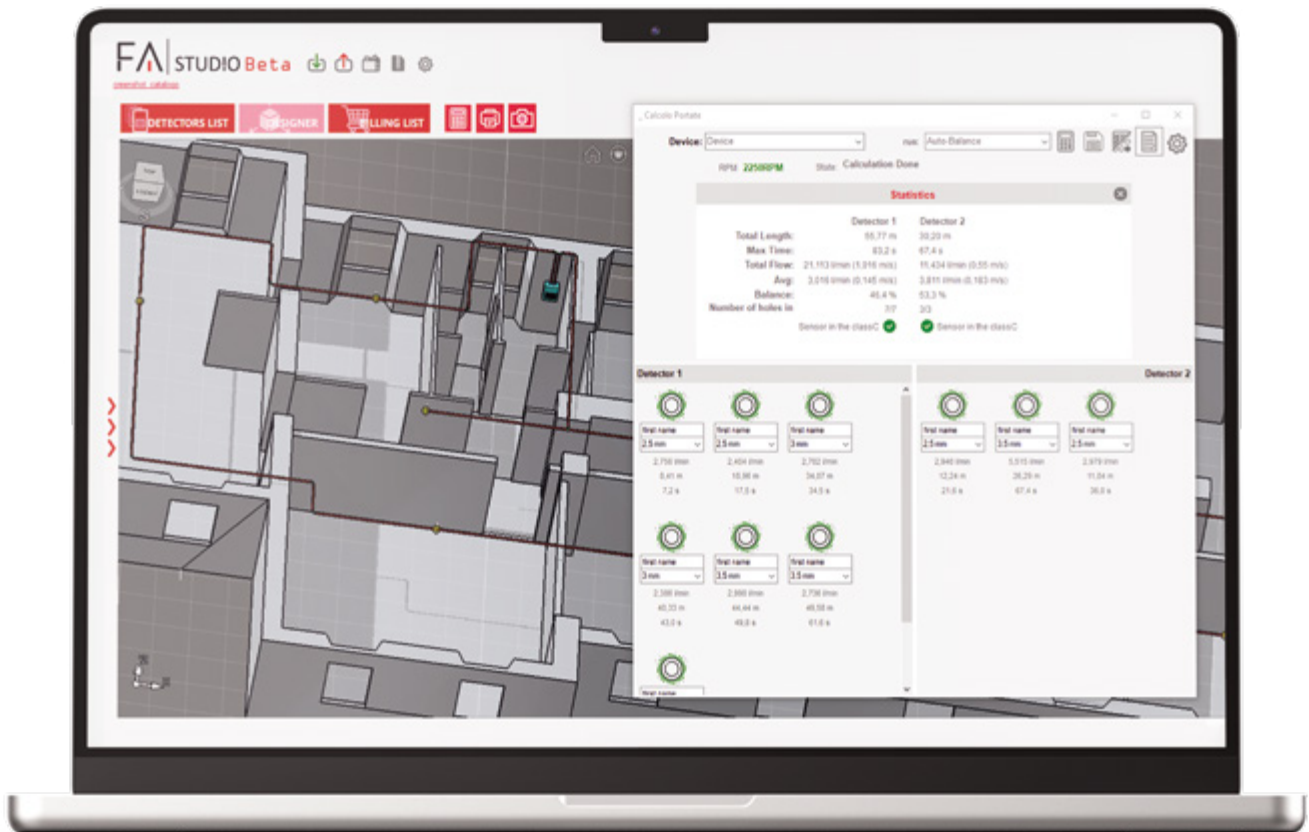



Stratos

The aspirating smoke detectors of the STRATOS series offer a wide range of solutions for ambients of different types and dimensions. Based on laser detectors they ensure timely and reliable detection.

IN30725

MICRA 10 ASPIRATING SMOKE DETECTOR

CE-CPR EN54-20



The highly reliable Micra 10 is a compact, installation-friendly aspiration system capable of detecting smoke at the incipient stage of fire. The 'Classifire' algorithm implemented inside is capable of automatically optimizing the sensitivity of the detector to suit the environment where it is installed, thus eliminating the need for complex calibration operations. Thanks to its output relays (dry contacts) this device is compatible with all fire detection system.

IN30671

MICRA 25 ASPIRATING SMOKE DETECTOR

CE-CPR EN54-20



Micra 25 maintains all the distinctive features of Stratos (ClassiFire® Perceptive Artificial Intelligence Dual TechnologyLDD 3D3). Micra 25 is the most cost-efficient way of creating a laser-based aspirating system. In fact, it is capable of drawing air from the protected area through a sampling pipe of up to 50 m long. Micra 25 is suitable for installation in small applications or rooms which require individual incipient fire reporting.

IN30672

MICRA 100 ASPIRATING SMOKE DETECTOR

CE-CPR EN54-20



Micra 100 is suitable for small to medium applications. It is capable of drawing air from the protected area through two sampling pipes for a total length of 100mt.

N30436

Relay board for Stratos Micra

IN30755

Dust filter for Stratos Micra

TECHNICAL SPECIFICATIONS	MICRA 10	MICRA 25	MICRA 100
Power supply voltage:		21.6 - 26.4 V DC	
Current draw:	Max 250 mA @ 24 V		Max 400 mA @ 24 V
Operating temperature:		-10° ... +60° C	
Humidity:		0 - 90% non condensing	
Maximum pipe length:	50 m		100 m
Sampling pipe diameter:		3/4" (27 mm Ø external)	
Pipe inlet:	1		2
Exhaust pipe to expel the sampled air:		1	
Maximum number of sampling holes:	10		25
Detection levels:		Alarm, Early warning	
On-board relays:		Early warning, Alarm, Fault	
Protection grade:		IP50	
Dimension:	220 x 144 x 90 mm		300 x 220 x 85 mm
Weight:	1.7 Kg		3.8 Kg



STRATOS HSSD2
ASPIRATING SMOKE DETECTOR



Stratos HSSD is capable of drawing air from the protected area through four sampling pipes of up to 100mt each, for a maximum total length of 200mt. It is equipped with keypad and display and provides information regarding system operating status and eventual alarm conditions.

- IN30621** Aspirating system HSSD 2
- IN30699** Dust filter for Stratos HSSD2

TECHNICAL SPECIFICATIONS

Power supply voltage:	21.6 - 26.4 V DC	Dimension:	427 x 372 x 95 mm
Current draw:	Max. 450 mA @ 24 V	Weight:	5.2 Kg
Operating temperature:	-10° ... +60° C	Protection grade:	IP50
Humidity:	0 - 90% non condensing		
Maximum pipe length:	100 m		
Sampling pipe diameter:	3/4" (27 mm Ø external)		
Pipe inlet:	4		
Exhaust pipe to expel the sampled air	1		
Maximum number of sampling holes:	100		
Detection levels:	Alarm, Early warning		
On-board relays:	Early warning, Alarm, Fault		

STRATOS MODULASEAR
ASPIRATING SMOKE DETECTOR



ModuLaser is a scalable and modular aspirating smoke detector. The detector is based on a control module available in three versions: Standard with TFT colour display, status LEDs and navigation buttons; Minimo with only status LEDs and Command which is similar to Standard but with the added capability to control various modules on SenseNET. A maximum of 8 detector modules can be combined with the control module, each detector module can accommodate up to 250 meters of combined sampling pipe.

- 9-30780** Stratos ModuLaser - Minimum display module
- 9-30781** Stratos ModuLaser - TFT display module
- 9-30782** Stratos ModuLaser - Command module
- 9-30783** Stratos ModuLaser - Detector module

TECHNICAL SPECIFICATIONS

Power supply voltage:	18 - 30 V DC	Dimension:	300 x 135 x 110 mm
Current draw:	Max. 940 mA @ 24 V	Weight:	1.5 Kg
Operating temperature:	-10° ... +60° C	Protection grade:	IP50
Humidity:	0 - 90% non condensing		
Maximum pipe length:	150 m		
Sampling pipe diameter:	3/4" (27 mm Ø external)		
Pipe inlet:	4		
Exhaust pipe to expel the sampled air	1		
Maximum number of sampling holes:	20 (A) / 40 (B) / 50 (C)		
Detection levels:	Alarm, Early warning		
On-board relays:	Early warning, Alarm, Fault		

Sampling pipes for aspirating systems

EN61386 -1

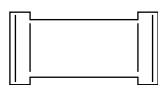

TUBOABS0250M

25 mm external Ø pipe
3 m bar
25 bars package



SASO100250RS

Coupling sleeve
external Ø 25 mm
10 pcs package

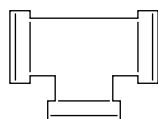

SATE400250RS

T-derivation
external Ø 25 mm
10 pcs package

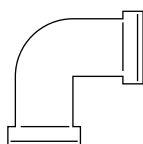

SABE300250RS

90° bend
external Ø 25mm (large radius), 10 pcs package

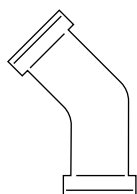

SAEY500250RS

45° Elbow
external Ø 25 mm
10 pcs package



SACA700250RS

Pipe end cap
external Ø 25 mm
10 pcs package

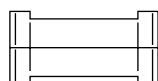

SAUN800250RS

Openable joint sleeve
external Ø 25 mm
10 pcs package



STS25REDK

Hose clip
external Ø 25 mm
50 pcs package



SGLUEN0250 / SGLUEN0500

Sealing glue
250 ml or 500 ml package



17250019050

Flexible spiral pipe
external Ø 25 mm
10 m roll

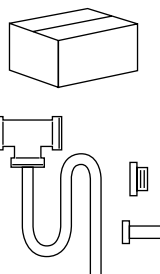

CAPKIT2510SR

Kit for the creation of a sampling capillary comprising:
"T"-derivation for 25 mm external Ø pipes with derivation for pipes

external Ø 10 mm
- 1 d.3/8" x 28 - L.35 mm bulkhead
internal Ø 10 mm
- 1 d.3/8"G gasket



MPE1008025M-R

Red Flexible pipe
external Ø 10 mm
for sampling capillaries
25 m roll

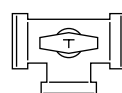

2510025

3-way ball valve
pvc/epdm for pipes
external Ø 25 mm

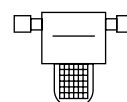

504F075ABS

Medium F0.75 filter holder, 3/4" threaded connections, complete with RL5 cartridge. 2 fittings required (AAD12025CRS), to be purchased separately.



AAD12025CRS

Male/Female fitting
from 3/4"G to 25 m
Necessary to adapt the 504F075ABS filter to 25 mm external Ø pipes



ASO15025CRS

Sleeve for 3/4" pipe fitting with 25 mm external Ø pipes.

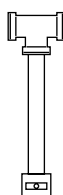

WT025

Condensate trap for applications in which the sampled environment is particularly cold compared to the environment where the detector is installed. Includes the "T"-derivation, valve and collection tube.

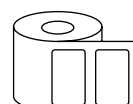

LABEL23X10

Roll of 200 sampling point labels with written: ASPIRATING POINT





Special detection



See the
online
section

Optical linear smoke detectors

Linear smoke detectors are a widely used solution in applications characterized by large open places (sheds, large commercial premises, hangars, etc.). The use of trans-reflective detectors such as those proposed, which require wiring only from one end of the protected area, are further advantageous as they make it possible to reduce installation and maintenance costs without detracting from their reliability and effectiveness.





BDH160

SELF-ALIGNING OPTICAL BEAM SMOKE DETECTOR



CE - CPR



EN54-12



Equipped with transreflective technology and a motorized head capable of aligning itself automatically during the commissioning phase and also of re-aligning itself during service. The system comprises a motorized head unit containing an infra-red transmitter and receiver, a ground level controller and prism reflector. The system includes a motorized head containing an infrared transceiver, a ground level controller and reflectors. The presence of smoke is revealed by the analysis of the infrared beam transmitted by the head and reflected by the reflector. The standard system covers a distance from 5 to 70m. Kits (additional reflectors) are available in order to increase the range to a maximum of 160m.

- Detector with integrated TX and RX and reflector
- Motorized for self-alignment
- Connectable to Inim Loop via EU311 module
- Powered independently or from Loop
- Max. 20 Detectors powered from single Loop (to be verified with Loop calculation software)
- Controller for surveillance and maintenance operations

TECHNICAL SPECIFICATIONS

Stand-by current draw:	3 mA	Protection grade:	IP65
Current draw during alarm status:	3 mA	Dimension:	155 x 180 x 125 mm
Operating temperature:	-15° ... +55° C	Weight:	1 Kg
Operating voltage	10.2 / 30 V		

BDH200

SELF-ALIGNING OPTICAL BEAM SMOKE DETECTOR WITH BLUETOOTH AND MANAGEMENT APP



CE - CPR



EN54-12



Functions and features identical to the BDH160, this model includes a Bluetooth interface and an App for managing and controlling the detector.

- Detector with integrated TX and RX and reflector
- Motorized for self-alignment
- Connectable to Inim Loop via EU311 module
- Powered independently or from Loop
- Max. 20 Detectors powered from single Loop (to be verified with Loop calculation software)
- BlueTooth interface for connection with SmartPhone
- Free App for detector control

TECHNICAL SPECIFICATIONS

Stand-by current draw:	3 mA	Protection grade:	IP65
Current draw during alarm status:	3 mA	Dimension:	155 x 180 x 125 mm
Operating temperature:	-15° ... +55° C	Weight:	1 Kg
Operating voltage	10.2 / 30 V		



Download
the App from
the Android
store



Download
the App from
the Android
store



Accessories for BDH linear smoke detectors



70KIT140

70 TO 140M EXTENSION KIT

Includes a mounting plate for BDH-ADAPT reflectors and 3 additional reflectors.

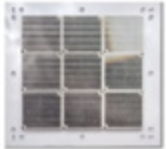

140KIT160

70 TO 160M EXTENSION KIT

Includes a mounting plate for BDH-ADAPT reflectors and 8 additional reflectors.



BDHADAPT

PLATE FOR ASSEMBLING THE DETECTOR OR REFLECTORS

Already supplied with the range extension kit, facilitates detector mounting in situations where a suitable wall is not available (metal mesh, uneven surface, etc.).



FB-BRACKET

SWIVEL PLATE FOR PRISM REFLECTOR

Allows the correct alignment of the reflector and the transmitter in the event the two objects are not installed facing each other.



FOGKIT

ANTI-FOGGING KIT FOR APPLICATIONS IN PARTICULARLY HUMID AMBIENTS

The Kit includes a screen in anti-fogging material to be applied on the transceiver and a single reflector (FOGREF) in anti-fogging material.



FOGREF

REFLECTOR IN ANTI-FOGGING MATERIAL

To be combined with FOGKIT for applications with ranges exceeding 70m.



EDB01

MANUAL ALIGNING OPTICAL LINEAR SMOKE DETECTOR WITH BLUETOOTH AND APP

 CE - CPR  EN54-12



Characterized by low cost and ease of installation. The detector covers a distance from 10m to 100m (up to 50m with a single reflector, up to 100m with 4 reflectors, supplied in the package), thanks to its alarm and fault relays it can be connected to any control panel or directly the Inim Loop Inim via an EU311 module. In the case of connection to the loop it is possible to take power from the loop itself ,up to a maximum of 5 detectors per loop (to be verified with Loop sizing software).

Alignment is facilitated by the laser included in the device which allows adjustment of the deflection mechanism and verification of the exact point where the beam is pointing.

Using the internal DIP SWITCH it is possible to set the sensitivity of the detector and select between the self-resetting or alarm latching mode.

A free App is available in the stores for Android and iOS SmartPhones which, thanks to the Bluetooth interface included in the device, allows real-time remote control of the detector.

- Manual alignment via laser pointer
- Connectable to Inim Loop via EU311 module
- Powered independently or from Loop
- Max. 5 detectors powered by a single Loop (to be verified with Loop calculation software)
- Bluetooth interface for connection with SmartPhone
- Free App for detector control

TECHNICAL SPECIFICATIONS

Stand-by current draw:	20 mA	Dimension:	172 x 110 x 81 mm
Current draw during alarm status:	20 - 40 mA	Weight:	350 gr
Operating temperature:	-10° ... +55° C		
Operating voltage	12 / 30 V		

Adaptors for duct applications

The detection of the presence of smoke inside ventilation ducts, as recognized by international standards, is essential to avoid the transfer of fumes and toxic gases from one part of the building to another which would greatly increase the risk for the occupants.

The items shown in this section allow point smoke detectors to be adapted for this purpose, detection that would not be possible by installing the detector directly inside the duct due to the excessive speed of the air flow inside it.

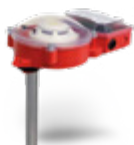

EBDDHN UNIVERSAL ADAPTER FOR DUCT INSTALLATION

Houses all types of detector (analogue or conventional). The detector base (not included) fits inside and is secured firmly in place by means of two screws (included). A practical terminal board makes wiring easy. It provides early warning of smoke by continually sampling air movement within heating and ventilation ducts in industrial and commercial buildings. Based on the Venturi principle, this device has been designed to operate with an optical smoke detector and adequate length air sampling tube. It operates at an air velocity of between 0.5m/s to 20m/s.

TECHNICAL SPECIFICATIONS

Sampling tube length:	0.6-1.5-2.8 m	Dimension:	180 x 183 x 235 mm
Air velocity:	0.5/20 ms	Weight:	700 g



TV06N / TV15N / TV28N SAMPLING PIPE

The air-sampling pipe is available in three different lengths: 0.6 m, 1.5 m, 2.8 m. It should be chosen in accordance with the width of the duct concerned. The sampling pipe must pass through at least 90% of the duct. If the duct is wider than 60cm, the sampling pipe must pass through the entire duct.

Installation: the aluminium sampling tube can be easily shortened to adapt to the duct. The diameter of the hole for the air-sampling tube is 38 mm.

The adaptor is fitted with a red plastic tongue which indicates the air flow to the detector and thus confirms that air flow from the duct is passing through properly.



DDHBRKTN MOUNTING BRACKET

This device fits to circular ducts and provides a flat mounting surface for the EBDDHN.



DDHCOVER WEATHERPROOF COVER

Watertight cover for item EBDDHN in the case of outdoor installation.



DDH204 SET OF SPARE GASKETS ON



DDH F1/10 N ANTI-DUST FILTER



Flame detectors

These are capable of detecting the radiations emitted by open flames in the infrared and ultraviolet spectrum, they are suitable for monitoring all those sources of danger where flames might be released (pipes, junction points, warehouses containing flammable materials, etc.). The choice of the type of detector must be made taking into account the type of flame to be detected (verification of the correspondence between the radiations emitted by the flame to be detected and those revealed by the detector) and the size of the flame which might be released (positioning and distance of the flame detector with respect to the area to be protected).

TALENTUM IR2 SERIES FLAME DETECTORS

IR² FLAME DETECTOR WITH DUAL INFRARED SENSOR



Flame detectors capable of detecting infrared radiation in two different bands, they are able to discriminate the radiation of a flame with respect to radiation from other sources. Relay output.



016581

FLAME DETECTOR WITH DUAL INFRARED BAND FOR INDOOR USE

Flame detector with dual infrared band for indoor use



016571

FLAME DETECTOR WITH DUAL INFRARED BAND. FOR INDOOR USE

ATEX certified Intrinsically Safe
ATEX: II 1 G - Ga Ex ia IIC T4



016511

IR² FLAME DETECTOR IN EXPLOSION-PROOF ENCLOSURE

Flame detector with dual infrared band. ATEX certified in flame-proof enclosure. ATEX: II 2 G D - Ex d IIC T4 Gb - Ex d IIIC T135°C Db IP66 A21

TALENTUM IR3 SERIES FLAME DETECTORS

IR³ DUAL INFRARED FLAME DETECTOR



Flame detectors capable of detecting infrared radiation in three different bands, they are able to discriminate the radiation of a flame with respect to radiation from other sources. Relay output.



016589

IR³ FLAME DETECTOR

Triple infrared band flame detector. For indoor use. Excellent immunity to false alarms



016579

IR³ FLAME DETECTOR INTRINSECALLY SAFE

Triple infrared band flame detector. For indoor use. Excellent immunity to false alarms. ATEX Intrinsically Safe. ATEX: II 1 G Ga Ex ia IIC T4



016519

IR³ FLAME DETECTOR IN EXPLOSION-PROOF ENCLOSURE

Excellent immunity to false alarms. ATEX certified in explosion-proof enclosure. ATEX: II 2 G D - Ex d IIC T4 Gb - Ex d IIIC T135°C Db IP66 A21

TALENTUM UV/IR² SERIES FLAME DETECTORS

FLAME DETECTOR WITH UV SENSOR AND DUAL INFRARED SENSOR

CE - CPR EN54-10

Flame detectors capable of detecting infrared radiation in two different bands as well as ultraviolet radiation, they are able to discriminate the radiation of a flame with respect to radiation from other sources. Relay output.



016591

FLAME DETECTOR WITH DUAL INFRARED BAND AND ULTRAVIOLET DETECTOR

Flame detector with dual infrared band and ultraviolet detector. For indoor use. Maximum immunity to false alarms



016521

IR² FLAME DETECTOR IN EXPLOSION-PROOF ENCLOSURE

Flame detector with dual infrared band and ultraviolet detector. Maximum immunity to false alarms. ATEX certified in flame-proof enclosure. ATEX:- II 2 G D
Ex d IIC T4 Gb - Ex d IIIC T135°C Db IP66 A21

TECHNICAL SPECIFICATIONS	IR2	IR3	UV/IR2
Power supply voltage:		14 - 30 V dc	
Current draw:		from 8 to 28 mA	
IP class:		IP 65	
Range of View:		0.1m ² n-heptane at 25 m	
Sensitivity:		Class 1 (EN54-10)	
Coverage angle:		90° cone	
Response spectrum:	IR ² 0.75 to 2.7 μm	IR ³ 0.75 to 2.7 μm	UV 185 to 260nm / IR ² 1.0 to 2.7 μm
Operating temperature:		-10° C ...+ 55° C	

Accessories for Talentum series flame detectors



007127

SWIVEL MOUNTING BRACKET



012545

STEEL COVER FOR FLAME DETECTORS



007279

STEEL COVER FOR FLAME DETECTORS IN EXPLOSION-PROOF CASING



16091

TESTER FOR FLAME DETECTORS

Simulator for flame detectors Portable with rechargeable batteries, battery holder included.
Wide output spectrum, UV, Visible, IR, Mid-IR
Selectable output: Constant flash, regular, irregular flicker
Includes a carrying case.



SENSEWARE SERIES FLAME DETECTORS

FLAME DETECTORS



Detectors suitable for detecting flames from light and heavy hydrocarbons (wood, paper, oil, natural gas) and flames generated by hydrogen (for UV and UV/IR models). 90° vision cone, good immunity to false stimuli. 10-28V DC power supply, IP65 Protection Grade, all models have the following certificates: EN54-10, ATEX/IECEx cat. 3 for use in 2/22 zones, FM, Class 3260 and cFmus class 3611.



IR3-109/1

IR³ FLAME DETECTOR

Flame detector with three IR detectors. For indoor and outdoor use. Suitable for type 2 ATEX zones. Case in GRP (fiberglass) Swivel bracket not supplied (SM21)



UV-185/5

UV FLAME DETECTOR

Ultraviolet flame detector. For indoor and outdoor use. Suitable for type 2 ATEX zones. Case in GRP (fiberglass) Swivel bracket not supplied (SM21)



UV/IR-210/1

UV/IR FLAME DETECTOR

Ultraviolet and infrared flame detector. For indoor and outdoor use. Suitable for type 2 ATEX zones. Case in GRP (fiberglass) Swivel bracket not supplied (SM21)

TECHNICAL SPECIFICATIONS	IR3	UV	UV/IR
Power supply voltage:		from 10 - 28 V DC	
Current draw:		from 25 to 40 mA	
IP class:		IP 65	
Range of View:	0.09m ² n-heptane at 35 m		0.09m ² n-heptane at 23 m
Sensitivity:	Class 1 (EN54-10)		Class 2 (EN54-10)
Coverage angle:		90° cone	
Response spectrum:	2.7 to 5 μm	185 - 260 μm	185 - 260 nm / IR: 2.7 μm
Operating temperature:		-25° ... + 70° C	

Accessories for Senseware series flame detectors



SM21

ARTICULATED SUPPORT IN PA66 POLYAMIDE



TC-169/1

NON-EX CERTIFIED TEST LAMP WITH RECHARGEABLE BATTERIES, INCLUDING BATTERY CHARGER AND CASE



TC-940/1Z

INTRINSICALLY SAFE TEST LAMP, IECEx/ATEX CERTIFIED



IP66 Heat detectors

Heat detectors with IP66 Protection Grade for applications in particularly hazardous ambients.

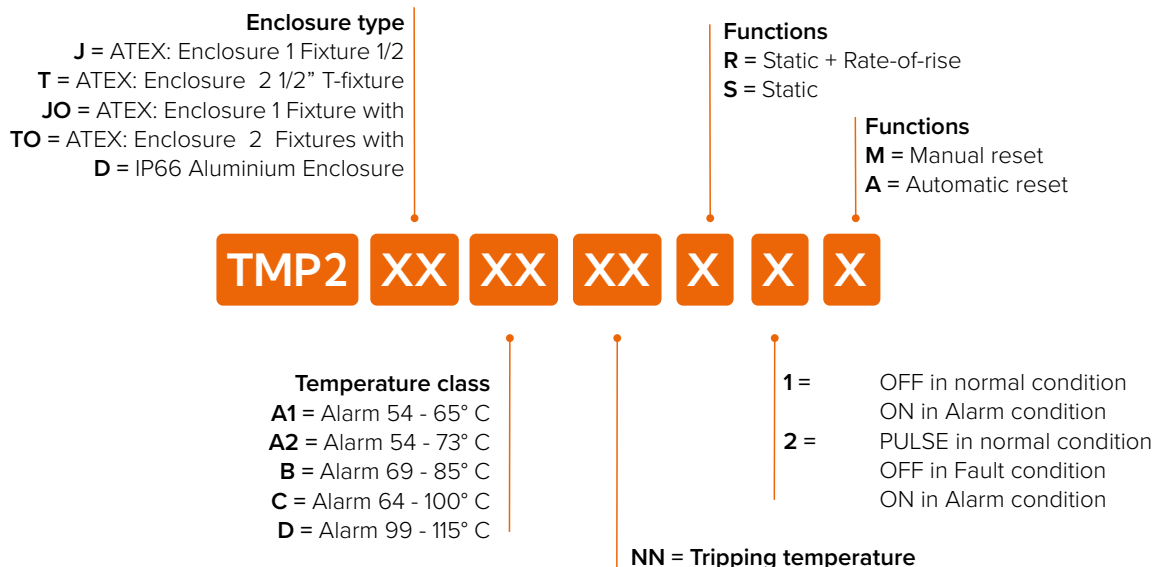

TMP2-D HEAT DETECTORS

CE - CPR EN54-5



Absorption temperature sensor (for conventional control panels) TMP2-D series, aluminum enclosure with IP66 Protection Grade. 2 top cable entries, 2 M20 cable glands included. Automatic reset.

TECHNICAL SPECIFICATIONS

Power supply voltage:	12 - 24 V DC	IP class:	IP66
Stand-by current draw:	30 µA	Dimensions:	203 x 95 x 60 mm
Current draw during alarm status:	11 mA @ 13.7 V / 12 mA @ 24 V	Weight:	400 g
Operating temperature:	-20° ... 135° C		

TMP2-J IP66 ATEX TEMPERATURE DETECTORS

CE - CPR EN54-5 ATEX



Absorption temperature detector (for conventional control panels) TMP2-JO and TMP2-TO series, ATEX certified explosion-proof enclosure. Automatic reset. ATEX II 2G Ex d IIC T6 certification

TECHNICAL SPECIFICATIONS

Power supply voltage:	12 - 24 V DC	IP class:	IP66
Stand-by current draw:	30 µA	Dimensions:	160 x 8 x 75 mm
Current draw during alarm status:	11 mA @ 13.7 V / 12 mA @ 24 V	Weight:	410 g
Operating temperature:	-20° ... 135° C		



Non-resettable linear heat detectors (thermosensitive cables)

Minimum order quantity 100m
Larger quantities in multiples of 50m

Thanks to their performance, reliability, simplicity of use and reduced costs, non-resettable linear heat detectors are suitable for all types of installations where fire detection via temperature control is envisaged. Thermosensitive cables are classified according to the type of external coating and according to the tripping temperature. The cable comprises two steel conductors individually insulated by means of a thermosensitive polymer. The cable is twisted in such a way as to ensure a minimum mechanical pressure between the two conductors, when the nominal temperature is reached the insulation between the conductors gives way allowing the two conductors to come into contact thus signaling the alarm condition to the control panel.

EPC SERIES BIPOLAR CABLE

FLAME-RETARDANT VINYL-BASED COATING. GOOD RESISTANCE TO CHEMICALS



Designed for commercial and industrial interior applications. This coating is characterized by good resistance to many common chemicals and excellent flexibility at low temperatures.

- External diameter: ± 4 mm
- Resistance: $0.607 \Omega / m$
- Marking at 1mt intervals with cable characteristics and certification markings

TECHNICAL SPECIFICATIONS	EPC155	EPC190	EPC220	EPC280	EPC356
Alarm temperature:	68° C	88° C	105° C	138° C	180° C
Installation temperature:	-40 ÷ +46° C	-40 ÷ +66° C	-40 ÷ +79° C	-40 ÷ +93° C	-40 ÷ +105° C

XLT SERIES CABLE

FLAME-RETARDANT VINYL-BASED COATING WITH LOW TRIPPING TEMPERATURE

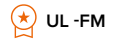

Designed for applications where a particularly low tripping temperature is contemplated, particularly suitable for applications in cold rooms. This coating is characterized by good resistance to many common chemicals and excellent flexibility at low temperatures.

- External diameter: ± 4 mm
- Resistance: $0.607 \Omega / m$
- Marking at 1mt intervals with cable characteristics and certification markings

TECHNICAL SPECIFICATIONS	XLT135
Alarm temperature:	57° C
Installation temperature:	-51 ÷ +38° C

XCR SERIES BIPOLAR CABLE

FOR PLACES WITH HAZARDOUS AMBIENT CONDITIONS, IT OFFERS EXCELLENT RESISTANCE TO MECHANICAL ABRASION, ACID, BASIC AND NEUTRAL CHEMICAL AGENTS AND LIQUID SOLVENTS

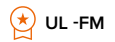

Coating made using a fluoropolymer which gives it excellent resistance to mechanical abrasion and chemical agents, making it particularly suitable both for outdoor applications and hostile ambients.

- External diameter: ± 4 mm
- Resistance: $0.607 \Omega / m$
- Marking at 1mt intervals with cable characteristics and certification markings

TECHNICAL SPECIFICATIONS	XCR155	XCR190	XCR220	XCR280	XCR356
Alarm temperature:	68° C	88° C	105° C	138° C	180° C
Installation temperature:	-40 ÷ +46° C	-40 ÷ +66° C	-40 ÷ +79° C	-40 ÷ +93° C	-40 ÷ +121° C

Accessories for linear heat detectors



TAR 362

THERMOSENSITIVE CABLE IDENTIFICATION PLATES

In plastic material, to be attached directly onto the cable. Background colour: red, wording colour: white. Written on the plate is the wording "ATTENTION FIRE DETECTION CABLE – WARNING FIRE DETECTION CABLE"



CL2

CABLE CLIPS FOR THERMOSENSITIVE CABLE

Cable clips for thermosensitive cable, in thermoplastic material, complete with stainless steel screw and bolt.



STFCL2

STAINLESS STEEL MOUNTING BRACKET FOR CL2

AISI304 steel bracket for CL2 base support. Dimensions: 200 x 50 sp. 2 mm.



PL-I

START OF LINE BOX IN ALUMINUM

- IP65 protection grade, dimensions 92 x 92 x 66 mm
- 4 terminals for connection of the detection line of the thermosensitive cable, type BK4
- The box is equipped with 1 PG7 cable gland, for the output of the thermosensitive cable
- The box is equipped with 1 PG13 cable gland, for entry of the signal cable



PL-F

END OF LINE BOX IN ALUMINIUM

- IP65 protection grade, dimensions 92 x 92 x 66 mm
- 4 terminals for connection of the detection line of the thermosensitive cable, type BK4
- The box is equipped with 1 PG7 cable gland, for the output of the thermosensitive cable



BRT-F-TW

END OF LINE BOX WITH TEST UNIT IN REINFORCED FIBERGLASS (GRP) TEST

- IP66 protection grade, black colour, dimensions 120 x 120 x 90 mm
- 4 terminals for connection of the detection lines of the thermosensitive cable
- Equipped with 1 PG 7 polyamide cable gland, for entry of the thermosensitive cable
- 1 key selector with 1 contact for the six-monthly test (SIMULATES ALARM)



PL-G

JUNCTION BOX IN ALUMINIUM

- IP65 protection grade, dimensions 92 x 92 x 66 mm
- 4 terminals for connection of the detection line of the thermosensitive cable, type BK4
- The box is equipped with 1 PG 7 cable gland, for entry of the thermosensitive cable
- The box is equipped with 1 PG 7 cable gland, for the output of the thermosensitive cable





Gas detection



See the
online
section

Products for monitoring technical environments and areas at risk of gas release

Fire detection very often goes hand in hand with GAS detection: detection of CO in car parks, detection of explosive gases in technical or battery charging rooms, detection of toxic gases or carbon dioxide in companies with specific processes, etc., are just a few examples.

The detectors proposed in this section, based on sensors of different technologies (Semiconductor, Catalytic, Electrochemical, infrared) and available in different enclosures (IP55, ATEX, ATEX with display and touchscreen) allow detection of a wide range of gases (depending on models): flammable, toxic or asphyxiant.

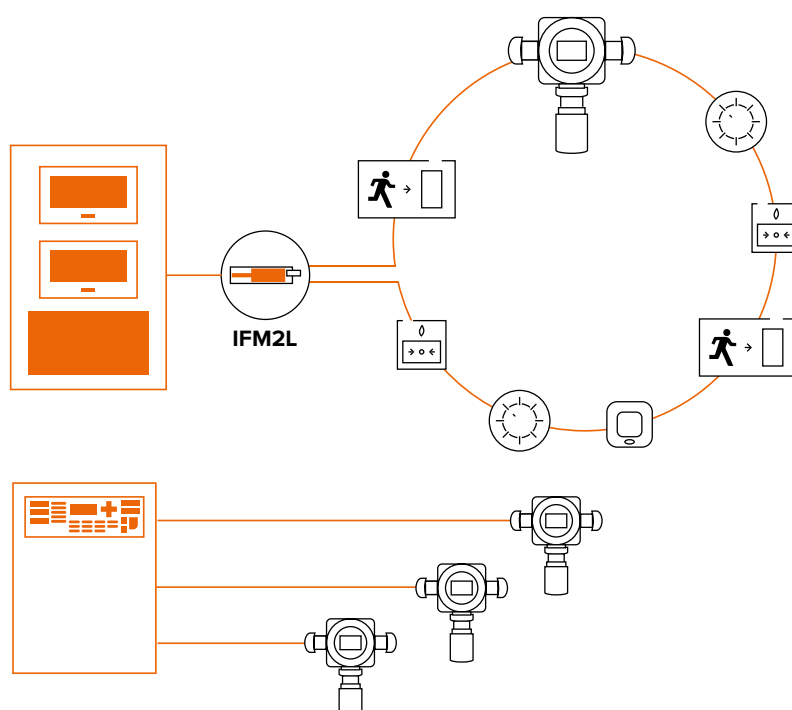



Industrial series gas detectors

The detectors from the Industrial series use the latest generation of microprocessor technology to deliver fast response and ensure accuracy and reliability. The sensitive element is connected to an interchangeable part, this solution allows the replacement of the head (the perishable part of the device) also by the installer, without the need for recalibration by the manufacturer. The complete product line includes a wide array of gas leak detectors, all available in explosion-proof or dust-proof

enclosures to satisfy even the most exacting requirements. During the installation phase or maintenance sessions it is possible to connect the detectors of the Industrial series to a PC or to an Android smartphone (using the INA55-701 adapter) to configure the parameters, modify the tripping thresholds, check the gas level reading or simulate alarm, pre-alarm and fault conditions.

Thresholds configurable in L.E.L. or P.P.M percentage (%) or percentage of the volume (for oxygen detector only) depending on the gas to be detected

- Selectable delays from 0 to 240 seconds for each individual threshold
- Reading compensation system in accordance with ambient temperature
- Replacement of sensor cap directly on-site without need of titrated gas canisters
- Connection to PC or Android SmartPhone (via INA55-700 interface) for threshold, filter and delay settings; real-time value readings, and simulation of alarm, pre-alarm and fault conditions



ING7
DETECTOR IN IP55 ENCLOSURE

Detector housed in an IP55 protection rated dust-proof metal enclosure. The sensitive element is located on the underside of the enclosure and is protected by a stainless steel mesh. The sensor cap can be easily and cost-efficiently replaced at the end of its functional life (3 years in favourable environments with no polluting agents) without any need of dismantling the detector.



INE7
DETECTOR IN EXPLOSION-PROOF ENCLOSURE

II 2G Ex d IIC T6 ATEX certified detector in explosion-proof enclosure; the electronic circuitry housing is made from diecast aluminium suitable for installation in classified areas. The sensitive element is located on the lower part of the aluminium enclosure and is housed inside a stainless steel AISI 303 cylinder with a resined, chrome-plated brass protection. The sensitive element is protected by a synthesized steel powder disc. The sensor cap can be easily and cost-efficiently replaced at the end of its functional life (3 years in favourable environments with no polluting agents) without any need of dismantling the detector.



INE7T
DETECTOR IN EXPLOSION-PROOF HOUSING WITH LCD TOUCH SCREEN

Detector in explosion-proof enclosure like the INE7 series detectors with the addition of a touchscreen LCD, thanks to which calibration, verification and maintenance operations can be performed without opening the enclosure. Thanks to this feature, it is possible to operate in environments classified as safe.

Orders for Detectors must specify not only the type of enclosure, but also the type of gas, the technology of the sensitive element and the type of output interface. Following is a schematic representation of the order codes.

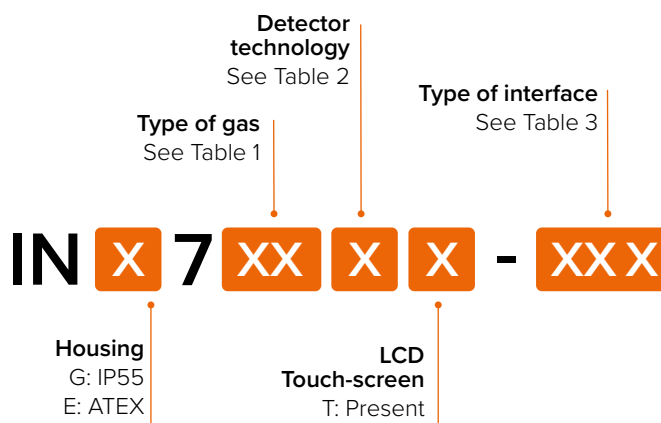

TABLE 1

Code	Gas detected	Pre-set Pre-alarm/Alarm thresholds	Range
00	Methane (CH ₄)	15/30 % L.E.L.	0 - 100% L.E.L.
01C/01P	Hazard gases (see Order Code Table)	15/30 % L.E.L.	0 - 100% L.E.L.
01D	Refrigerant gases	15/30 % L.E.L.	0 - 100% L.E.L.
01HNO ₂	Nitrogen dioxide (NO ₂)	5 / 10 ppm	0 - 20 ppm
01HH ₂ S	Hydrogen Sulphide (H ₂ S)	5 / 10 ppm	0 - 20 ppm
01IR	Carbon dioxide (CO ₂) / Butane (C ₄ H ₁₀)	1000 / 2000 ppm, 4000 / 8000 ppm 10000 / 20000 ppm	0 - 10000 ppm 0 - 30000 ppm
02	Petrol fumes	15/30 % L.E.L.	0 - 100% L.E.L.
03	Carbon monoxide (CO)	100 / 200 ppm	0 - 500 ppm
04	Hydrogen (H ₂)	15/30 % L.E.L.	0 - 100% L.E.L.
05	LPG (Liquid Petroleum Gas)	15/30 % L.E.L.	0 - 100% L.E.L.
06	Propane	15/30 % L.E.L.	0 - 100% L.E.L.
07	Ammonia (NH ₃)	100 / 200 ppm	0 - 500 ppm
08	Ammonia (NH ₃)	1000 / 2000 PPM	0 - 2000 ppm
09	Acetylene	15/30 % L.E.L.	0 - 100% L.E.L.
10	Oxygen (Excess)	24% / 27%	21 - 42% volume
11	Oxygen (Defect)	18% / 15%	21 - 0% volume

TABLE 2

Code	Technology of sensitive element of detector
S	Semiconductor
C	catalytic
P	Pellistor
H	Electrochemical cell
IR	infrared

TABLE 3

Code	Type of interface
RL	3 relays (Alarm, Pre-alarm and Fault)
AS-C	Connection with conventional line (provides Pre-alarm, Alarm and Fault signalling. One detector only per line)
AS-M	Connection for Inim supervised input modules
42	4-20 mA module
LE	Direct connection to Inim loop
MB	MODBUS

TECHNICAL SPECIFICATIONS

Power supply voltage:	11 – 30 V DC	
Standby current consumption	Semiconductor sensors	50 mA
	Catalytic sensors	70 mA
	Electrochemical sensors	30 mA
Alarm current consumption	Semiconductor sensors	80 mA
	Catalytic sensors	100 mA
	Electrochemical sensors	60 mA
Operating temperature:	0 ... + 40 °C	
Weight:	IP55 enclosure	370 g
	ATEX enclosure	1000g
Dimensions:	IP55 enclosure	141 x 100 x 60 mm
	ATEX enclosure	165 x 90 x 80 mm
Maximum ambient air speed in the protected ambient:	10 m/S	



DETECTOR WITH SEMICONDUCTOR SENSITIVE ELEMENT

SUITABLE FOR ENVIRONMENTS WITH CLEAN AND DRY AIR

In IP55 enclosure

	42	RL	AS-M	AS-C	LE	MB	Replacement sensor
	4-20 mA	Relay	For connection to Inim addressable modules	For connection to SmartLine conventional control panels	Direct connection to Inim loops	For MODBUS connection	
Methane	ING700S-42	ING700S-RL	ING700S-AS-M	ING700S-AS-C	ING700S-LE	ING700S-MB	INRG-700S
Refrigerant gases *	ING701D-42	ING701D-RL	ING701D-AS-M	ING701D-AS-C	ING701D-LE	ING701D-MB	INRG-701D
Ammonia (500 ppm)	ING707S-42	ING707S-RL	ING707S-AS-M	ING707S-AS-C	ING707S-LE	ING707S-MB	INRG-707S
Ammonia (2000 ppm)	ING708S-42	ING708S-RL	ING708S-AS-M	ING708S-AS-C	ING708S-LE	ING708S-MB	INRG-708S

In ATEX enclosure

	42	RL	AS-M	AS-C	LE	MB	Replacement sensor
	4-20 mA	Relay	For connection to Inim addressable modules	For connection to SmartLine conventional control panels	Direct connection to Inim loops	For MODBUS connection	
Methane	INE700S-42	INE700S-RL	INE700S-AS-M	INE700S-AS-C	INE700S-LE	INE700S-MB	INRE-700S
Refrigerant gases *	INE701D-42	INE701D-RL	INE701D-AS-M	INE701D-AS-C	INE701D-LE	INE701D-MB	INRE-701D
Ammonia (500 ppm)	INE707S-42	INE707S-RL	INE707S-AS-M	INE707S-AS-C	INE707S-LE	INE707S-MB	INRE-707S
Ammonia (2000 ppm)	INE708S-42	INE708S-RL	INE708S-AS-M	INE708S-AS-C	INE708S-LE	INE708S-MB	INRE-708S

* List of refrigerant gases: R32, R410a, R404a, R134a, R1234yf

DETECTOR WITH CATALYTIC SENSITIVE ELEMENT

SUITABLE FOR ENVIRONMENTS WITH LIGHT POLLUTION

In IP55 enclosure

	42	RL	AS-M	AS-C	LE	MB	Replacement sensor
	4-20 mA	Relay	For connection to Inim addressable modules	For connection to SmartLine conventional control panels	Direct connection to Inim Loops	For MODBUS connection	
Methane	ING700C-42	ING700C-RL	ING700C-AS-M	ING700C-AS-C	ING700C-LE	ING700C-MB	INRG-700C
Hazard gases**	ING701C-42	ING701C-RL	ING701C-AS-M	ING701C-AS-C	ING701C-LE	ING701C-MB	INRG-701C
Petrol fumes	ING702C-42	ING702C-RL	ING702C-AS-M	ING702C-AS-C	ING702C-LE	ING702C-MB	INRG-702C
Hydrogen	ING704C-42	ING704C-RL	ING704C-AS-M	ING704C-AS-C	ING704C-LE	ING704C-MB	INRG-704C
LPG	ING705C-42	ING705C-RL	ING705C-AS-M	ING705C-AS-C	ING705C-LE	ING705C-MB	INRG-705C
Propane	ING706C-42	ING706C-RL	ING706C-AS-M	ING706C-AS-C	ING706C-LE	ING706C-MB	INRG-706C
Acetylene	ING709C-42	ING709C-RL	ING709C-AS-M	ING709C-AS-C	ING709C-LE	ING709C-MB	INRG-709C

In ATEX enclosure

	42	RL	AS-M	AS-C	LE	MB	Replacement sensor
	4-20 mA	Relay	For connection to Inim addressable modules	For connection to SmartLine conventional control panels	Direct connection to Inim Loops	For MODBUS connection	
Methane	INE700C-42	INE700C-RL	INE700C-AS-M	INE700C-AS-C	INE700C-LE	INE700C-MB	INRE-700C
Hazard gases**	INE701C-42	INE701C-RL	INE701C-AS-M	INE701C-AS-C	INE701C-LE	INE701C-MB	INRE-701C
Petrol fumes	INE702C-42	INE702C-RL	INE702C-AS-M	INE702C-AS-C	INE702C-LE	INE702C-MB	INRE-702C
Hydrogen	INE704C-42	INE704C-RL	INE704C-AS-M	INE704C-AS-C	INE704C-LE	INE704C-MB	INRE-704C
LPG	INE705C-42	INE705C-RL	INE705C-AS-M	INE705C-AS-C	INE705C-LE	INE705C-MB	INRE-705C
Propane	INE706C-42	INE706C-RL	INE706C-AS-M	INE706C-AS-C	INE706C-LE	INE706C-MB	INRE-706C
Acetylene	INE709C-42	INE709C-RL	INE709C-AS-M	INE709C-AS-C	INE709C-LE	INE709C-MB	INRE-709C

** Hazard gases list (verify if available). Methanol (methyl alcohol), Pentane, Heptane, Ethyl acetate, Ethylene, Ethanol (Ethyl alcohol), Butane, Exane, iso-Butane.



DETECTOR WITH PELLISTOR SENSITIVE ELEMENT

SUITABLE FOR POLLUTED ENVIRONMENTS

In IP55 enclosure

	42	RL	AS-M	AS-C	LE	MB	Replacement sensor
	4-20 mA	Relay	For connection to Inim addressable modules	For connection to SmartLine conventional control panels	Direct connection to Inim Loops	For MODBUS connection	
Methane	ING700P-42	ING700P-RL	ING700P-AS-M	ING700P-AS-C	ING700P-LE	ING700P-MB	INRG-700P
Hazard gases*	ING701P-42	ING701P-RL	ING701P-AS-M	ING701P-AS-C	ING701P-LE	ING701P-MB	INRG-701P
Petrol fumes	ING702P-42	ING702P-RL	ING702P-AS-M	ING702P-AS-C	ING702P-LE	ING702P-MB	INRG-702P
Hydrogen	ING704P-42	ING704P-RL	ING704P-AS-M	ING704P-AS-C	ING704P-LE	ING704P-MB	INRG-704P
LPG	ING705P-42	ING705P-RL	ING705P-AS-M	ING705P-AS-C	ING705P-LE	ING705P-MB	INRG-705P
Propane	ING706P-42	ING706P-RL	ING706P-AS-M	ING706P-AS-C	ING706P-LE	ING706P-MB	INRG-706P
Acetylene	ING709P-42	ING709P-RL	ING709P-AS-M	ING709P-AS-C	ING709P-LE	ING709P-MB	INRG-709P

In ATEX enclosure

	42	RL	AS-M	AS-C	LE	MB	Replacement sensor
	4-20 mA	Relay	For connection to Inim addressable modules	For connection to SmartLine conventional control panel terminals	Direct connection to Inim Loops	For MODBUS connection	
Methane	INE700P-42**	INE700P-RL**	INE700P-AS-M	INE700P-AS-C	INE700P-LE	INE700P-MB	INRE-700P
Hazard gases*	INE701P-42	INE701P-RL	INE701P-AS-M	INE701P-AS-C	INE701P-LE	INE701P-MB	INRE-701P
Petrol fumes	INE702P-42	INE702P-RL	INE702P-AS-M	INE702P-AS-C	INE702P-LE	INE702P-MB	INRE-702P
Hydrogen	INE704P-42	INE704P-RL	INE704P-AS-M	INE704P-AS-C	INE704P-LE	INE704P-MB	INRE-704P
LPG	INE705P-42	INE705P-RL	INE705P-AS-M	INE705P-AS-C	INE705P-LE	INE705P-MB	INRE-705P
Propane	INE706P-42	INE706P-RL	INE706P-AS-M	INE706P-AS-C	INE706P-LE	INE706P-MB	INRE-706P

In ATEX enclosure with LCD touch screen display

	42	RL	AS-M	AS-C	LE	MB	Replacement sensor
	4-20 mA	Relay	For connection to Inim addressable modules	For connection to SmartLine conventional control panel terminals	Direct connection to Inim Loops	For MODBUS connection	
Methane	INE700PT-42**	INE700PT-RL**	INE700PT-AS-M	INE700PT-AS-C	INE700PT-LE	INE700PT-MB	INRE-700P
Hazard gases*	INE701PT-42	INE701PT-RL	INE701PT-AS-M	INE701PT-AS-C	INE701PT-LE	INE701PT-MB	INRE-701P
Petrol fumes	INE702PT-42	INE702PT-RL	INE702PT-AS-M	INE702PT-AS-C	INE702PT-LE	INE702PT-MB	INRE-702P
Hydrogen	INE704PT-42	INE704PT-RL	INE704PT-AS-M	INE704PT-AS-C	INE704PT-LE	INE704PT-MB	INRE-704P
LPG	INE705PT-42	INE705PT-RL	INE705PT-AS-M	INE705PT-AS-C	INE705PT-LE	INE705PT-MB	INRE-705P
Propane	INE706PT-42	INE706PT-RL	INE706PT-AS-M	INE706PT-AS-C	INE706PT-LE	INE706PT-MB	INRE-706P
Acetylene	INE709PT-42	INE709PT-RL	INE709PT-AS-M	INE709PT-AS-C	INE709PT-LE	INE709PT-MB	INRE-709P

* Hazard gases list (verify if available).

Methanol (methyl alcohol), Pentane, Heptane, Ethyl acetate, Ethylene, Ethanol (Ethyl alcohol), Butane, Exane, iso-Butane.

** EN60079-29-1 version available.



DETECTORS WITH ELECTROCHEMICAL CELL TYPE SENSITIVE ELEMENT

SUITABLE FOR TOXIC GAS DETECTION (MEASURING IN PPM)

In IP55 enclosure

	42	RL	AS-M	AS-C	LE	MB	Replacement sensor
	4-20 mA	Relay	For connection to Inim addressable modules	For connection to SmartLine conventional control panels	Direct connection to Inim Loops	For MODBUS connection	
Nitrogen dioxide	ING701HNO2-42	ING701HNO2-RL	ING701HNO2-AS-M	ING701HNO2-AS-C	ING701HNO2-LE	ING701HNO2-MB	INRG-701HNO2
Hydrogen Sulphide	ING701HH2S-42	ING701HH2S-RL	ING701HH2S-AS-M	ING701HH2S-AS-C	ING701HH2S-LE	ING701HH2S-MB	INRG-701HH2S
Carbon monoxide	ING703H-42	ING703H-RL	ING703H-AS-M	ING703H-AS-C	ING703H-LE	ING703H-MB	INRG-703H
Carbon monoxide EN50545	ING703HPK-42	ING703HPK-RL4	/	/	ING703HPK-LE	ING703HPK-MB	INRG-703HPK
Ammonia (500 ppm)	ING707H-42	ING707H-RL	ING707H-AS-M	ING707H-AS-C	ING707H-LE	ING707H-MB	INRG-707H
Ammonia (2000 ppm)	ING708H-42	ING708H-RL	ING708H-AS-M	ING708H-AS-C	ING708H-LE	ING708H-MB	INRG-708H
Oxygen (Excess)	ING710H-42	ING710H-RL	ING710H-AS-M	ING710H-AS-C	ING710H-LE	ING710H-MB	INRG-710H
Oxygen (Defect)	ING711H-42	ING711H-RL	ING711H-AS-M	ING711H-AS-C	ING711H-LE	ING711H-MB	INRG-711H
Oxygen for medical applications (excess)	ING710HMD-42	ING710HMD-RL	ING710HMD-AS-M	ING710HMD-AS-C	ING710HMD-LE	ING710HMD-MB	INRG-710HMD
Oxygen for medical applications (defect)	ING711HMD-42	ING711HMD-RL	ING711HMD-AS-M	ING711HMD-AS-C	ING711HMD-LE	ING711HMD-MB	INRG-711HMD

In ATEX enclosure

	42	RL	AS-M	AS-C	LE	MB	Replacement sensor
	4-20 mA	Relay	For connection to Inim addressable modules	For connection to SmartLine conventional control panels	Direct connection to Inim Loops	For MODBUS connection	
Nitrogen dioxide	INE701HNO2-42	INE701HNO2-RL	INE701HNO2-AS-M	INE701HNO2-AS-C	INE701HNO2-LE	INRE-701HNO2-MB	INRE-701HNO2
Hydrogen Sulphide	INE701HH2S-42	INE701HH2S-RL	INE701HH2S-AS-M	INE701HH2S-AS-C	INE701HH2S-LE	INRE-701HH2S-MB	INRE-701HH2S
Carbon monoxide	INE703H-42	INE703H-RL	INE703H-AS-M	INE703H-AS-C	INE703H-LE	INRE-703H-MB	INRE-703H
Ammonia (500 ppm)	INE707H-42	INE707H-RL	INE707H-AS-M	INE707H-AS-C	INE707H-LE	INRE-707H-MB	INRE-707H
Ammonia (2000 ppm)	INE708H-42	INE708H-RL	INE708H-AS-M	INE708H-AS-C	INE708H-LE	INRE-708H-MB	INRE-708H
Oxygen (Excess)	INE710H-42	INE710H-RL	INE710H-AS-M	INE710H-AS-C	INE710H-LE	INRE-710H-MB	INRE-710H
Oxygen (Defect)	INE711H-42	INE711H-RL	INE711H-AS-M	INE711H-AS-C	INE711H-LE	INRE-711H-MB	INRE-711H

In ATEX enclosure with LCD touch screen display

	42	RL	AS-M	AS-C	LE	MB	Replacement sensor
	4-20 mA	Relay	For connection to Inim addressable modules	For connection to SmartLine conventional control panel terminals	Direct connection to Inim Loops	For MODBUS connection	
Nitrogen dioxide	INE701HTNO2-42	INE701HTNO2-RL	INE701HTNO2-AS-M	INE701HTNO2-AS-C	INE701HTNO2-LE	INE701HTNO2-MB	INRE-701HNO2
Hydrogen Sulphide	INE701HTH2S-42	INE701HTH2S-RL	INE701HTH2S-AS-M	INE701HTH2S-AS-C	INE701HTH2S-LE	INE701HTH2S-MB	INRE-701HH2S
Carbon monoxide	INE703HT-42	INE703HT-RL	INE703HT-AS-M	INE703HT-AS-C	INE703HT-LE	INE703HT-MB	INRE-703H
Ammonia (500 ppm)	INE707HT-42	INE707HT-RL	INE707HT-AS-M	INE707HT-AS-C	INE707HT-LE	INE707HT-MB	INRE-707H
Ammonia (2000 ppm)	INE708HT-42	INE708HT-RL	INE708HT-AS-M	INE708HT-AS-C	INE708HT-LE	INE708HT-MB	INRE-708H
Oxygen (Excess)	INE710HT-42	INE710HT-RL	INE710HT-AS-M	INE710HT-AS-C	INE710HT-LE	INE710HT-MB	INRE-710H
Oxygen (Defect)	INE711HT-42	INE711HT-RL	INE711HT-AS-M	INE711HT-AS-C	INE711HT-LE	INE711HT-MB	INRE-711H



DETECTORS WITH INFRARED SENSITIVE ELEMENT

SUITABLE FOR SELECTIVE MEASURE OF SPECIFIC GASES

In IP55 enclosure

	42	RL	AS-M	AS-C	LE	MB	Replacement sensor
	4-20 mA	Relay	For connection to Inim addressable modules	For connection to SmartLine conventional control panels	Direct connection to Inim Loops	For MODBUS connection	
Methane	ING700IR-42	ING700IR-RL	ING700IR-AS-M	ING700IR-AS-C	ING700IR-LE	ING700IR-MB	INRG-700IR
Carbon Dioxide / Butane ***	ING701IR-42	ING701IR-RL	ING701IR-AS-M	ING701IR-AS-C	ING701IR-LE	ING701IR-MB	INRG-701IR
LPG	ING705IR-42	ING705IR-RL	ING705IR-AS-M	ING705IR-AS-C	ING705IR-LE	ING705IR-MB	INRG-705IR
Propane	ING706IR-42	ING706IR-RL	ING706IR-AS-M	ING706IR-AS-C	ING706IR-LE	ING706IR-MB	INRG-706IR

In ATEX enclosure

	42	RL	AS-M	AS-C	LE	MB	Replacement sensor
	4-20 mA	Relay	For connection to Inim addressable modules	For connection to SmartLine conventional control panels	Direct connection to Inim Loops	For MODBUS connection	
Methane	INE700IR-42	INE700IR-RL	INE700IR-AS-M	INE700IR-AS-C	INE700IR-LE	INE700IR-MB	INRE-700IR
Carbon Dioxide/Butane***	INE701IR-42	INE701IR-RL	INE701IR-AS-M	INE701IR-AS-C	INE701IR-LE	INE701IR-MB	INRE-701IR
LPG	INE705IR-42	INE705IR-RL	INE705IR-AS-M	INE705IR-AS-C	INE705IR-LE	INE705IR-MB	INRE-705IR
Propane	INE706IR-42	INE706IR-RL	INE706IR-AS-M	INE706IR-AS-C	INE706IR-LE	INE706IR-MB	INRE-706IR

Detectors with INFRARED sensitive element in ATEX enclosure with LCD touch-screen display

Suitable for selective measure of specific gases

	42	RL	AS-M	AS-C	LE	MB	Replacement sensor
	4-20 mA	Relay	For connection to Inim addressable modules	For connection to SmartLine conventional control panels	Direct connection to Inim Loops	For MODBUS connection	
Methane	INE700IRT-42	INE700IRT-RL	INE700IRT-AS-M	INE700IRT-AS-C	INE700IRT-LE	INE700IRT-MB	INRE-700IR
Carbon Dioxide / Butane ***	INE701IRT-42	INE701IRT-RL	INE701IRT-AS-M	INE701IRT-AS-C	INE701IRT-LE	INE701IRT-MB	INRE-701IR
LPG	INE705IRT-42	INE705IRT-RL	INE705IRT-AS-M	INE705IRT-AS-C	INE705IRT-LE	INE705IRT-MB	INRE-705IR
Propane	INE706IRT-42	INE706IRT-RL	INE706IRT-AS-M	INE706IRT-AS-C	INE706IRT-LE	INE706IRT-MB	INRE-706IR

*** To be specified in the order:

- Detectable gas type (Carbon Dioxide or Butane)
- Threshold for Carbon Dioxide (1000/2000 ppm, 4000/8000 ppm or 10000/20000 ppm)
- Measuring range for Carbon Dioxide (0 - 10000 ppm or 0 - 30000 ppm)

Accessories

INA55-701 - PC OR ANDROID SMARTPHONE INTERFACE FOR GAS DETECTORS

It allows interfacing the detector with a PC or smartphone with an Android operating system, as well as reading and modifying the detector parameters, simulating the pre-alarm, alarm and fault status. Complete with CD containing the required App.

INA55-104 - VALVE FOR 1L CYLINDERS

INA55-108 - CUP FOR TEST AEROSOL DELIVERY

INA55-109 - STAINLESS STEEL MOUNTING BRACKET FOR ATEX STANDARD DETECTORS (WITHOUT DISPLAY)

INA55-110 - FLOWMETER WITH VALVE FOR THE 1L CYLINDERS

INA55-111 - FLOWMETER WITH VALVE FOR THE 3L AND 5L CYLINDERS



Test Cylinders

INB12 - 1 LITRE TESTER CANISTER FOR GAS DETECTORS

Functionality tester for gas detectors, to be used by qualified persons only, sufficient for approximately 8 tests.

INB34 - 3 LITERS TESTER CANISTER FOR GAS DETECTORS

Functionality tester for gas detectors, to be used by qualified persons only, sufficient for approximately 24 tests.

INB12 - 5 LITERS TESTER CANISTER FOR GAS DETECTORS

Functionality tester for gas detectors, to be used by qualified persons only, sufficient for approximately 40 tests.

Gas	1l disposable cylinder	3l disposable cylinder	5l disposable cylinder
Propane 20% L.E.L., suitable for LPG detectors also	INB12-100	INB34-100	INB58-100
Propane 40% L.E.L., suitable for LPG detectors also	INB12-101	INB34-101	INB58-101
Methane 20% L.E.L.	INB12-102	INB34-102	INB58-102
Methane 40% L.E.L.	INB12-103	INB34-103	INB58-103
Hydrogen 20% L.E.L.	INB12-104	INB34-104	INB58-104
Hydrogen 40% L.E.L.	INB12-105	INB34-105	INB58-105
Acetylene 20% L.E.L.	INB12-106	INB34-106	INB58-106
Acetylene 40% L.E.L.	INB12-107	INB34-107	INB58-107
Carbon monoxide, 150 ppm	INB12-108	INB34-108	INB58-108
Carbon monoxide, 300 ppm	INB12-109	INB34-109	INB58-109
Oxygen 25% Volume	INB12-110	INB34-110	INB58-110
Isobutane 20% L.E.L., suitable for petrol fumes detectors also	INB12-111	INB34-111	INB58-111
Isobutane 50% L.E.L., suitable for petrol fumes detectors also	INB12-112	INB34-112	INB58-112
Oxygen 15% Volume	INB12-113	INB34-113	INB58-113
25 ppm Ammonia in air	/	INB34-114	INB58-114
100 ppm Ammonia in air	/	INB34-115	INB58-115
500 ppm Ammonia in air	/	INB34-116	INB58-116
1000 ppm Ammonia in air	/	INB34-117	INB58-117
Carbon dioxide, 500 ppm, rest in air	INB12-118	INB34-118	INB58-118
Carbon dioxide, 1000 ppm, rest in air	INB12-119	INB34-119	INB58-119
Carbon dioxide, 5000 ppm, rest in air	INB12-120	INB34-120	INB58-120
Carbon dioxide, 10000 ppm, rest in air	INB12-121	INB34-121	INB58-121
Carbon dioxide, 20000 ppm, rest in air	INB12-122	INB34-122	INB58-122
Carbon dioxide, 30000 ppm, rest in air	INB12-123	INB34-123	INB58-123
Pentane 20% L.E.L.	INB12-124	INB34-124	INB58-124
Pentane 40% L.E.L.	INB12-125	INB34-125	INB58-125
Refrigerant gas	INB12-126	INB34-126	INB58-126
Benzene 20% L.E.L.	INB12-127	INB34-127	INB58-127
Benzene 36.92% L.E.L.	INB12-128	INB34-128	INB58-128
Nitrogen dioxide 5 ppm in air	/	INB34-129	INB58-129
Nitrogen dioxide 20 ppm in air	/	INB34-130	INB58-130

Elite series gas detectors

The detectors from the ELITE series represent excellence in the field of gas detection, the multiple technologies available (catalytic, pellistor, electrochemical or infrared sensitive elements), the wide range of detectable gases, the ease-of-use and trouble-free maintenance combined with the quality and reliability that distinguish

these devices makes the ELITE series a unique product range of its kind. Two buttons on-board each detector (F1 and F2) allow you to carry out tool-free calibration and maintenance operations. Trouble-free maintenance allows you to directly replace the cartridge with the sensitive element without need of calibration. The detectors are available in either IP55 or explosion-proof enclosures for use in potentially explosive areas (II 2 G Ex d IIC T6 Gb).





Gas detected	Sensitive element technology	3 relay Output + fault and 4-20mA		4-20mA module		Measuring range	Replacement cartridge		Calibration canister	Years*
		IP55	ATEX	IP55	ATEX		IP55	ATEX		
Methane	Catalytic	SE237KM	SE138KM	TS282KM	TS293KM	0 - 20% LEL	ZSK02	ZSK02/EX	BO200	5
	Pellistor	SE237PM	SE138PM	TS282PM	TS293PM	0 - 100% LEL	ZSP05	ZSP05/EX	BO200	5
	Infrared				TS293IM	0 - 100% LEL			BO200	
LPG	Catalytic	SE237KG	SE138KG	TS282KG	TS293KG	0 - 20% LEL	ZSK02	ZSK02/EX	BO200	5
	Pellistor	SE237PG	SE138PG	TS282PG	TS293PG	0 - 100% LEL	ZSP05	ZSP05/EX	BO200	5
	Infrared				TS293IG	0 - 100% LEL			BO200	
Hydrogen	Catalytic	SE237KI	SE138KI	TS282KI	TS293KI	0 - 20% LEL	ZSK02	ZSK02/EX	BO200	5
	Pellistor	SE237PI	SE138PI	TS282PI	TS293PI	0 - 100% LEL	ZSP05	ZSP05/EX	BO200	5
Petrol	Catalytic	SE237KB	SE138KB	TS282KB	TS293KB	0 - 20% LEL	ZSK04	ZSK04/EX	BO200	5
	Pellistor	SE237PB	SE138PB	TS282PB	TS293PB	0 - 100% LEL	ZSP05	ZSP05/EX	BO200	5
Ammonia	Electrochemical	SE237EA	SE138EA	TS282EA	TS293EA	0 - 300 ppm	ZSEA1	ZSEA1/EX	BO501	3
	Electrochemical	SE237EA-H	SE138EA-H	TS282EA-H	TS293EA-H	0 - 300 ppm			BO501	
Carbon monoxide	Electrochemical	SE237EC-S	SE138EC-S	TS282EC-S	TS293EC-S	0 - 300 ppm	ZSEC1	ZSEC1/EX	BO210	3
	Electrochemical	SE237EC-H	SE138EC-H	TS282EC-H	TS293EC-H	0 - 300 ppm		ZSEC2/EX	BO210	2
Hydrogen Sulphide	Electrochemical	SE237EH	SE138EH	TS282EH	TS293EH	0 - 100 ppm	ZSEH1	ZSEH1/EX	BO470	2
Nitrogen Oxide	Electrochemical	SE237EN	SE138EN	TS282EN	TS293EN	0 - 300 ppm	ZSEN1	ZSEN1/EX	BO472	2
Nitrogen dioxide	Electrochemical	SE237EN2	SE138EN2	TS282EN2	TS293EN2	0 - 30 ppm	ZSEN2	ZSEN2/EX	BO018	2
Oxygen**	Electrochemical	SE237EO	SE138EO			0 - 25 % Volume	ZSEO1	ZSEO1/EX	BO015	2
Sulfur Dioxide	Electrochemical	SE237ES	SE138ES	TS282ES	TS293ES	0 - 20 ppm	ZSES1	ZSES1/EX	BO418	2
Acetylene	Pellistor		SE138PE		TS293PE	0 - 100% LEL		ZSP02/EX	BO200	5
Styrene	Pellistor		SE138PS		TS293PS	0 - 100% LEL		ZSP03/EX	BO200	5
Hydrocyanic Acid	Electrochemical	SE237EHCN	SE138EHCN	TS282EHCN		0 - 10 ppm	ZSEHCN		BO479	2
Hydrochloric Acid	Electrochemical	SE237EHCL	SE138EHCL	TS282EHCL	TS293EHCL	0 - 30 ppm	ZSEHCL	ZSEHCL/EX	WR000	2
Hazard gases (by request)	Catalytic***	SE237KX	SE138KX			0 - 20% LEL			BO200	5
	Pellistor***	SE237PX	SE138PX	TS282PX	TS293PX	0 - 100% LEL	ZSP05	ZSP05/EX	BO200	5
	Pellistor****		SE138PX-H		TS293PX-H	0 - 100% LEL			BO200	5
	Infrared****				TS293IX	0 - 100% LEL				
Carbon dioxide	Infrared			TS282IC2	TS293IC2	0 - 5% Vol.				
				TS282IC2-H	TS293IC2-H	0 - 5000 ppm				
CO + Petrol Fumes (for parking areas)	Catalytic			TS255CB			ZSEC1 - ZSK04		BO200 / BO210	
CO + Nitrogen Dioxide	Electrochemical			TS255CN2			ZSEC1 - ZSEN2		BO008 / BO018	

*Average life in clean air (years).

** Cannot be connected as 4-20 mA to the I/O terminals of the SmartLine or the loop modules.

*** Ethyl acetate, Acetone, Isopropolic alcohol, Ammonia, Heptane, Hexane, Ethanol (Ethyl alcohol).

**** Acetone, Tertiary Butyl alcohol, Butyl alcohol-n, Isobutyl alcohol, Isopropolic alcohol (2-Propanol), Propylic alcohol (1-Propanol), Ammonia, Petrol (green), Butane, Butene-2-trans, Butene-1, Butene-2cis (Butene-2), Cyclohexane, Decan, Heptane, Hexane, Ethane, Ethanol (Ethyl alcohol), Ethylene, Hydrogen, Iso-butane, Iso-pentane, Methane, Methyl ethyl ketone (Butanone), Nitromethane, Nonane, Carbon monoxide, Octane-n.



Detectors from the gas Value Line series

The detectors from the Gas Value Line series are characterized by an extremely reasonable price, housed in an IP44 or IP65 plastic enclosure, depending on the model or in an ATEX certified metal enclosure, 4-20 mA interface, they represent an excellent solution in gas alarm systems in car parks, thermal power plants, and environments to be protected from possible gas leaks such as methane, LPG, etc.

SE192

VALUE LINE SERIES GAS DETECTOR



They are equipped with a 4-20 mA interface with full scale equal to 20% L.E.L. for explosive gas detectors and 300ppm for the CO detectors. The IP44 protection grade plastic enclosure is aesthetically pleasing and well-finished. The detector allows practical testing, calibration and electrical test operations using the two buttons on the circuit, the titrated gas from the test cylinders can be applied to the sensitive element using the TC011 or TC014 adapters. It is NOT possible to replace the sensing element once it has reached the end of its operational life cycle.

TECHNICAL SPECIFICATIONS	SE192KM	SE192KG	SE192KB	SE192KI	SE192EC
Gas	Methane	LPG	PETROL	HYDROGEN	CO
Bottom of scale	20% LEL	20% LEL	20% LEL	20% LEL	300 PPM
Test cylinder	BO200	BO200	BO200	BO200	BO210

SE182

VALUE LINE SERIES GAS DETECTOR



They are equipped with a 4-20 mA interface with full scale equal to 20% L.E.L. (K Version) or full scale equal to 100% L.E.L. (P version) for explosive gas detectors and 300ppm for the CO detector. The plastic enclosure guarantees IP65 protection grade. The detector allows practical testing, calibration and electrical test operations using the two buttons on the circuit, the titrated gas from the test cylinders can be applied to the sensitive element using the TC011 or TC014 adapters. It is NOT possible to replace the sensing element once it has reached the end of its operational life cycle.

TECHNICAL SPECIFICATIONS	SE182KM	SE182KG	SE182KB	SE182KI	SE182PM	SE182PG	SE182PB	SE182PI	SE182EC
Gas	Methane	LPG	Petrol	Hydrogen	Methane	LPG	Petrol	Hydrogen	CO
Range	20% LEL	20% LEL	20% LEL	20% LEL	100% LEL	100% LEL	100% LEL	100% LEL	300 PPM
Test cylinder	BO200	BO200	BO200	BO200	BO200	BO200	BO200	BO200	BO210

SE183

VALUE LINE SERIES GAS DETECTOR SERIES IN CERTIFIED EXPLOSION PROOF ENCLOSURE



Equipped with a 4-20 mA interface with full scale equal to 20% L.E.L. (K Version) or full scale equal to 100% L.E.L. (P version) for explosive gas detectors and 300ppm for the CO detector. The detector allows practical testing, calibration and electrical test operations using the two buttons on the circuit, the titrated gas from the test cylinders can be applied to the sensitive element using the TC011 or TC014 adapters. It is NOT possible to replace the sensing element once it has reached the end of its operational life cycle.
ATEX Ex II 2G Ex db IIC T5 Gb certified

TECHNICAL SPECIFICATIONS	SE183KM	SE183KG	SE183KB	SE183KI	SE183PM	SE183PG	SE183PB	SE183PI	SE183EC
Gas	Methane	LPG	Petrol	Hydrogen	Methane	LPG	Petrol	Hydrogen	CO
Range	20% LEL	20% LEL	20% LEL	20% LEL	100% LEL	100% LEL	100% LEL	100% LEL	300 PPM
Test cylinder	BO200	BO200	BO200	BO200	BO200	BO200	BO200	BO200	BO210

Accessories for Elite and Value Line series gas detectors



TC011

Calibration kit for Elite and Value Line gas detectors comprising calibration cap and flow meter.

TC014

Calibration kit for Elite and Value Line gas detectors comprising calibration cap and flow meter in stainless steel for highly reactive gases.

BO303

S-Flow valve for 34 – 58 – 110ltr canisters. Inert gases, Hydrogen Sulphide, Sulfur Dioxide, Ammonia. With flow meter and manometer.

BO305

HPC valve in stainless steel for 34 – 58 – 110ltr canisters. Reactive and highly reactive gases. With manometer.

BO311

MiniFlow valve for 12ltr canisters. Inert gases, Hydrogen Sulphide, Sulfur Dioxide, Ammonia. With flow meter and manometer.



TR530

Aluminium bracket for wall or ceiling mount of SE and TS series detectors.



AR015

Stainless steel cover for TR530 bracket for SE and TS series detectors.



TR533

Mechanical protection against accident impacts.





ATEX devices



See the
online
section

Certified products for applications with explosive atmosphere risk

Equipment suitable for environments where an explosive mixture of air and gas or vapour can be present continuously, intermittently or as a result of an accident, defined as hazardous areas by directive 2014/34/EU.

Electrical equipment for use in such areas must be designed so that it does not constitute an explosion ignition source, not only under normal operating conditions but also under fault conditions.

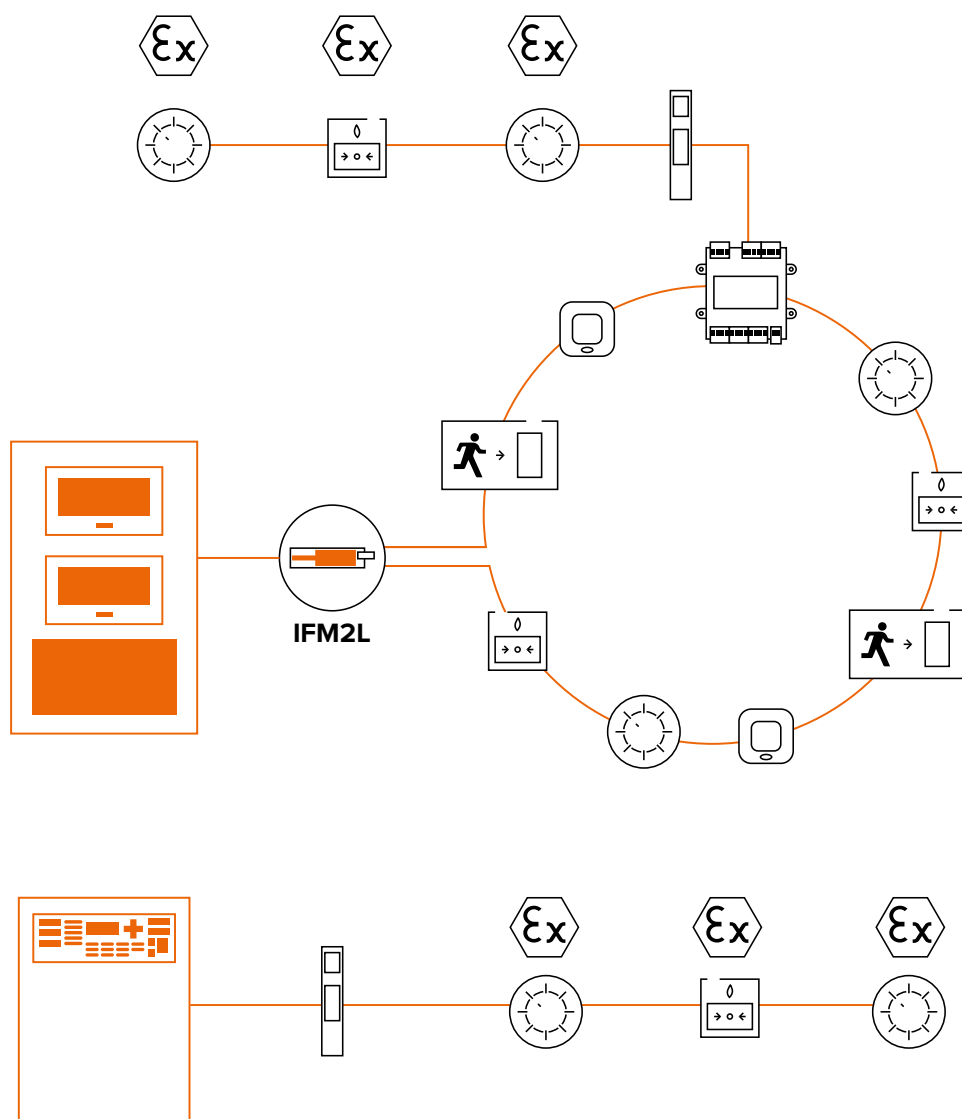



The ATEX marking

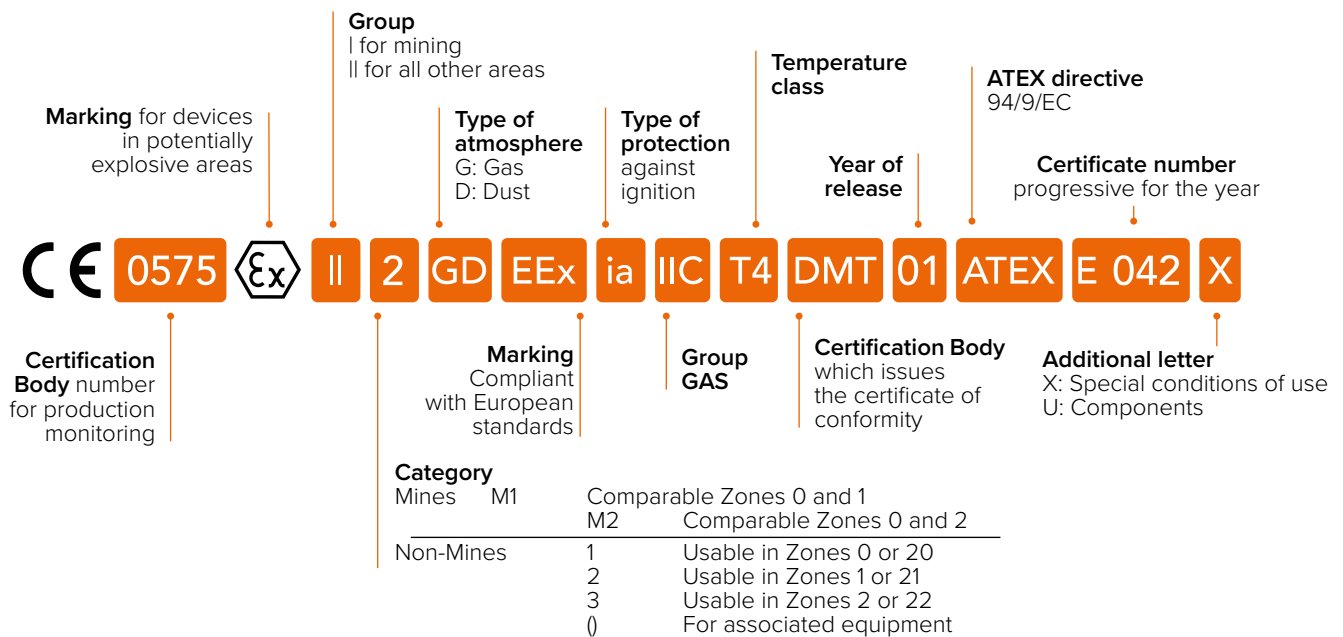

Orbis conventional detectors

ORB-HT-51145-APO

I.S. CONVENTIONAL DETECTORS, CATEGORY II 1G EX IA IIC T5



The conventional equipment of the Apollo Orbis I.S. proposed herein reaches the ATEX safety level by means of the "Intrinsically safe" technique. Intrinsically safe equipment operates at such low power and with such small amounts of stored energy that it does not constitute an ignition source under any operating conditions:

- In normal conditions
- With one fault only (for ib classification)
- With any combination of two faults (for ia classification)

HEAT DETECTOR

- ORB-HT-51145-APO** Class A1R Orbis I.S. 1G Ex ia IIC
T4 Ga (-50°C ≤ Ta ≤ +60°C) / T5 (-50°C ≤ Ta ≤ +40°C)
- ORB-HT-51157-APO** Class A1S Orbis I.S. 1G Ex ia IIC
T4 Ga (-50°C ≤ Ta ≤ +60°C) / T5 (-50°C ≤ Ta ≤ +40°C)
- ORB-HT-51147-APO** Class A2S Orbis I.S. 1G Ex ia IIC
T4 Ga (-50°C ≤ Ta ≤ +60°C) / T5 (-50°C ≤ Ta ≤ +40°C)
- ORB-HT-51149-APO** Class BR Orbis I.S. 1G Ex ia IIC
T4 Ga (-50°C ≤ Ta ≤ +60°C) / T5 (-50°C ≤ Ta ≤ +40°C)
- ORB-HT-51151-APO** Class BS Orbis I.S. 1G Ex ia IIC
T4 Ga (-50°C ≤ Ta ≤ +60°C) / T5 (-50°C ≤ Ta ≤ +40°C)
- ORB-HT-51153-APO** Class CR Orbis I.S. 1G Ex ia IIC
T4 Ga (-50°C ≤ Ta ≤ +60°C) / T5 (-50°C ≤ Ta ≤ +40°C)
- ORB-HT-51155-APO** Class CS Orbis I.S. 1G Ex ia IIC
T4 Ga (-50°C ≤ Ta ≤ +60°C) / T5 (-50°C ≤ Ta ≤ +40°C)

SMOKE AND HEAT DETECTOR

- ORB-OH-53027-APO** 1G Ex ia IIC T4 Ga (-50°C ≤ Ta ≤ +60°C) / T5 (-50°C ≤ Ta ≤ +40°C)

SMOKE DETECTOR

- ORB-OP-52027-APO** 1G Ex ia IIC T4 Ga (-50°C ≤ Ta ≤ +60°C) / T5 (-50°C ≤ Ta ≤ +40°C)

- ORB-MB-50018-APO** Mounting base for Orbis I.S. detectors



55100-031APO

ATEX CALL POINT IN I.S. TECHNOLOGIES OR EXPLOSION-PROOF



Buttons for manual activation of fire alarms for installation in ATEX classified areas

55100-031APO
55100-033APO
29600-508

I.S. conventional
I.S. conventional for outdoor use
Conventional in explosion-proof enclosure
(II 2 G Ex and d IIC T6 Gb Ta = -40°C to +55°C ; II 2 D Ex t IIIc T60°C Db)

TCC-0001 - IS

INTRINSECALLY SAFE CONVENTIONAL AUDIBLE AND VISUAL INDICATORS



The following Intrinsically Safe alarm devices are certified for use in ATEX classified environments for group I (mine) and group II (surface).

These signallers are to be used in combination with a certified Zener or Galvanic barrier. The characteristics of the barrier must not exceed Uo: 28V, Io: 93 mA, Po: 660 mW, Ci: 0, Li 0. The minimum Uo value should not fall below 23.6V and the minimum Io value should not fall below 50mA.

- Approved by ATEX, IECEx
- Group I MI Ex ia I Ma
- Group II IGD Ex ia IIC T6 Ga, Ex ia IIIc T85°C Da
- Zones 0, 1, 2, 20, 21 & 22;
- EN 60079-0:2012 + All:2013 (IEC 60079-0:2011) EN-60079-11:2012 + (IEC 60079-11:2011).
- Dustproof & Weatherproof

TCC-0001 - IS Sonos Sounder - Red with deep base
TCC-0007 - IS Sonos Sounder Beacon Red deep base Amber lens
TCC-0008 - IS Sonos Sounder Beacon Red deep base Red lens

TECHNICAL SPECIFICATIONS

Current draw:	33 mA	Protection grade:	IP66
Sound output:	105 dB @ 1 m	No. of Tones:	32 (internal DIP Switch)
Wire entry:	3x M20		
Operating temperature:	-40°C ... +55°C		

TCA-0004

ATEX EXPLOSION PROOF ALARM BELL



The Explosion Proof bell is designed for use in areas classified as Zone 1 and 2. IP66 protection grade, ATEX II 2G Exd and IIC T6 certified.

With up to 105dB audio output, it provides a clear signal is distinguishable over background noise.

- Approved by ATEX and CQST
- IMETRO and IECEx
- ATEX: II 2G Exd and IIC T6
- Zones 2
- Weatherproof

TECHNICAL SPECIFICATIONS

Current draw:	320 mA	Protection grade:	IP66
Sound output:	105 dB @ 1 m		
Nominal voltage:	24 V DC		
Operating temperature:	-40°C ... +40°C		



TCB-0017

ATEX EXPLOSION PROOF ALARM SIGNALLERS



The EXPLOSION PROOF alarm signallers listed below are certified for use in ATEX classified environments.

- TCB-0017** ATEX explosion proof alarm signaller
- TCB-0033** ATEX explosion proof visual/audible alarm signaller
5W Red LED flasher
- TCB-021** ATEX explosion proof visual/audible alarm signaller
Xenon 5j Red flasher
- TCB-025** ATEX explosion proof visual/audible alarm signaller
Xenon 10j Red flasher

- Approved by ATEX and CQST
- IMETRO and IECEX
- ATEX: II 2G Exd IIC T4 - T6 (incorporating IIA & IIB)
- Zones 1&2, Zones 21&22 (Pending)
- Conforms to EN (IEC) 60079-0 EN (IEC) 60079-1 and EN54
- Volume control
- Dustproof & Weatherproof

TECHNICAL SPECIFICATIONS

Current draw:	33 mA	Protection grade:	IP66
Sound output:	115 dB @ 1 m	No. of Tones:	63 (internal DIP Switch)
Wire entry:	4x M20, M25		
Operating temperature:	-40° ... +70° C		

IIIA ATEX

ATEX LINEAR SMOKE DETECTOR



Linear detector based on infrared modulation. It is constructed in an ATEX enclosure usable in Z1-2-21-22 classified areas and is composed of the following components:

- Transmitter Unit (Tx) and Receiver Unit (Rx) complete with aluminium pointing mechanism "Avional"
- Adjustment key
- Pair of EXD cable glands
- Pair of die-cast aluminium brackets
- Controller (CSRLS-ATEX)

TECHNICAL SPECIFICATIONS

Current draw:	320 mA	Protection grade:	IP66
Nominal voltage:	24 V DC	Operating distance:	from 10 a 120 m
Operating temperature:	-30° ... +65° C	Sound output:	105 dB @ 1 m
Installation class:	II C - 25° + 85° / 110° C - Z1-2-21-22		

29600-378

GALVANIC BARRIERS FOR ATEX DEVICES



29600-378 (P+F KFD0-CS-EX1.51P)

Galvanic barrier for conventional detectors – DIN rail mount

29600-440 (P+F KFD0-SD2-Ex1.1045)

Galvanic barrier for I.S. signallers - Max. 45 mA Allows supervision of the connection ONLY up to the entrance of the barrier, not in the ATEX zone

Addressable detectors and Apollo XP95 accessory items ATEX Certified

The devices of the XP95 I.S. series (Intrinsically Safe) are designed and certified for use in areas with inflammable atmospheres. These products are certified BASEEFA (British Approval Service for Electrical Equipment in Flammable Atmospheres) in compliance with EN50014 and EN50020 and approved E Ex ia IIC T5 (T4 to Ta < 60°C). The diagram illustrates the wiring method required for I.S. addressable detectors and the accessories to utilize.

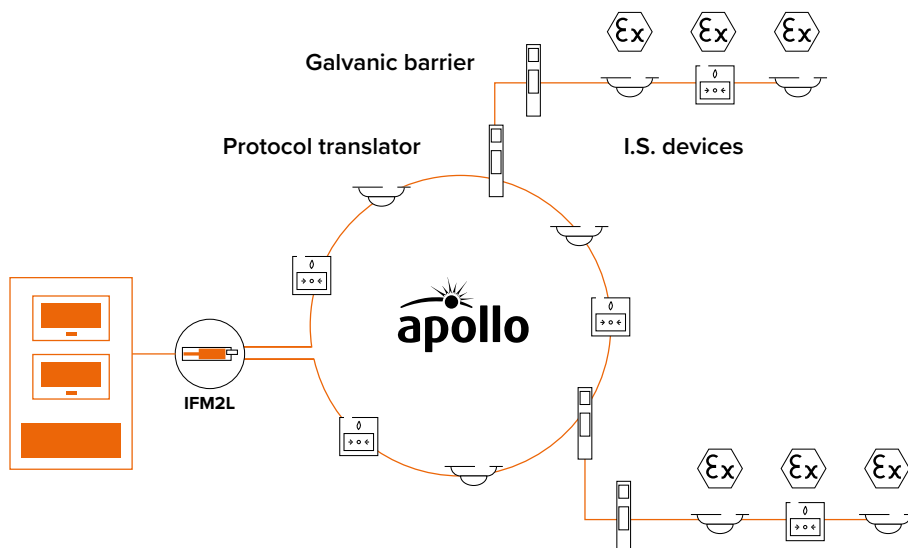

55000-440APO

XP95 I.S. ADDRESSABLE DETECTORS



I.S. addressable detectors, category II 1G Ex ia IIC T5



55000-440APO

I.S. addressable heat detector (A2S)
Approved E Ex ia IIC T5 (T4 a Ta < 60° C).

55000-640APO

I.S. addressable optical smoke detector
Approved E Ex ia IIC T5 (T4 a Ta < 60° C).

45681-215APO

I.S. mounting base for addressable detectors

55200-940

I.S. addressable call point

Approved E Ex ia IIC T5 (T4 a Ta < 60° C).

29600-196

FIXING BASES FOR DETECTORS



Allows the detector base to be fitted in such a way that the rear of the detector is sealed. Gives extra protection to devices fitted in areas where there is risk of moisture ingressing through the rear.



29600-196

Plastic deckhead mounting box with access ports threaded to fit PG16 glands.

29600-098

GALVANIC BARRIERS FOR ATEX DEVICES



29600-098 (P+F KFD0-CS-EX1.54)

Galvanic barrier for analogue detectors – DIN rail mount.

55000-855

Single channel protocol translator – DIN rail mount. For XP95 I.S. addressable devices.

55000-856

Dual channel protocol translator - DIN rail mount. For XP95 I.S. analogue-addressable devices.



Marine devices

This section contains a selection of detectors and accessories, both analogue addressable using Apollo protocol as well as conventional, certified for MARINE applications. The detectors shown here operate like the corresponding part number standard (see APOLLO Devices section) and share the same certifications, moreover they have been subjected to a series of specific additional tests for installations in the naval sector.

58000-400MAR

DISCOVERY SERIES ADDRESSABLE DEVICES, MARINE CERTIFIED



58000-400MAR

Heat detector

58000-700MAR

Combined smoke and heat detector

58000-600MAR

Smoke detector

45681-210MAR

Mounting base for detectors

45681-286MAR

Base with isolator for detectors

45681-394MAR

Sounder base with flasher (VID) and isolator for detectors

58100-970MAR

DISCOVERY SERIES ADDRESSABLE CALL POINTS, MARINE CERTIFIED



58100-970MAR

Discovery call point, Marine certified

58100-971MAR

Discovery call point with isolator, Marine certified

58200-975MAR

Discovery call point for outdoor use, Marine certified

58200-976MAR

Discovery call point with isolator for outdoor use, Marine certified

58100-976MAR

Discovery call point with isolator for outdoor use, Marine SIL2 certified

55000-773MAR

LOOP MODULES, MARINE CERTIFIED



55000-773MAR

Conventional zone module for DIN rail mounting, Marine certified

55000-181MAR

DIN rail mount output module for alarm signallers, Marine certified

55000-774MAR

DIN rail mount Input/output module, Marine certified

55000-770MAR

DIN rail mount dual channel short-circuit isolator, Marine certified

55000-775MAR

Mini input module, Marine certified

55000-772MAR

DIN rail mount Input module, Marine certified

ORB-HT-41001-MAR

ORBIS SERIES CONVENTIONAL DEVICES, MARINE CERTIFIED



ORB-HT-41001-MAR
ORB-HT-41013-MAR
ORB-HT-41002-MAR
ORB-HT-41014-MAR
ORB-HT-41003-MAR
ORB-HT-41015-MAR
ORB-HT-41004-MAR
ORB-HT-41016-MAR
ORB-HT-41005-MAR
ORB-HT-41017-MAR
ORB-HT-41006-MAR
ORB-HT-41018-MAR
ORB-OH-43001-MAR
ORB-OH-43003-MAR
ORB-OP-42001-MAR
ORB-OP-42003-MAR
ORB-MB-00001-MAR

A1R heat detector
 A1R heat detector with LED flasher
 A2S heat detector
 A2S heat detector with LED flasher
 BR heat detector
 BR heat detector with LED flasher
 BS heat detector
 BS heat detector with LED flasher
 CR heat detector
 CR heat detector with LED flasher
 CS heat detector
 CS heat detector with LED flasher
 Smoke and Heat detector
 Smoke and heat detector with LED flasher
 Smoke detector
 Smoke detector with LED flasher
 Mounting base for Orbis conventional detectors

55100-021MAR

CONVENTIONAL CALL POINTS, MARINE CERTIFIED



55100-021MAR
55100-022MAR

Conventional call point, Marine certified
 Conventional call point for outdoor use, Marine certified



Accessories for completion and system test

The following section describes a selection of accessories for the completion and system test, such as power supplies, electromagnetic stops for fire doors, etc., and a series of tools for carrying out commissioning or periodic tests of fire detection and alarm systems.





Accessory devices for fire extinguishment systems

IC0020

CALL POINTS IN VARIOUS COLOURS



The call points, both from the conventional and addressable series, can be supplied in different colours for applications other than fire alarm.

IC0020Y	Conventional call point in yellow
IC0020G	Conventional call point in green
IC0020B	Conventional call point in blue
IC0020W	Conventional call point in white
EC0020Y	Addressable call point in yellow
EC0020G	Addressable call point in green
EC0020B	Addressable call point in blue
EC0020W	Addressable call point in white

IC0011E

CONVENTIONAL CALL POINTS IN VARIOUS COLOURS FOR OUTDOOR USE



Conventional outdoor call-points come in different colours for applications other than fire alarm installations.

IC0011EY	Conventional call point in yellow
IC0011EG	Conventional call point in green
IC0011EB	Conventional call point in blue
IC0011EW	Conventional call point in white

ICB010

CALL POINTS WITHOUT RETENTION MECHANISM IN VARIOUS COLOURS



The following call points are without retention mechanism, when pressure on the button ceases the contact resets.

ICB010Y	Call point in yellow
ICB010G	Call point in green
ICB010B	Call point in blue
ICB010W	Call point in white

ICK010

KEY SWITCHES IN VARIOUS COLOURS



The following key switches are electrical contacts that can be activated and reset with a key. Useful for selecting different system operating modes.

ICK010Y	Key switch in yellow
ICK010G	Key switch in green
ICK010B	Key switch in blue
ICK010W	Key switch in white



ISS021 - ISS022

ADDRESSABLE AUDIBLE-VISUAL WARNING SIGN



Red alarm plate complete with EN54-3 certified audible signal. The ISS021 version is classified as a VID (Visual Indication Device) and is NOT certified for the visual part according to the EN54-23 standard. The ISS022 version is classified as a VAD (Visual Alarm Device) and includes an EN54-23 certified high power visual signaller. Comes with 'Fire alarm' written on it, available with different indications on request.



- ISS021 - ITA** VISUAL/AUDIBLE WARNING SIGN - "ALLARME INCENDIO"
- ISS022- ITA** VISUAL/AUDIBLE WARNING SIGN WITH FLASHER - "ALLARME INCENDIO"
- ISS021 - ENG** VISUAL/AUDIBLE WARNING SIGN WITH "FIRE ALARM" INDICATION
- ISS022- ENG** VISUAL/AUDIBLE WARNING SIGN WITH FLASHER - "FIRE ALARM"

PICTOGRAMS (box with 10 pieces)

- FOP45** "FIRE ALARM"
- FOP46** "DOOR ALARM"
- FOP47** "SPEGNIMENTO IN CORSO"
- FOP48** "EVACUARE IL LOCALE"
- FOP49** "ALLARME GAS"
- FOP36** "FIRE DO NOT ENTER"
- FOP37** "EXTINCIÓN DISPARADA"
- FOP38** "GAS DISCHARGE"
- FOP39** "FUEGO"
- FOP34** "PRESENZA ACETILENE"
- FOP35** "CARENZA OSSIGENO"

TECHNICAL SPECIFICATIONS	ISS022	ISS021
Sound output @ 1 m:		92 dB (A)
Light output:	EN54-23 W 4,6 - 9,1	/
Flash frequency:	1 Hz	/
Operating voltage:	11 - 30 V DC	18 - 30 V DC
Current draw:	50 mA	21 mA (media)
Dimensions (w x h x d):	293 x 130 x 75 mm	
Operating temperature:	-10° ... +55° C	



Power supply stations

The power supply stations of the SmartLevel family are certified according to the EN54 standard, they meet all the supervision, redundancy and heavy duty requirements imposed.

They are equipped internally with the new switching module with resonant technology and internal CPU for reliable, efficient and secure power management.

The power stations have an independent battery-charging circuit capable of charging the batteries without affecting the output current to the load, and a thermal probe that adapts the battery charge in accordance with their operating temperature. The battery efficiency is assessed by accurately measuring the internal resistance (with 0.1 Ohm resolution) of the batteries in such a way as to signal any decrease in efficiency that might jeopardize the system functionality in the event of mains failure.

The CPU contained in the innovative Switching module is the core of the apparatus and is capable of supervising all of its parameters (internal temperature, current supplied, output voltage, battery parameters, dispersion to earth) and guarantees a product of the highest quality.

SPS24060G / SPS24160G

STAND-ALONE POWER-SUPPLY STATIONS

CE - CPR EN54-4 EN12101-10



SPS24060G and SPS24160G (respectively 1.5A and 4A) with LCD command screen for viewing the events log or fault details (low battery, mains failure, dispersion to earth, etc.) and the current draw of each output; provides 3 individually protected outputs with 4A current limit.

SPS24060S / SPS24160S

POWER-SUPPLY STATIONS CONNECTABLE TO THE LOOP

CE - CPR EN54-4 EN12101-10



SPS24060S and SPS24160S power-supply stations (respectively 1.5A and 4A) with status LEDs, fault output, mains fault output, single power output. Can be used as a stand-alone device or connected directly to the loop of an addressable control panel (Inim protocol). Thanks to its loop interface, it is recognized by the control panel as being a power station and therefore becomes completely and automatically supervised thus reporting all signals to the control panel.

The SPS24060x versions are capable of supplying up to 1.5 A @ 27.6 V and provide housing for two 12 V – 7 Ah batteries; the SPS24160x versions are capable of supplying up to 4 A @ 27.6 V and provide housing for two 12 V – 17 Ah batteries.

TECHNICAL SPECIFICATIONS	SPS24060G	SPS24160G	SPS24060S	SPS24160S
Internal switching power-supply module:	1.5 A @ 27.6 V	4 A @ 27.6 V	1.5 A @ 27.6 V	4 A @ 27.6 V
Input voltage:	230 V~ -15% +10%, 50-60 Hz			
Maximum current draw 230V~:	0.5 A	1.1 A	0.5 A	1.1 A
Output voltage:	27.6 V DC nominal - range from 18 a 27.6 V DC			
Stability:	higher than 1%			
LCD screen	Yes		No	
Ancillary power outputs, each short-circuit protected and 4 A current limited:	3		1	
Tamper/Fault signalling relay output:	1		2	
Built-in battery charger with battery supervision:	Yes			
Battery housing:	2 x 7 Ah 12 V	2 x 17 Ah 12 V	2 x 7 Ah 12 V	2 x 17 Ah 12 V
Dimensions (HxWxD):	322 x 324 x 86	497 x 380 x 97	322 x 324 x 86	497 x 380 x 97
Weight (without battery):	2.8 Kg	6 Kg	2.8 Kg	6 Kg
Loop connection capability:	No	No	Yes	Yes
RS485 BUS connection capability:	Yes (SmartLoop, SmartLine and Smart-Light control panels)			No



IPS24060G - IPS24160G

SWITCHING MODULES

 CE - CPR  EN54-4



The IPS24060G and IPS24160G switching modules, included in the power supply stations described above and in various models of Inim control panels, are also supplied separately as spare parts or for those applications where a complete power supply station is not required. The modules include an independent battery-charge circuit.

NOTE: To reach compliance with the EN54-4 standard, only the switching modules need to be integrated with a device capable of providing visual indications in the event of a fault, normally the control panel or power supply station.

TECHNICAL SPECIFICATIONS		SPS24060G	SPS24160G
Input voltage:		230 V~ -15% +10%, 50-60 Hz	
Maximum current draw 230 V~:		0.5 A	1.1 A
Output voltage:		from 18 to 27.6 V DC	
Maximum output current ripple:		1%	
Battery shutdown tension:		19 V	
Maximum output current	total:	2.1 A	5.2 A
	for external load:	1.5 A	4 A
	for battery load:	0.6 A	1.2 A
Battery housing:		2 x 7 Ah 12 V YUASA NP-12FR	2 x 17 Ah 12 V YUASA NP-12FR
Unreplaceable protection fuse (F1):		T 3, 15 A 250 V	
Maximum internal resistance of battery:		2.7 Ohm	1 Ohm
Operating temperature:		-5° ... +40° C	
Dimensions (HxWxD):		132 x 42 x 87 mm	200 x 51 x 99 mm
Weight (without battery):		450 g	800 g

BPS24060G - BPS24160G

SWITCHING MODULES HOUSED IN METAL ENCLOSURE



The BPS24060G and BPS24160G "IN BOX" versions consist of the IPS24060 and IPS24160 switching modules housed in a metal box without external indications. The Box is capable of containing the backup batteries that the switching modules are able to recharge and monitor.

NOTE: To achieve compliance with the EN54-4 standard, only the switching modules need to be integrated with a device capable of providing visual indications in the event of a fault, normally the control panel or power supply station



Hold open fire door electromagnets

Besides signalling the outbreak of fire, one of the main functions of automatic fire-detection systems is to restrict the fire by releasing fire doors normally held open by electromagnetic holders. This section describes a series of electromagnetic locks for holding fire doors open and releasing them in the event of fire, the different models adapt to various types of doors.

S1 SERIES

ELECTROMAGNETIC DOOR HOLDERS WITHOUT RELEASE BUTTON

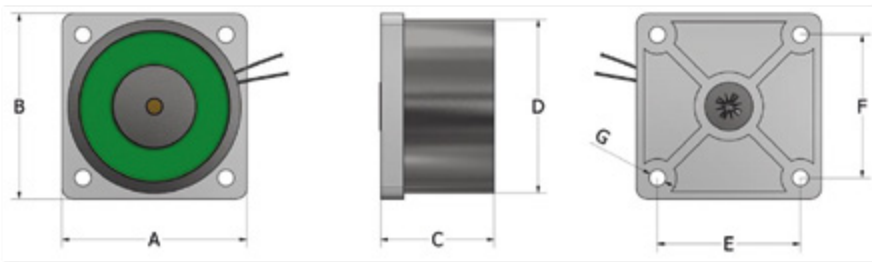

Electromagnetic door holders for applications where a release button and IP protection are not required. The 24V powered door holders of the S1 series are available in different models with various holding forces (50, 100, 150 Kg), Connection on free wires or terminals, supplied with adjustable counterplate for door-leaf opening or with fixed counterplate for sliding doors, in plastic or steel.

DIMENSIONS (MM)

MODEL	HOLDING FORCE	MA	V	FIXTURE	MATERIAL	SENSOR	A	B	C	D	E	F	G	#
S10060_01	500 n / 50 Kg	60	24 V DC	Wire	Plastic	No	68	68	30	50	52	52	6 ø	S01060
S10060_02	500v n / 50 Kg	60	24 V DC	Wire	Plastic	No	68	68	30	50	52	52	6 ø	S02060
S10110_01	1000 n / 100 Kg	100	24 V DC	Wire	Plastic	No	68	68	40	60	52	52	6 ø	S01110
S10110_02	1000 n / 100 Kg	100	24 V DC	Wire	Plastic	No	68	68	40	60	52	52	6 ø	S02110
S10140_02	1500 n / 150 Kg	100	24 V DC	Wire	Steel	No	75	75	40	70	60	60	6 ø	S02160
S10140_H2	1500 n / 150 Kg	100	24 V DC	Wire	Steel	No	75	75	40	70	60	60	6 ø	SH2160
S13060_01	500 n / 50 Kg	60	24 V DC	Terminal	Plastic	No	68	68	30	50	52	52	6 ø	S01060
S13060_02	500 n / 50 Kg	60	24 V DC	Terminal	Plastic	No	68	68	30	50	52	52	6 ø	S02060
S13110_05	1000 n / 100 Kg	100	24 V DC	Terminal	Steel	No	68	68	40	60	52	52	6 ø	S05110
S13140_02	1500 n / 150 Kg	100	24 V DC	Terminal	Steel	No	75	75	40	70	60	60	6 ø	S02160
S13140_H2	1500 n / 150 Kg	100	24 V DC	Terminal	Steel	No	75	75	40	70	60	60	6 ø	SH2160

FEATURES OF SUPPLIED COUNTERPLATES

MODEL	ADJUSTABLE	SHOCK DAMPER	MATERIAL
S01060	YES	YES	PLASTIC
S02060	NO	YES	PLASTIC
S01110	YES	YES	PLASTIC
S02110	NO	YES	PLASTIC
S02160	NO	YES	STEEL
SH2160	NO	YES	STEEL
S01060	YES	YES	PLASTIC
S02060	NO	YES	PLASTIC
S05110	NO	YES	STEEL
S02160	NO	YES	STEEL
SH2160	NO	YES	STEEL

S2 SERIES

ELECTROMAGNETIC DOOR HOLDERS WITH RELEASE BUTTON, PROTECTION CIRCUIT AND ABS COVER

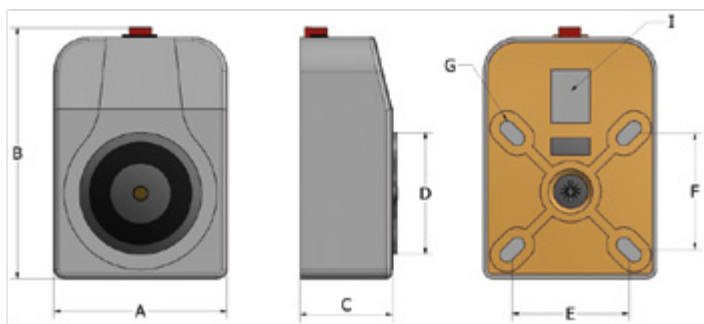

Electromagnetic door holders for applications where the release button and a stylish look are required. The 24V powered S2 series door holders include a protection circuit (diode in-series to polarize the coil and energy recovery counter-diode) and are available in different models with various holding forces (50, 100 Kg). Connection via terminals, supplied with adjustable counterplate, in black or white plastic, with or without door status sensor. Floor-mount brackets, wall-mount extensions and telescopic extensions are available as accessory items.

DIMENSIONS (MM)

MODEL	HOLDING FORCE	MA	V	FIXTURE	COLOUR	SENSOR	A	B	C	D	E	F	G	I	#
S20050B01	500 N / 50 Kg	60	24 V DC	Terminal	White	No	72	105	40	50	52	52	6,5x12	16x22	S01060
S20050N01	500 N / 50 Kg	60	24 V DC	Terminal	Black	No	72	105	40	50	52	52	6,5x12	16x22	S01060
S20110B01	1000 N / 100 Kg	100	24 V DC	Terminal	White	No	72	105	52	60	52	52	6,5x12	16x22	S01110
S20110N01	1000 N / 100 Kg	100	24 V DC	Terminal	Black	No	72	105	52	60	52	52	6,5x12	16x22	S01110
S29050B01	500 N / 50 Kg	60	24 V DC	Terminal	White	Yes	72	105	40	50	52	52	6,5x12	16x22	S01060
S29050N01	500 N / 50 Kg	60	24 V DC	Terminal	Black	Yes	72	105	40	50	52	52	6,5x12	16x22	S01060

= COUNTERPLATE SUPPLIED - ADJUSTABLE SWIVEL, SHOCK DAMPER, IN PLASTIC

S3 SERIES

ELECTROMAGNETIC DOOR HOLDER WITH EXTENSION AND ROTATING HEAD

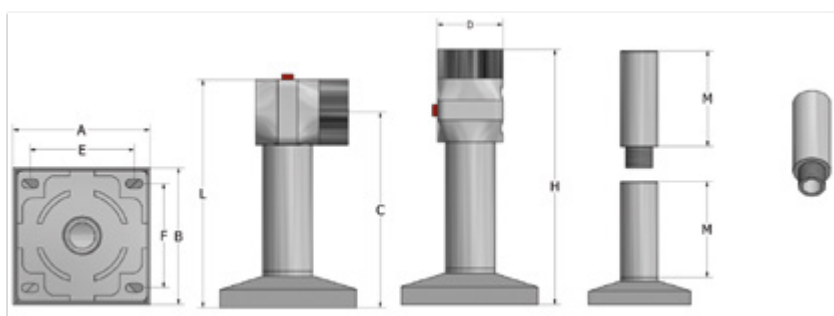

Electromagnetic holders (stops) for ceiling, floor or wall installations, can be rotated with ease, height and length adjustable thanks to the accessory extension, complete with release button. The 24V powered S3 series holders include a protection circuit (diode in-series to polarize the coil and energy recovery counter-diode) and are supplied with an adjustable counterplate, are available in different models with various holding forces (50 or 100 Kg). Connection via terminals, in black or white plastic.

DIMENSIONS (MM)

MODEL	HOLDING FORCE	MA	V	FIXTURE	COLOUR	SENSOR	A	B	C	D	E	F	G	H	I	L	MV	#
S30060_01	500 N / 50 Kg	60	24 V DC	Terminal	Black	No	105	105	122	50	80	80	6,5x12	185	20	150-165	100	S01060
S30110_01	1000 N / 100 Kg	100	24 V DC	Terminal	Black	No	105	105	122	50	80	80	6,5x12	196	20	150-165	100	S01110

= COUNTERPLATE SUPPLIED - ADJUSTABLE SWIVEL, SHOCK DAMPER, IN PLASTIC



S5 SERIES

ELECTROMAGNETIC DOOR HOLDERS WITH RELEASE BUTTON, PROTECTION CIRCUIT AND ABS COVER

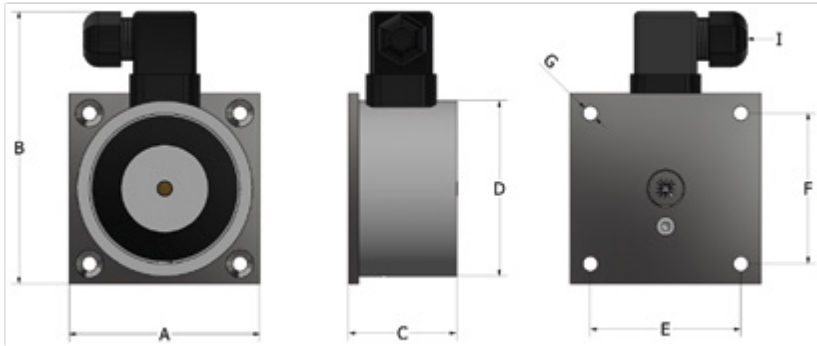

Electromagnetic door holders (stops) with 150 Kg holding force with galvanized steel base, available with IP00 or IP65 protection grade (coil incorporated in resin) or IP67 (coil incorporated in resin and magnetic coupling surface treated for critical environments such as passenger ships) and no release button. The 24V powered S5 series door holders include a protection circuit (diode in-series to polarize the coil and energy recovery counter-diode) and are supplied with a fixed counterplate and shock damper in stainless steel.

DIMENSIONS (MM)

MODEL	HOLDING FORCE	MA	V	FIXTURE	IP	SENSOR	A	B	C	D	E	F	G	I	#
S50140_02	1500 N / 150 Kg	100	24 V DC	TERMINAL	IP00	NO	75	115	43	70	60	60	Ø 5.5	PG11	S02160
S50140_H2	1500 N / 150 Kg	100	24 V DC	TERMINAL	IP00	NO	75	115	43	70	60	60	Ø 5.5	PG11	SH2160
S50160_02	1500 N / 150 Kg	100	24 V DC	TERMINAL	IP65	NO	75	115	43	70	60	60	Ø 5.5	PG11	S02160
S50160_H2	1500 N / 150 Kg	100	24 V DC	TERMINAL	IP65	NO	75	115	43	70	60	60	Ø 5.5	PG11	SH2160
S59150_02	1500 N / 150 Kg	100	24 V DC	TERMINAL	IP67	NO	76	115	43	70	60	60	Ø 5.5	PG11	S02150
S59150_H2	1500 N / 150 Kg	100	24 V DC	TERMINAL	IP67	NO	76	115	43	70	60	60	Ø 5.5	PG11	SH2150

= COUNTERPLATE SUPPLIED - NON SWIVEL, SHOCK DAMPER, IN STEEL

EXM SERIES

ATEX CERTIFIED ELECTROMAGNETIC DOOR HOLDERS FOR HAZARDOUS ENVIRONMENTS WITH HIGH RISK OF EXPLOSION

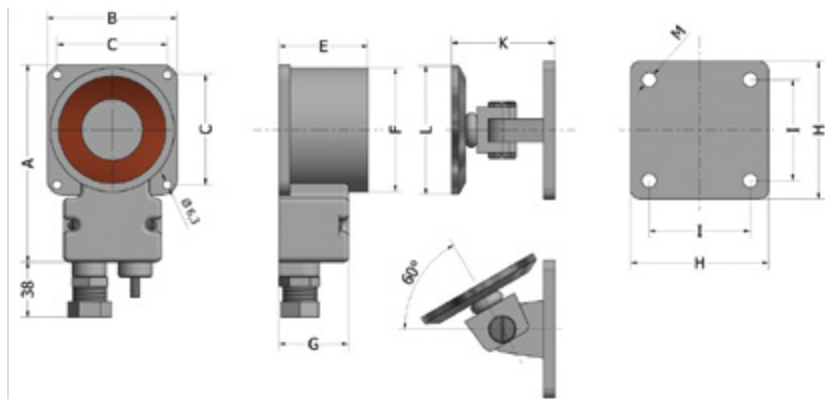

Electromagnetic door holders (stops) for environments with a high risk of explosion, the nominal holding force is guaranteed by use of an adjustable GH counterplate (supplied). The electromagnets are certified in accordance with protection class II T6 II2G ml EX1, 2 (gas, mist, steam). EX II2 D TDA21 IP65 T80 °C, for use in zone 21, 22 (dust). Holding force 65, 130 or 200 Kg depending on the model, connection via standard (1m cable included).

DIMENSIONS (MM)

MODEL	HOLDING FORCE	mA	V	FIXTURE	SENSOR	A	B	C	D	E	F	G	H	I	K	L	#
EXM-650	65 Kg	45	24 V DC	1m CABLE	NO	113	66	52	54	42	Ø 54	38	60	44	50	Ø 56	GH-6
EXM-1300	130 Kg	65	24 V DC	1m CABLE	NO	138	86	52	70	64	Ø 81	45	80	60	62	Ø 86	GH-13/20
EXM-2000	200 Kg	160	24 V DC	1m CABLE	NO	138	86	52	70	64	Ø 81	45	80	60	62	Ø 86	GH-13/20

= COUNTERPLATE SUPPLIED - NON SWIVEL, SHOCK DAMPER, IN STEEL



Counterplates

The adjustable counterplates are supplied with electromagnetic door holders, but are also available as separate items.

S01 SERIES COUNTERPLATES

ADJUSTABLE COUNTERPLATES FOR ELECTROMAGNETIC DOOR HOLDERS



The counterplates of the S01 series use a steel disc mounted on a special shock damper capable of absorbing part of the impact caused by the opening of the door. The elasticity of the shock damper also allows for perfect alignment of the disc to the magnet.

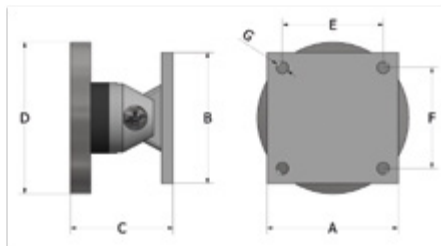

DIMENSIONS (MM)

MODEL	HOLDING FORCE	SHOCK DAMPER	ADJUSTABLE	DISC MATERIAL	BASE MATERIAL	DIMENSIONS (MM)							
						A	B	C	D	E	F	G	I
S01060_00	500 N / 50 Kg	YES	YES	STEEL	PLASTIC	65	65	46	55	50	50	Ø 6	PG11
S01110_00	1000 N / 100 Kg	YES	YES	STEEL	PLASTIC	65	65	7	65	50	50	Ø 6	PG11

S02, SH2, S00 SERIES COUNTERPLATES

ADJUSTABLE COUNTERPLATES FOR ELECTROMAGNETIC DOOR HOLDERS



The counterplates of the S02, SH2, S00 series use a steel disc mounted on a special shock damper capable of absorbing part of the impact caused by the opening of the door. The elasticity of the shock damper also allows for perfect alignment of the disc and magnet.

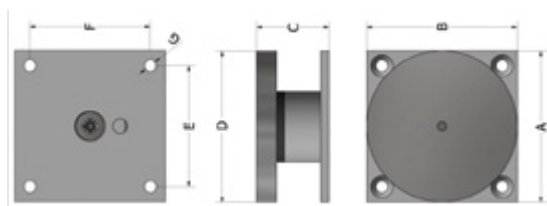

DIMENSIONS (MM)

MODEL	HOLDING FORCE	SHOCK DAMPER	ADJUSTABLE	DISC	BASE	DIMENSIONS (MM)						
						A	B	C	D	E	F	G
S02060_00	500 N / 50 Kg	YES	NO	STEEL	PLASTIC	65	65	20	55	52	52	Ø 6
S02110_00	1000 N / 100 Kg	YES	NO	STEEL	PLASTIC	65	65	20	65	52	52	Ø 6
S02150_00	1500 N / 150 Kg	YES	NO	STEEL	AISI316L STEEL	75	75	20	75	60	60	Ø 6
SH2150_00 (ALTO)	1500 N / 150 Kg	YES	NO	STEEL	AISI316L STEEL	37	75	37	75	60	60	Ø 6
S02160_00	1500 N / 150 Kg	YES	NO	STEEL	STEEL	37	75	20	75	60	60	Ø 6
SH2160_00 (ALTO)	1500 N / 150 Kg	YES	NO	STEEL	STEEL	37	75	37	75	60	60	Ø 6

S05110_00	1000 N / 100 Kg	YES	NO	STEEL	STEEL	Compact fixed-anchor shock damper for S13110 100 Electromagnetic Door Holder						
-----------	-----------------	-----	----	-------	-------	--	--	--	--	--	--	--



30050_061

EXTENSION ROD FOR S3 SERIES ELECTROMAGNETIC DOOR HOLDERS



The 30050_061 extension rod is suitable for all S3 models and provides an extension of 100 mm. It can also be used as an extension for the S03130 bracket. The simple assembly method offers quick installation at all times, even when the electromagnet is already installed, for intermediate measurements it is possible to shorten the rod by cutting it to size.

S03000-N / ...

PAINTED L-SHAPED BRACKET FOR FIXING TO THE FLOOR THE ELECTROMAGNETIC HOLDERS TYPE S1, S2, S6



Painted steel plate, for fixing to the floor electromagnetic door holders for the model S2 with 50 or 100 Kg holding force. Black or white depending on the model.

S03000-N
S03000-W

L-shaped bracket, in black painted
L-shaped bracket, in white painted

A	B	C	D	E	F	G
72	48	135	∅10	60	32	∅6

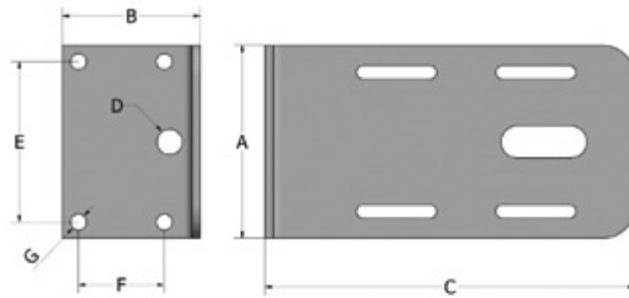

S03130

130 MM EXTENSION FOR ELECTROMAGNETIC DOOR HOLDERS TYPE S1, S2, S6



Extension S03130 for S2 electromagnetic door holders, used in cases where the electromagnet installed on the wall is too far from the door to be held. The extension allows an increase in the distance between the electromagnet and the wall of from 45 to 130 mm and, by adding the accessory rod, reach 230 mm. For medium distances, the rod can be shortened by cutting it to size, the S03130 extension is UNI EN 1155 certified for all S2 electromagnets with 50 or 100 Kg holding force.

A	B	C	D	E	F	G	L	E	F
105	105	130	20	80	80	6,5x12	100	52	52

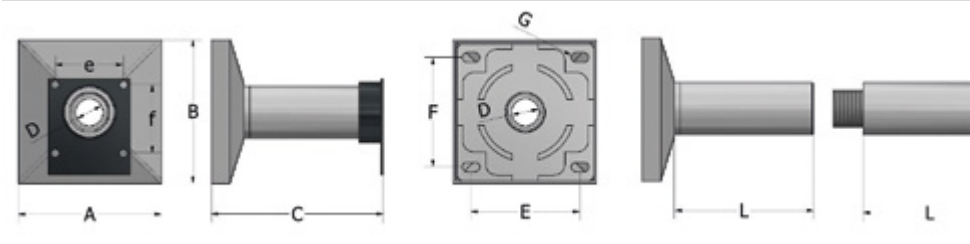

S03150

TELESCOPIC 150-220 MM EXTENSION FOR ELECTROMAGNETIC DOOR HOLDERS TYPE S1, S2, S6,
AND COUNTERPLATES TYPE S01, S02



S03150 telescopic extension for S2 electromagnetic door holders, used in cases where the electromagnet, installed on the wall, is too far from the door to be held. The extension allows an increase in the distance between the electromagnet and the wall of from 150 to 220mm.

A	B	C	D	E	F	G	E	F	F
65	65	100	150-220	65	65	5.5	52	52	52

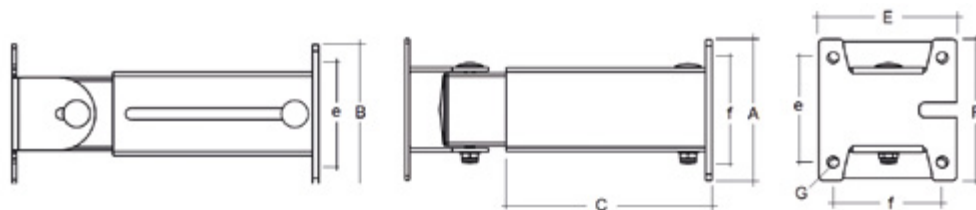



Detectors test

During commissioning and periodic testing of the systems, as prescribed by the reference standard, it is necessary to test the individual detectors in order to verify their efficiency. The following articles allow the operator to carry out test operations on the detectors quickly and easily.

SOLOA10 / SOLOA10S

TESTER AEROSOL FOR SMOKE DETECTORS



Spray can containing aerosol for testing smoke detectors, a non-flammable product specifically designed to test the operation of the detectors without making them dirty or compromising their functionality. Thanks to its special formula, it guarantees rapid activation and equally rapid cleaning of the chamber after activation, minimizing the time required for the detector test. This article is compatible with the SOLO330 dispenser.

- SOLOA10** 150 ml spray canister
- SOLOA10S** 250 ml spray canister

SMOKESABRE

SMOKE TEST AEROSOL WITH HAND HELD TELESCOPIC POLE



Spray can for smoke detector test, suitable for hand held use, include a telescopic dispenser for better smoke flow direction. 150ml spray canister.

SOLO 330

SOLO A10 AEROSOL DISPENSER



Can house inside SOLO A10 or SOLO A10S spray canisters (not included) and allows the delivery of the aerosol over the detector by simply exerting light pressure from the bottom upwards. Combined with the telescopic extension shown below, it allows the testing of detectors positioned as high up as 9m.

SOLO200

DETECTORS REMOVAL/REPLACEMENT TOOL



It allows you to hook the detector that is mounted to the ceiling and detach it from its base, this tool is indispensable for cleaning operations or replacement of detectors as it eliminates the need to climb ladders. Combined with the telescopic extension shown below, it allows the removal of detectors positioned as high up as 9m.

SOLO461

CORDLESS HEAT DETECTORS TESTER



Battery operated device for testing heat detectors, it allows quick and efficient testing of the detector operating capacity. Combined with the telescopic extension shown below, it allows the testing of detectors positioned as high up as 9m.



SOLO365

TEST KIT FOR SMOKE DETECTORS



New SOLO365 is a smoke detector tester kit based on a cartridge for aerosol generator and no longer need spray can. The appliance operates using a rechargeable battery, there is a USB socket on the battery pack for recharging purposes. The kit includes:

- SOLO 356 Head Unit
- SOLO 370 Lithium Ion Battery Pack
- SOLO 371 Smoke Generator
- SOLO ES3 Smoke Cartridge

SOLO365	Test kit for smoke detectors
E63-12PACK-001	SOLO365 Smoke Cartridge (pack of 12)
SOLO370-1PACK-001	Lithium Ion Battery Pack

TESTIFIRE 1001-101

TEST KIT FOR SMOKE AND HEAT DETECTORS



Test kit for smoke and heat detectors, one device for both technologies. The smoke stimulus comes in non-pressurized capsules thus avoids the inconvenience of carrying pressurized aerosols. The kit includes:

- TestFire 1000-001 appliance
- TS3-001 Smoke test capsule
- 2 poles/battery
- fast charger

TESTIFIRE 1001-101	TEST kit for smoke and heat detectors
TS3-6PACK-001	TS3 capsule for smoke generation (pack of 6)
SOLO770-001	Cylindrical rechargeable battery replacement

TESTIFIRE 6001-101

TEST KIT FOR SMOKE AND HEAT DETECTORS



The kit includes all the items mentioned in the 1001-101 kit plus:

- 4.5 m fibreglass telescopic pole
- 200-001 tool for the removal of detectors from bases
- 610-001 protective carrying bag

TESTIFIRE 6001-101	TEST kit for smoke and heat detectors
TS3-6PACK-001	TS3 capsule for smoke generation (pack of 6)
SOLO770-001	Cylindrical rechargeable battery replacement

AND TELESCOPIC EXTENSIONS



SOLO101
1.13 m single pole: Reaches detectors installed at a height of 2.5m.

SOLO108
2.5 telescopic pole: Extends from 1.26m to 2.5 m by means of 2 easy-lock telescopic sections. Reaches detectors installed up to a height of 4 m. It can be combined with an additional SOLO 101 pole in order to reach detectors installed higher.

SOLO100
4.5 m telescopic pole: Extends from 1.26m to 4.5 m by means of 4 easy-lock telescopic sections. It can reach detectors installed up to a height of 6m and can be further extended by attaching a maximum of 3 SOLO 101 poles to reach detectors installed as high up as 9m.



Accessories

The products shown on this page are useful accessories for enhancing fire detection systems and their installation. Among these are plastic covers, adapters for external ducts and much more.



REL1INT
SINGLE RELAY BOARD

Converts supervised or open-collector outputs into a dry contacts. Operates at 12 or 24 V (selected by means of a jumper). Provides 4 mounting locations, board dimensions 45x35 mm.



STD241201
24 V DC/ 12 V DC STEP-DOWN SWITCHING CONVERTER

Converts voltage from 24V down to 14V, suitable for feeding 12V devices (outdoor sounder/ flashers, diallers, etc.) directly from fire the control panel. Based on switching technology, this highly efficient device produces low heat output. Maximum output current 1 A.



IL0010
REMOTE INDICATOR

Remote indicator. LED repeater that replicates the signal generated by a detector in alarm status.



S/KARI MR
LED REPEATER FOR CEILING OR FLOOR INSTALLATION

LED repeater for ceiling or floor installation Super bright LED light. 3 V dc, 24 V dc power-supply voltage. Structure in polycarbonate transparent white. Light diffuser lens 'FIRE' sign in Red. IP 42 Protection grade



IACPP10
COVER FOR INDOOR MANUAL ALARM CALL-POINTS, IP54

It consists of a transparent polycarbonate enclosure that covers the call point and is sealed by gaskets which keep out dust, grime and water. Access to the device is gained by simply lifting the cover.



IACPP20
COVER FOR OUTDOOR MANUAL ALARM CALL-POINTS, IP54

It consists of a transparent polycarbonate enclosure that covers the call point and is sealed by gaskets which keep out dust, grime and water. Access to the device is gained by simply lifting the cover. A battery-powered beeper activates automatically when the cover is lifted, in order to dissuade malicious alarms.



INLINEFMF
FLUSH MOUNTING KIT

Flush mounting kit for SmartLine020, SmartLight and Previdia Compact "S" control panels range. It consists of two L shaped bracket and a front panel metal made.



INPROTCP
Metal protection frame for manual call points.



CTS01
Sign in aluminum indicating the presence of a manual call point, 160 x 160 mm.



CTS02
Aluminum sign board indicating fire alarm sounder presence, 160 x 160 mm.

Connection cables



LINK232F9F9
SERIAL CABLE
RS232 connection cable between a PC and Inim control panels.



LINKUSBAB
USB CABLE
USB connection cable between a PC and SmartLoop control panels.



LINKUSB232CONV
CABLE WITH RS232 - USB CONVERSION ADAPTER
RS232 - USB connection cable between PC and Inim control panels.



PROBE-TH
THERMAL PROBE
Thermal probe for battery charge optimization.



MINI USB CABLE
Connection cable from USB to Mini USB

SPOTLED



HP320





Emergency lighting

See the
online
section



Inim series emergency-lighting and signalling lamps are designed for direct connection to the detection loop* of Previdia and SmartLoop control panels. The connection of Harper lamps to Previdia and SmartLoop fire detection and signalling control panels permits:

- Turn On/Off of the emergency lamps in function of the status of the detection system, in this way it is possible to keep the lamps in Low-light mode or Off mode during normal conditions and activate them at full intensity in the event of an alarm
- Activation and deactivation of the emergency warning lamps in function of detected alarms, thus permitting appropriate signalling of the most effective escape route
- Adjustment of lamp-light intensity during non-emergency conditions (Previdia only)
- Compliance with lamp maintenance cycles, the control panel is capable of managing various tests on groups of lamps (functional tests and internal battery life tests) and of storing the respective data; detailed test reports can be generated during these maintenance sessions in compliance with the reference standard (EN50172)

The light source of the Inim emergency light series is an optimal blend of new generation long-life LEDs rated to over 50 thousand hours, high light output, low energy consumption and, thanks to an exclusive patented optical lighting design, highly effective glare-free technology that complies with all regulations regarding photobiological safety. The durability and performance of Harper emergency lights is further enhanced by new LiFePO₄ long-life batteries which are smaller and more environment-friendly than standard nickel-cadmium or nickel-metal hydride batteries.

For further details and the complete list of items, please consult the dedicated catalogue.

*Inim series lamps use the connection with the loop for data exchange only and not for their power supply, therefore, in addition to the connection to the loop a connection to the electrical network is required for each lamp.

Product name	VR	VERALED
	DV	DIVA
	DX	DEXIA
	HP100	Harper 100
	HP200	Harper 200
	HP320	Harper 320
	HP330	Harper 330
	SP	SPOTLED
Version*	S	Standard
	A	Self-test
	B	BUS Supervised
	L	Central-battery
Maintained (M) – Non-maintained (NM)**	E	Non-Maintained
	A	Maintained
Power	08	W
	11	W
	18	W
	24	W
	36	W
Duration	01	1 hour
	15	1.5 hours
	02	2 hours
	03	3 hours
	04	4 hours
	05	5 hours
	06	6 hours
	07	7 hours
IP Protection grade	40	IP40
	42	IP42
	65	IP65

NOTE

*The only versions that can be connected to the control panel Loop are the 'B: BUS Supervision' versions.

**The only versions that can be switched on by the control panel, also during NON-emergency conditions (mains present) are the Permanent (BA) versions.



DIVA
EMERGENCY LUMINAIRES

55015 60598-1 60598-2-22
61000-3-2 61000-3-3 61347-1 61347-2-7 61547 62471



LED emergency lamps with a compact minimalist design. Dedicated terminal for the inhibition function and dedicated terminal for the rest mode function.

TECHNICAL SPECIFICATIONS

Installation:	Wall, Ceiling	IP protection grade:	IP42, IP65 (*)
Power supply voltage:	220 / 230 V AC, 50-60 Hz	IK protection grade:	IK07
Battery:	LiFePO ₄ 3.2 V	Colour:	RAL9003 White
Isolation class:	II	Operating temperature:	0°C ... +40°C
Light source:	LED	Dimensions:	230 x 100 x 22.5 mm
Colour temperature:	6000K		
Diffuser:	Ultrasound-welded PC		

ORDER CODES	Power ⁽³⁾	Duration	Battery LiFePO ₄ 3.2V [Ah]	Maintained (M) – Non-maintained (NM)	MED. FLUX [lm] N/M	MED. FLUX [lm] M	Recharge
DVBA080342	8W	3h	1.5	N/M-M	130	130	6h
DVBA110242	11W	2h	1.5	N/M-M	180	180	6h
DVBA110342	11W	3h	2 x 1.5	N/M-M	180	180	12h
DVBA180142	18W	1h	1.5	N/M-M	320	180	6h
DVBA180242	18W	2h	2 x 1.5	N/M-M	320	180	12h
DVBA241542	24W	1.5h	2 x 1.5	N/M-M	400	220	12h

⁽³⁾ Indicative power for the comparison with fluorescent tube

DEXIA
EMERGENCY LUMINAIRES

55015 60598-1 60598-2-22
61000-3-2 61000-3-3 61347-1 61347-2-7 61547 62471



High-flux LED emergency lamp designed for industrial environments, department stores and car parks.

TECHNICAL SPECIFICATIONS

Installation:	Wall, ceiling, surface/false ceiling mount	IP protection grade:	IP42, IP65 (*)
Power supply voltage:	220/230Vac, 50-60Hz	IK protection grade:	IK07
Battery:	LiFePO ₄ 3.2V	Colour:	RAL9003 White
Isolation class:	II	Operating temperature:	0°C ... +40°C
Light source:	LED	Dimensions:	322 x 140 x 50 mm
Colour temperature:	6000K		
Diffuser:	Ultrasound-welded PC		

ORDER CODES	Power ⁽³⁾	Duration	Battery LiFePO ₄ 3.2V [Ah]	Maintained (M) Non-maintained (NM)	MED. FLUX [lm] N/M	MED. FLUX [lm] M	Recharge
DXBA360142	36W	1h-1.5h-2h-3h	2 x 3.3	N/M-M	1300-1000-840-640	1000	12h
DXBA240142	24W	1h-1.5h-2h-3h	3.3	N/M-M	700-550-450-350	550	12h

⁽³⁾ Indicative power for the comparison with fluorescent tube



HP100
EMERGENCY LUMINAIRES

55015
 60598-1
 60598-2-22
 61000-3-2
 61000-3-3
 61347-1
 61347-2-7
 61547
 62471



Minimal and compact design emergency lamp characterized by quick and easy installation. The use of new generation LED technology with exclusive patented optics guarantees high light flow and reliability over time.

TECHNICAL SPECIFICATIONS

Installation:	Wall, Ceiling	IP protection grade:	IP42, IP65 (*)
Power supply voltage:	220/230Vac, 50-60Hz	IK protection grade:	IK07
Battery:	LiFePO ₄ 3.2V	Colour:	RAL9003 White
Isolation class:	II	Operating temperature:	0°C ... +40°C
Light source:	LED	Dimensions:	255 x 122 x 38 mm
Colour temperature:	6000K		
Diffuser:	Ultrasound-welded PC		

ORDER CODES	Power ⁽³⁾	Duration	Battery LiFePO ₄ 3.2V [Ah]	Maintained (M) Non-maintained (NM)	MED. FLUX [lm] N/M	MED. FLUX [lm] M	IP	Recharge
HP100BE110140	11 W	1h-1.5h	1.5	N/M	130-95	-	IP40	6h
HP100BE240140	24 W	1h	1.5	N/M	250	-	IP40	6h
HP100BE110340	11 W	3h-4h	3.3	N/M	130-95	-	IP40	12h
HP100BE240340	24 W	3h	3.3	N/M	250	-	IP40	12h
HP100BA110140	11 W	1h-1.5h	1.5	N/M-M	130-95	60	IP40	6h
HP100BA240140	24 W	1h	1.5	N/M-M	250	120	IP40	6h
HP100BA110340	11 W	3h-4h	3.3	N/M-M	130-95	60	IP40	12h
HP100BA240340	24 W	3h	3.3	N/M-M	250	120	IP40	12h
HP100BE110165	11 W	1h-1.5h	1.5	N/M	130-95	-	IP65	6h
HP100BE240165	24 W	1h	1.5	N/M	250	-	IP65	6h
HP100BE110365	11 W	3h-4h	3.3	N/M	130-95	-	IP65	12h
HP100BE240365	24 W	3h	3.3	N/M	250	-	IP65	12h
HP100BA110165	11 W	1h-1.5h	1.5	N/M-M	130-95	60	IP65	6h
HP100BA240165	24 W	1h	1.5	N/M-M	250	120	IP65	6h
HP100BA110365	11 W	3h-4h	3.3	N/M-M	130-95	60	IP65	12h
HP100BA240365	24 W	3h	3.3	N/M-M	250	120	IP65	12h

⁽³⁾ Indicative power for the comparison with fluorescent tube



HP200
EMERGENCY LUMINAIRES

55015
 60598-1
 60598-2-22
 61000-3-2
 61000-3-3
 61347-1
 61347-2-7
 61547
 62471



Minimal and compact design emergency lamp characterized by quick and easy installation. The use of new generation LED technology with exclusive patented optics guarantees high light flow and reliability over time.

TECHNICAL SPECIFICATIONS

Installation	Wall, Ceiling	IP protection grade	IP42, IP65 (*)
Power supply voltage	220 / 230 V AC, 50-60 Hz	IK protection grade	IK07
Battery	LiFePO ₄ 3.2 V	Colour	RAL9003 White
Isolation class	II	Operating temperature	0°C ... +40°C
Light source	LED	Dimensions	319 x 137 x 38 mm
Colour temperature	6000 K		
Diffuser	Ultrasound-welded PC		

ORDER CODES	Power ⁽³⁾	Duration	Battery LiFePO ₄ 3.2V [Ah]	Maintained (M) – Non-maintained (NM)	MED. FLUX [lm] N/M	MED. FLUX [lm] M	IP	Recharge
HP200BE180142	18 W	1h-1.5h	1.5	N/M	180-135	-	IP42	6h
HP200BE360142	36 W	1h-1.5h	3.3	N/M	360-270	-	IP42	12h
HP200BE180342	18 W	3h-4h	3.3	N/M	180-135	-	IP42	12h
HP200BE360342	36 W	3h-4h	2 x 3.3	N/M	360-270	-	IP42	24h
HP200BA180142	18 W	1h-1.5h	1.5	N/M-M	180-135	80	IP42	6h
HP200BA360142	36 W	1h-1.5h	3.3	N/M-M	360-270	170	IP42	12h
HP200BA180342	18 W	3h-4h	3.3	N/M-M	180-135	80	IP42	12h
HP200BA360342	36 W	3h-4h	2 x 3.3	N/M-M	360-270	170	IP42	24h
HP200BE180165	18 W	1h-1.5h	1.5	N/M	180-135	-	IP65	6h
HP200BE360165	36 W	1h-1.5h	3.3	N/M	360-270	-	IP65	12h
HP200BE180365	18 W	3h-4h	3.3	N/M	180-135	-	IP65	12h
HP200BE360365	36 W	3h-4h	2 x 3.3	N/M	360-270	-	IP65	24h
HP200BA180165	18 W	1h-1.5h	1.5	N/M-M	180-135	80	IP65	6h
HP200BA360165	36 W	1h-1.5h	3.3	N/M-M	360-270	170	IP65	12h
HP200BA180365	18 W	3h-4h	3.3	N/M-M	180-135	80	IP65	12h
HP200BA360365	36 W	3h-4h	2x3.3	N/M-M	360-270	170	IP65	24h

⁽³⁾ Indicative power for the comparison with fluorescent tube



SPOTLED

EMERGENCY SPOTLIGHT

55015
 60598-1
 60598-2-22
 61000-3-2
 61000-3-3
 61347-1
 61347-2-7
 61547
 62471



Flush mounting emergency spotlight with ultra-slim design and high performance light. It is equipped as standard with a symmetrical and asymmetrical lens.

TECHNICAL SPECIFICATIONS

Installation	False ceiling mount	IP protection grade	IP40
Operating voltage	220 / 230 V AC, 50-60 Hz	IK protection grade	IK07
Battery	LiFePO ₄ 3.2 V	Colour	RAL9003 White
Isolation class	II	Operating temperature	0° ... +40° C
Light source	LED	Diameter	90 mm
Colour temperature	5700 K		
Diffuser	Ultrasound-welded PC		

ORDER CODES

ORDER CODES	Power	Battery LiFePO ₄ 3.2V [Ah]	Maintained (M) Non-maintained (NM)	MED. FLUX [lm] N/M	MED. FLUX [lm] M	Recharge
SPBA240140	1h	1.5	N/M-M	300	220	6h
SPBA240340	3h	2 x 1.5	N/M-M	300	220	12h

CONVERTLED

EMERGENCY LIGHTING KIT

55015
 60598-1
 60598-2-22
 61000-3-2
 61000-3-3
 61347-1
 61347-2-7
 61547
 62471



Electrical power supply for emergency ceiling lights and LED modules. Compatible with all drivers with 6 V DC to 60 V DC output voltage, 2 A max. current. Compatible with 6 V DC to 60 V DC LED modules.

TECHNICAL SPECIFICATIONS

Installation	False ceiling mount	IP protection grade	IP30
Operating voltage	220 / 230 V AC, 50-60 Hz	IK protection grade	IK07
Battery	LiFePO ₄ 3.2 V	Colour	RAL9003 White
Isolation class	II	Operating temperature	0° ... +40° C
Light source	LED	Dimensions	240 x 65 x 26 mm
Colour temperature	5700K	Package contents	packs of 25
Diffuser	Ultrasound-welded PC		

ORDER CODES

ORDER CODES	Output power	Battery LiFePO ₄ 3.2V [Ah]	Duration	Recharge
CNBA01	4 W - 3 W - 2 W - 1,5 W	2 x 1.5	1h - 1.5h - 2h - 3h	12h



VERALED
EMERGENCY LAMP KIT

- ★ 55015
- ★ 60598-1
- ★ 60598-2-22
- ★ 61000-3-2
- ★ 61000-3-3
- ★ 61347-1
- ★ 61347-2-7
- ★ 61547
- ★ 62471



Waterproof LED illumination lamp with emergency conversion kit. Ideal for industrial applications, department stores and car parks.

TECHNICAL SPECIFICATIONS

Installation	Wall, ceiling, lighting busway	IP protection grade	IP65
Operating voltage	220 / 230 V AC, 50-60 Hz	IK protection grade	IK08
Battery	LiFePO ₄ 3.2 V	Colour	Grey
Isolation class	I	Operating temperature	0° ... +50° C
Light source	LED	Dimensions VRBA20	600 x 90 x 95 mm
Colour temperature	5000 K	Dimensions VRBA50	1200 x 90 x 95 mm
Diffuser	Transparent polycarbonate		

ORDER CODES	Power ⁽³⁾	Duration	Battery LiFePO ₄ 3.2V [Ah]	Maintained (M) – Non-maintained (NM)	MED. FLUX [lm] N/M	MED. FLUX [lm] M	IP	Recharge
VRBA20	15 W	1h-1.5h-2h-3h	2 x 1.5	N/M-M	620-500-370-300	1700	IP65	12h
VRBA50	48 W	1h-1.5h-2h-3h	2 x 1.5	N/M-M	620-500-370-300	5100	IP65	12h

⁽³⁾ Indicative power for the comparison with fluorescent tube

HP320
EMERGENCY SIGNALLING LAMPS

- ★ 60598-1
- ★ 60598-2-22
- ★ 62471
- ★ 1838
- ★ 3864-4
- ★ ISO 7010



Signalling lamps for escape routes, compact and flexible. Can be installed in any position via a single bracket (supplied), for visibility distances of 20 meters, pictograms compliant with international standard (ISO7010, to be purchased separately).

TECHNICAL SPECIFICATIONS

Installation	Wall, flag, ceiling, recess, suspended	IP protection grade	IP40
Operating voltage	220 / 230 V AC, 50-60 Hz	IK protection grade	IK07
Battery	LiFePO ₄ 3.2 V	Colour	RAL9003 White
Isolation class	II	Operating temperature	0° ... +50° C
Light source	LED	Dimensions VRBA20	217 x 176.5 x 41 mm
Colour temperature	6000 K	Visibility distance	20m
Diffuser	Transparent polycarbonate		

ORDER CODES	Duration	Battery LiFePO ₄ 3.2V [Ah]	Maintained (M) Non-maintained (NM)	IP PROTECTION GRADE	Recharge
HP320BA000340	3h	1.5	M	IP40	6h



HP330

EMERGENCY SIGNALLING LAMPS

60598-1 60598-2-22 62471 1838 3864-4 ISO 7010



Safety lamps for escape route signalling, compact and versatile, installable in any position via a single bracket, 30m visibility distance, international standard compliant (ISO7010), to be purchased separately.

TECHNICAL SPECIFICATIONS

Installation	Wall, flag, ceiling, recess, suspended	IP protection grade	IP40
Operating voltage	220 / 230 V AC, 50-60 Hz	IK protection grade	IK07
Battery	LiFePO ₄ 3.2 V	Colour	RAL9003 White
Isolation class	II	Operating temperature	0° ... +50° C
Light source	LED	Dimensions VRBA20	322 x 231.5 x 41 mm
Colour temperature	6000 K	Visibility distance	30 m
Diffuser	Transparent polycarbonate		

ORDER CODES

ORDER CODES	Duration	Battery LiFePO ₄ 3.2V [Ah]	Maintained (M) Non-maintained (NM)	IP PROTECTION GRADE	Recharge
HP330BA000140	1h	1.5	M	IP40	6h
HP330BA000340	3h	3.3	M	IP40	12h



Accessories for emergency lighting



OHDVIP65 IP65 KIT FOR DIVA SERIES LAMPS
OHDXIP65 IP65 KIT FOR DEXIA SERIES LAMPS



OHX00GRT
PROTECTIVE METAL GRATING FOR COMPLETE PROTECTION OF THE LAMP BODY

Accessory item for DIVA, DEXIA, HP100, HP200



OHX00BR45
BRACKET FOR INSTALLATION WITH A 45° INCLINATION

Accessory item for DIVA, DEXIA, HP100, HP200



OHBBK
KIT FOR FIXING ON ELECTRIFIED BAR

Accessory item for DIVA, DEXIA, HP100, HP200



OH100BRI
KIT FOR FIXING ON ELECTRIFIED BAR

Accessory item for HP100



OH200BRI
KIT FOR FIXING ON ELECTRIFIED BAR

Accessory item for DEXIA, HP200

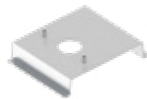

OHX00FCK
PLASTERBOARD AND FALSE CEILING FASTENING KIT

Accessory item for DEXIA, HP200



OHCNTB
TEST BUTTON

Accessory item for CONVERTLED



OH330FCK
KIT FOR INSTALLATION ON A FALSE CEILING
LEAVES ONLY THE SIGNALLING PANEL VISIBLE

Accessory item for HP320, HP330



OH3X0SPK
KIT FOR SUSPENSION INSTALLATION

Accessory item for HP320, HP330



OH3X0GRT
PROTECTIVE METAL GRATING FOR COMPLETE PROTECTION OF THE LAMP BODY

Accessory item for HP320, HP330

Pictograms



OHDVPTK PICTOGRAMS KIT FOR DIVA SERIES LAMPS
OHDXPTK PICTOGRAMS KIT FOR DEXIA SERIES LAMPS

OH100PTDW SAFETY EXIT PICTOGRAM INDICATING DOWN FOR HP100

OH200PTDW SAFETY EXIT PICTOGRAM INDICATING DOWN FOR HP200

OH100PTRG SAFETY EXIT PICTOGRAM INDICATING RIGHT FOR HP100

OH200PTRG SAFETY EXIT PICTOGRAM INDICATING RIGHT FOR HP200

OH100PTLF SAFETY EXIT PICTOGRAM INDICATING LEFT FOR HP100

OH200PTLF SAFETY EXIT PICTOGRAM INDICATING LEFT FOR HP200



OH330PNDW PMMA PANEL + PICTOGRAMS

PMMA panel with pictograms indicating down



OH330PNRL PMMA PANEL + PICTOGRAMS

PMMA panel with pictograms indicating left/right

HEVOLUTO





BMS software

Software for real-time monitoring and control of the status of a building

All Inim control panels are capable of managing the most widely used communication protocols for connection with the control and monitoring software (Building Management Software).

Such protocols (MODBUS, MODBUS On TCP-IP, BACNET, etc.) make it possible to interface the control panels with the larger part of software on the market.

The following pages show some BMS software distributed directly by Inim.





SmartLook

See the
online
section



Software for centralized monitoring and management of fire-detection and intrusion-control systems.

The modularity of the software makes it the best choice for both industrial and commercial applications, such as hotel receptions, conference halls and shopping centres, for monitoring the status of the system and interacting with it. A typical application is the monitoring of several installations located in different buildings or even different places, thus centralizing the management of a distributed system in a single workstation.



The flexibility of the system allows not only the monitoring of all types of fire control panels (addressable and conventional) but also that of SmartLiving series anti-intrusion control panels. In fact, thanks to the easy-to-understand user interface, this software also finds important applications in the home-automation field.

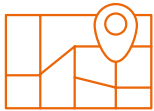

The software uses graphic maps linked together in a tree structure. An arbitrary number of objects can be inserted on each map, such as monitoring elements (detectors, zones, outputs, bells, etc.), links to another map, links to web pages (web interface of a VCR) or execution command buttons. There are also simple self-diagnosis functions that allow verification of the status of communication between software, control panels and devices.



The operator can interact with the system in real time, making it possible to check the status of the detectors, carry out reset, bypass and output activation operations, etc., as well as check instantly the structure thanks to the integrated video function which allows the connection to cameras and DVRs with web interface on the IP network.



The SmartLook software is capable of importing the system configuration by reading it directly on the control panel, or importing it from the database of the SmartLeague, Prime/STUDIO and Previdia/STUDIO software, thus reducing programming time considerably.





CLIENT LICENCES

- SMARTLOOK/F01L** "Lite" Fire Licence – Licence for the management of one Previdia, SmartLoop or SmartLine fire-detection control panel. Non-expandable licence.
- SMARTLOOK/F01E** Licence for the management of one Previdia, SmartLoop or SmartLine fire-detection control panel. Expandable licence.
- SMARTLOOK/F02E** Licence for the management of two Previdia, SmartLoop or SmartLine fire-detection control panels. Expandable licence.
- SMARTLOOK/F05E** Licence for the management of five Previdia, SmartLoop or SmartLine fire-detection control panels. Expandable licence.
- SMARTLOOK/F10E** Licence for the management of ten Previdia, SmartLoop or SmartLine fire-detection control panels. Expandable licence.
- SMARTLOOK/I01L** "Lite" Intrusion Licence – Licence for the management of one intrusion-control panel from the SmartLiving series. Non-expandable licence.
- SMARTLOOK/I01E** Licence for the management of one intrusion-control panel from the SmartLiving and Prime series. Expandable licence.
- SMARTLOOK/I02E** Licence for the management of two intrusion-control panel from the SmartLiving and Prime series. Expandable licence.
- SMARTLOOK/I05E** Licence for the management of five intrusion-control panel from the SmartLiving and Prime series. Expandable licence.
- SMARTLOOK/I10E** Licence for the management of ten intrusion-control panel from the SmartLiving and Prime series. Expandable licence.



Hevoluto

See the
online
section



PSIM software for the management of building protection systems

Hevoluto is the PSIM (Physical Security Information Management) software that allows centralized management of fire-fighting systems and security systems of one or more sites in a single solution. The data and information deriving from the various monitored platforms are retrieved and reprocessed automatically and continuously; the mapping functions offer instant location of the site where an alarm event occurs, maintaining an overall view of the entire protected structure.

With the Hevoluto PSIM software, risk levels are minimized and response times to dangers are faster.



Client/server
architecture



Integration with
third-party
systems



Camera
management



Compatibility
with AutoCAD
files



Multiscreen
management





SERVER LICENCES

HV-SVLIC1K Includes 1 Operator Client and 1000 data points (anti-intrusion, fire detection and ModBus IP technology) The management of CCTV systems (requires HV-SVIDLIC licence) and access control systems (requires HV-SVACLIC licence).

HV-SVLIC2K Includes 1 Operator Client and 2000 data points (anti-intrusion, fire detection and ModBus IP technology) The management of CCTV systems (requires HV-SVIDLIC licence) and access control systems (requires HV-SVACLIC licence).

HV-SVIDLIC Video Server licence that allows the management of the CCTV system and video sources (IP cameras or DVR/NVR). Does not include camera licences.

HV-SVACLIC Access Control Server licence that allows you to manage the access control systems and gates associated with it. Does not include gate licences.

CLIENT LICENCES

HV-CLI01 Additional licence for 1 Client workstation.

HV-CLI05 Additional licence for 5 Client workstations.

DATAPPOINT LICENCES (Require HV-SVLICxK)

HV-DP120LIC Licence for 128 data points. Requires HV-SVLICxK.

HV-DP240LIC Licence for 256 data points. Requires HV-SVLICxK.

HV-DP500LIC Licence for 512 data points. Requires HV-SVLICxK.

HV-DP1KLIC Licence for 1024 data points. Requires HV-SVLICxK.

HV-DP4KLIC Licence for 4096 data points. Requires HV-SVLICxK.

HV-DP10KLIC Licence for 10240 data points. Requires HV-SVLICxK.

CCTV LICENCES (Require HV-SVLICxK and HV-SVIDLIC)

HV-CAMLIC001 Licence for the connection to 1 Camera. Requires HV-SVLICxK and HV-SVIDLIC.

HV-CAMLIC016 Licence for the connection to 16 Cameras. Requires HV-SVLICxK and HV-SVIDLIC.

HV-CAMLIC036 Licence for the connection to 36 Cameras. Requires HV-SVLICxK and HV-SVIDLIC.

HV-CAMLIC064 Licence for the connection to 64 Cameras. Requires HV-SVLICxK and HV-SVIDLIC.

HV-CAMLIC128 Licence for the connection to 128 Cameras. Requires HV-SVLICxK and HV-SVIDLIC.

HV-CAMLIC256 Licence for the connection to 256 Cameras. Requires HV-SVLICxK and HV-SVIDLIC.

ACCESS CONTROL LICENCES (Require HV-SVLICxK and HV-SSVACLIC)

HV-ACD001 Single gate control licence. Requires HV-SVLICxK and HV-SVACLIC.

HV-ACD010 10 gate control licence. Requires HV-SVLICxK and HV-SVACLIC.

HV-ACD025 25 gate control licence. Requires HV-SVLICxK and HV-SVACLIC.

HV-ACD050 50 gate control licence. Requires HV-SVLICxK and HV-SVACLIC.

HV-ACD100 100 gate control licence. Requires HV-SVLICxK and HV-SVACLIC.

Fire & Safety



DCCTINE0FIRECOVER-600-20230331

