

# STI Euro Stopper®



## PRODUCT OVERVIEW

Protective cover helps prevent malicious or accidental false fire alarms. This newly styled protective cover further enhances the Stopper® range, which has helped to prevent false fire alarms around the world for decades, without restricting legitimate operation of devices such as fire alarm break glass call points. Sleeker and less intrusive in its design, this compact device incorporates the existing features of the Stopper but is now visibly smaller. The new hinge arrangement increases the durability, strength and quality of this essential protective cover. Ideal for schools, colleges, hospitals, nursing homes, hotels, factories, leisure centres and all public buildings where there is a history or a threat of false fire alarms or any unwanted activation of call points and switches.

## HOW IT WORKS

The Euro Stopper consists of a clear, tamperproof, tough polycarbonate cover and frame that retrofits over the break glass call point. When lifted to gain access to the break glass, its optional battery powered integral sounder emits an ear piercing 96 dB (at 1 metre). Immediate attention is drawn to the area and the prankster will either run or be caught.

## ABOUT THE *Glow Guide*

The Glow Guide is a unique material that is embedded in the perimeter of the frame and illuminates in the dark. It creates a radiant glow around the manual call point making it easier to locate in unlit areas. Glow Guide comes as standard with all models.

## KEY FEATURES

### General Information

- Protective cover helps prevent malicious or accidental activations of call points and switches.
- Three year guarantee against breakage of polycarbonate in normal use (one year on electromechanical and electronic components).

### Design

- Prevents false alarms and unwanted activation, without hindering legitimate operation of a manual call point in the event of an emergency.
- Glows in the dark.

### Construction

- Tough polycarbonate housing can withstand the severest of knocks.

### Installation

- A simple 4 fixing installation can retrofit over existing device.
- Can accommodate flush or surface mounted applications.
- Polycarbonate tested -40°C (-40°F) to 49°C (120°F).

### Electronics

- Available with or without a 96 dB integral sounder, powered by a 3V lithium battery.
- Optional 12-24 VDC powered units.

### Options

- One breakseal is supplied with each model. Additional breakseals are available for added security.
- Available in a range of colors.
- Custom labelling available.
- For Red and Green options, view Euro Stopper Multi Kit.

### Remote Wireless Monitoring of Call Points

- You can now be alerted to any vandalism or authorised use of a manual call point in the event of an emergency. Upon activation, the Euro Stopper (when fitted with an optional transmitter and sounder) will emit a localised alarm as well as triggering the 8-Channel Receiver (STI 34108), providing a visual and audible indication, remotely.



For more information, call 1-800-888-4784 (4STI) or visit [www.sti-usa.com](http://www.sti-usa.com)



**Safety Technology  
International, Inc.**

# STI Euro Stopper®

Dimensions and Technical Information

## BUILD YOUR OWN MODEL

STI-1 5 -

### Prefix:

5 = Euro Stopper

### Mounting Options:

0 = Flush Mount  
C = 32mm Surface Spacer  
D = 50mm Surface Spacer

### Sounder & Wireless Options:

10 = Label Hood without Sounder  
20 = Label Hood with Sounder  
30 = Label Hood with Sounder/Relay  
40 = Label Hood with Sounder/Wireless  
50 = Label Hood with Sounder/Wireless/Relay

### Color & Label Options:

#### No Label

NK = Black  
NB = Blue  
NG = Green  
NE = Orange  
NR = Red  
NW = White  
NY = Yellow

#### Custom Label\*

CK = Black\*  
CB = Blue\*  
NG = Green\*  
CE = Orange\*  
CR = Red\*  
CW = White\*  
CY = Yellow\*

\*Custom Label = Max. 2 lines, 20 characters per line including spaces

### Accessories:

**STI-6506** 32mm spacer (supplied with STI-15C10, STI-15C20, STI-15C30, STI-15C40 & STI-15C50)  
**STI-6507** 50mm spacer (supplied with STI-15D10, STI-15D20, STI-15D30, STI-15D40 & STI-15D50)  
**STI-6508** Backplate for Euro Stopper Series  
**STI/BS** Break seals (Pack of 10)  
**CKE-015-LIT** Sounder Cartridge  
**CKE-015** Sounder & Relay Cartridge  
**CKE-015-WIR** Sounder, Wireless & Relay Cartridge  
**E009** Servicing Pin

## EURO STOPPER MULTI KIT

For further Red & Green options, see Euro Stopper Multi Kit Literature.

The Euro Stopper Multi Kit comes in kit form allowing the user to assemble the product in the best way to suit their applications.

The Euro Stopper is supplied with red housing shell with operating instructions: 'IN CASE OF FIRE - LIFT COVER BREAK GLASS', and green housing shell with operating instruction 'IN CASE OF EMERGENCY - LIFT COVER BREAK GLASS TO OPEN DOOR'. Space above is available to affix a label, achieving dual language operating instructions. Multi-lingual labels are supplied as standard. All Euro Stopper Multi Kit frames come with Glow Guide as standard and one breakseal.

### Euro Stopper Multi Kit Product Codes:

**STI-15010ML** Euro Stopper Multi Kit - Flush Non Sounder  
**STI-15C10ML** Euro Stopper Multi Kit - Surface (32mm spacer) Non Sounder  
**STI-15D10ML** Euro Stopper Multi Kit - Surface (50mm spacer) Non Sounder  
**STI-15020ML** Euro Stopper Multi Kit - Flush with Sounder  
**STI-15C20ML** Euro Stopper Multi Kit - Surface (32mm spacer) with Sounder  
**STI-15C20ML** Euro Stopper Multi Kit - Surface (50mm spacer) with Sounder

For further information on the Euro Stopper Multi Kit please contact Sales.

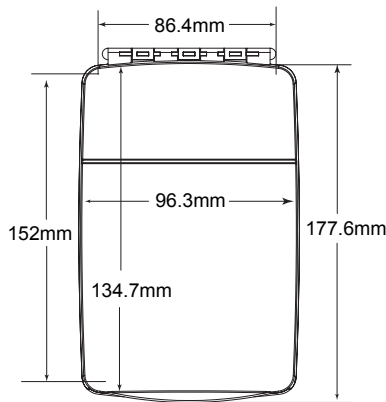

Flush Mount  
Front View

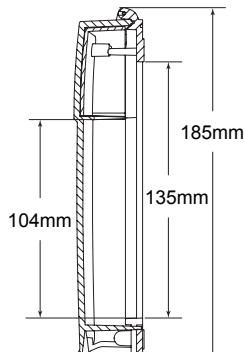

Flush Mount  
Side View

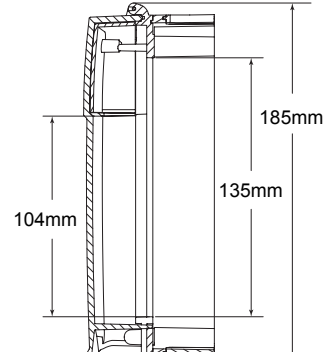

Surface Mount  
Side View (32mm Spacer)

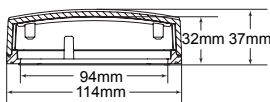

Flush Mount  
Top View

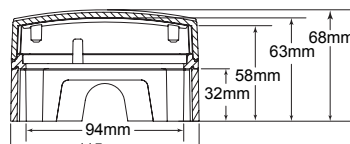

Top View (32mm Spacer)

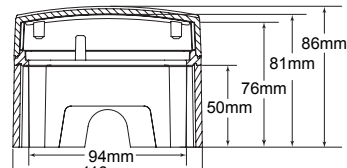

Top View (50mm Spacer)



**Safety Technology  
International**

2306 Airport Road  
Waterford, Michigan  
48327 - 1209

Tel: +248-673-9898  
Fax: +248-673-1246  
Toll-free: 0800-888-4STI  
info@sti-usa.com  
www.sti-usa.com

Taylor House  
34 Sherwood Road  
Bromsgrove  
Worcestershire  
B60 3DR, England

Tel: +44 (0)1527 520 999  
Fax: +44 (0)1527 501 999  
info@sti-emea.com  
www.sti-emea.com